

# User Manual

## K-BUS KNX Multifunctional Gateway\_V1.6

BTAI-06/05.1

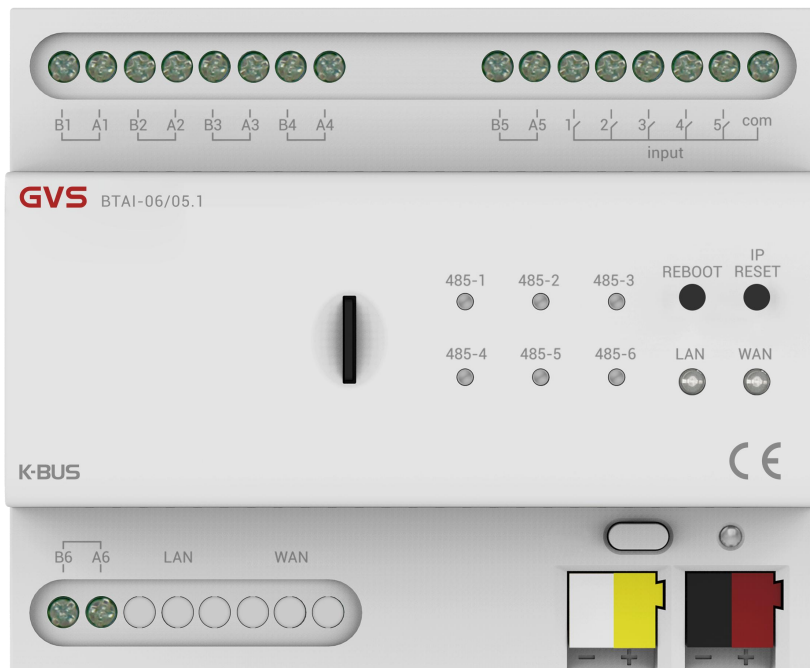

**KNX/EIB Home and Building Control System**

# Contents

Chapter 1 Summary .....	1
Chapter 2 Technical Data .....	3
Chapter 3 Dimension and Structural Diagram .....	5
3.1 Dimension Diagram .....	5
3.2 Structural Diagram .....	5
3.3 Connect Gateway to APP .....	6
3.3.1 Connect to GVS Smart Assistant APP .....	6
3.3.2 Connect to GVS Smart APP .....	7
Chapter 4 The utilization of Gateway, APPs and Management platform .....	8
Chapter 5 GVS Smart Assistant APP .....	10
5.1 Download and Install .....	10
5.2 Account and Login .....	10
5.3 Project management .....	12
5.3.1 Local project .....	12
5.3.2 Cloud project .....	14
5.3.3 Adding building .....	15
5.3.4 Building list .....	17
5.3.5 Building edit .....	18
5.3.6 Project Info edit .....	21
5.3.7 Import configuration .....	22
5.4 Building configuration .....	23
5.4.1 General setting .....	23
5.4.2 Add central control .....	26
5.4.3 Gateway General Function configuration .....	29
5.4.4 485 Library file configuration .....	30
5.4.5 Room Configuration .....	32
5.4.6 Device configuration .....	33
5.4.7 Scene configuration .....	38
5.4.8 Automation Scene Configuration .....	41
5.4.9 Download configuration .....	48
5.5 Gateway information .....	49

5.6 Network configuration .....	50
5.7 Import XML .....	51
5.8 Central log .....	54
5.9 Gateway OTA .....	55
5.10 Template Management .....	58
5.11 User Center .....	59
5.11.1 My Account management .....	60
5.11.2 Engineering personal management .....	61
5.11.3 Project Review .....	63
5.12 Device type .....	66
5.12.1 Switch .....	66
5.12.2 Brightness adjustment .....	67
5.12.3 Relative+Brightness adjustment .....	69
5.12.4 Colour temperature lamp .....	71
5.12.5 RGB .....	75
5.12.6 RGBW .....	77
5.12.7 RGBCW .....	80
5.12.8 Curtain position .....	86
5.12.9 Roller blind position .....	88
5.12.10 Venetian blind position and slat .....	90
5.12.11 Roller blind step/move .....	92
5.12.12 Curtain step/move .....	93
5.12.13 HVAC .....	95
5.12.14 Air conditioner .....	101
5.12.15 Floor heating .....	107
5.12.16 Central Ventilation system .....	110
5.12.17 Background music .....	120
5.12.18 Energy monitoring .....	127
5.12.19 AQI .....	129
5.12.20 PM2.5 .....	130
5.12.21 PM10 .....	131
5.12.22 Temperature sensor .....	132
5.12.23 Humidity sensor .....	134
5.12.24 CO2 sensor .....	135

5.12.25 CO sensor .....	136
5.12.26 Formaldehyde sensor .....	137
5.12.27 VOC sensor .....	139
5.12.28 Brightness sensor .....	140
5.12.29 Wind sensor .....	142
5.12.30 General IO Device .....	143
5.12.31 Fire alarm .....	145
5.12.32 Flood alarm .....	145
5.12.33 Gas alarm .....	145
5.12.34 Smoke alarm .....	145
5.12.35 Motion sensor .....	146
5.12.36 Fresh Air ventilator .....	147
5.12.37 Panasonic Fresh Air .....	150
5.12.38 Humidifier .....	152
5.12.39 Switch panel .....	155
5.12.40 Smart screen .....	157
5.12.41 Integrated environmental sensor .....	159
5.12.42 KNX AQI .....	160
5.12.43 KNX PM2.5 .....	161
5.12.44 KNX PM10 .....	162
5.12.45 KNX Temperature sensor .....	164
5.12.46 KNX Humidity sensor .....	166
5.12.47 KNX CO2 sensor .....	168
5.12.48 KNX CO sensor .....	169
5.12.49 KNX Formaldehyde sensor .....	170
5.12.50 KNX VOC sensor .....	172
5.12.51 KNX Brightness sensor .....	174
5.12.52 KNX Wind sensor .....	176
5.12.53 KNX TVOC sensor .....	177
5.12.54 Weather station .....	179
5.12.55 Legrand 13 screen .....	185
<b>Chapter 6 KNX Engineering Assistant Management Platform .....</b>	<b>187</b>
6.1 Summary .....	187
6.2 Enterprise Management Client .....	188

<b>6.2.1 Login .....</b>	<b>188</b>
<b>6.2.2 Home .....</b>	<b>189</b>
<b>6.2.3 Project management .....</b>	<b>190</b>
<b>6.2.4 Engineer management .....</b>	<b>196</b>
<b>6.2.5 Device management .....</b>	<b>202</b>
<b>6.2.6 Project template management .....</b>	<b>206</b>
<b>6.2.7 Delete record management .....</b>	<b>208</b>
<b>6.2.8 Feedback list .....</b>	<b>210</b>
<b>6.2.9 485 Protocol management .....</b>	<b>211</b>

## Chapter 1 Summary

KNX Multifunctional Gateway is a device that supports both remote control and LAN control. Users can easily utilize the "GVS Smart" app to control the gateway and its associated sub-devices, furthermore, the status of devices can be synchronized and displayed within the app. This gateway supports various device types, including KNX devices, RS485 devices, third-party TCP/IP protocol devices, and dry contact devices. Data configuration for the gateway can be done through the dedicated configuration app "GVS Smart Assistant" which allows for editing and writing configurations. Additionally, it is equipped with a KNX Engineering Assistant Management Platform to streamline the management of project information, gateway details, and configuration data in large-scale projects, thereby enhancing collaboration and debugging capabilities as well as comprehensive project management.

KNX Multifunctional Gateway is a modular installation device for fast installation in the distribution board on 35 mm mounting rails to DIN EN 60 715. The electrical connection is implemented by using screw terminals. The connection to the KNX bus is implemented using the supplied bus connection terminal, and connect to local router with LAN port, as well as need an extra voltage supply 9~36V DC. Communicate externally or within a local network through the WAN port. Ensure power is supplied only after connections are normal, prevent potential short circuits and damage to the equipment.

This manual provides detailed technical information about the KNX Multifunctional Gateway, including installation and programming details, and explains how to use it in the practical examples.

**This document only provides operational instructions for "GVS Smart Assistant" app and "KNX Engineering Assistant Management Platform". Details regarding the "GVS Smart" app are not illustrated here. Please refer to the relevant user manual "GVS\_GVS Smart App\_UM" for further information.**

The main functions are summarized as follows:

- Support KNX protocol
- Support 6 485 interfaces and 1 TCP/IP protocol communication interface
- Support the customization of 485 protocol via the web
- Communicate with sub devices through Gateway, to realize the control of KNX or "GVS Smart" APP to 485 devices
- Support multiple devices: Switch, Dimming, Curtain, Scene, Colour temperature, RGB, RGBW, RGBCW, RTC, AC, Ventilation system, Audio control, Ambient status, Sensor, weather station, Legrand 13 screen and so on
- Dry contact input detection: Dry contacts, sensors, fingerprint locks, etc
- Home management and remote control via "GVS Smart" APP
- Under the LAN, control device and scene via "GVS Smart" APP
- Execute local automation scenario
- Provide supporting "Smart Assistant" APP and KNX Engineering Assistant Management Platform, support multi-person collaboration
- Support remote configuration, OTA update

## Chapter 2 Technical Data

<b>Power Supply</b>	Bus voltage	21~30V DC , via the KNX bus
	Bus current	<5mA
	Bus consumption	<150mW
<b>Auxiliary Supply</b>	Voltage	9-36V DC
	Current	<98.5mA/24V; <80mA/30V
	Consumption	<2.4W
<b>Connections</b>	KNX	Bus connection terminal(Red/Black)
	Auxiliary supply	Bus connection terminal(Yellow/White)
	Input	5 folds, $\leq 10M$
	RS485	6 folds, Screw terminals, Torque 0.4N-m Wire Range 0.2-2.5mm <sup>2</sup>
	WAN/LAN	RJ45 socket for 10/100 Mbps
<b>Operation and display</b>	WAN/LAN LED	Yellow LED flashing, network is connected
		Green LED flashing, communicates with network
	KNX LED	Green LED flashing, KNX running normally Red LED on, is meaningless
	RS485 LED	Yellow LED on, device running normally Yellow flashing, communicates with RS485
	Reboot button	Long press 10s to reboot system, all RS485 LEDs flashing 5 times
	IP Reset button	Long press 10s to reset IP address, all RE485 LEDs flashing slowly 5 times

<b>Temperature</b>	Operation	- 5 °C ... 45 °C
	Storage	- 25 °C ... 55 °C
	Transport	- 25 °C ... 70 °C
<b>Ambient</b>	Humidity	<93%, except dewing
<b>Dimension</b>	108 × 90 × 64mm	
<b>Mounting</b>	Standard 35mm DIN rail installation	
<b>Weight</b>	0.26kg	

## Chapter 3 Dimension and Structural Diagram

### 3.1 Dimension Diagram

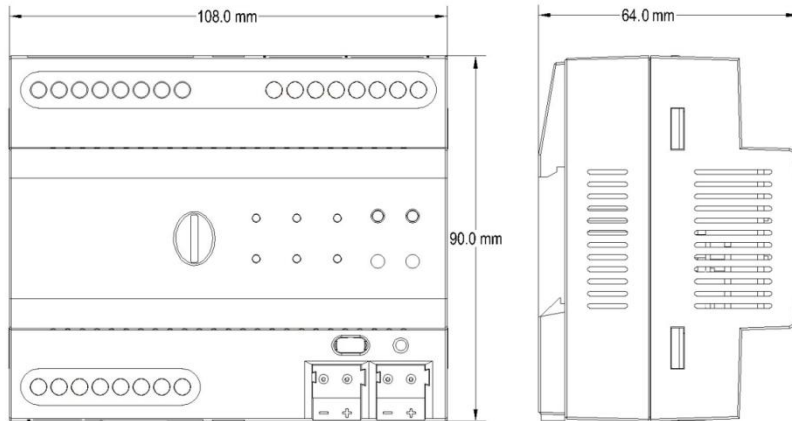

### 3.2 Structural Diagram

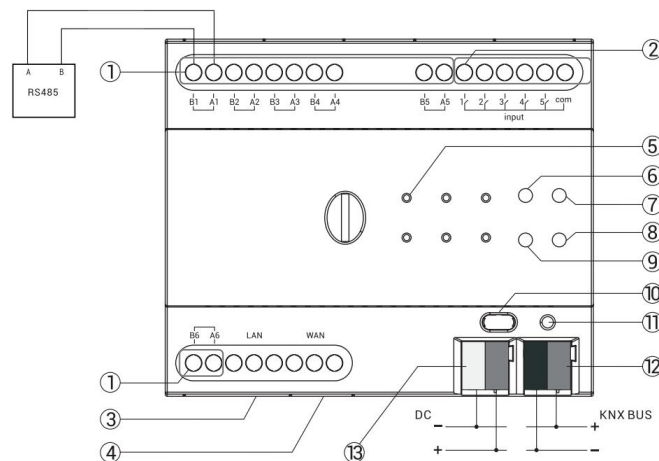

- ① RS485 connection terminals, 6 folds in all, include A, B
- ② Input terminals
- ③ LAN socket
- ④ WAN socket
- ⑤ RS485 LEDs
- ⑥ Reboot button
- ⑦ IP Reset button
- ⑧ WAN LED
- ⑨ LAN LED
- ⑩ Reserved button, not available
- ⑪ KNX LED
- ⑫ KNX bus connection terminal
- ⑬ Auxiliary supply connection terminal

Restore factory settings: press and hold button ⑥ and ⑦ at the same time for 10s, all RS485 LEDs will flash 5 times in a clockwise cycle, then the gateway will clear all the configurations and restore the factory default status.

### 3.3 Connect Gateway to APP

Procedure of connecting the gateway to "GVS Smart Assistant" and "GVS Smart" apps is explained as follow. And the operation and LED display of gateway please refer to the previous chapter.

**Note:**

**When connecting to the "GVS Smart Assistant," ensure that the mobile phone and gateway are in the same network.**

**Supports simultaneous connecting to "GVS Smart Assistant" and "GVS Smart".**

#### 3.3.1 Connect to GVS Smart Assistant APP

1.The gateway is working normally and is not connected to GVS Smart Assistant APP:

Upon power on, the gateway will broadcast by default, you can search and connect to it in APP. During this process, there is no any LED indications of the device.

Once a connection is established, pressing the reboot button (Button ⑥) twice within 3 seconds, to delete the connection with the "GVS Smart Assistant" and rebroadcasting. This action is effective whether or not a connection is already established. Simultaneously, all the RS485 LEDs will light up cyclically from right to left for 2min. During this time, you can search for and connect to the gateway again in APP.

If the connection is successful, stop broadcasting and LEDs flashing, establish a continuous heartbeat connection with the device. Once disconnection, broadcasting automatically resumes, allowing for re-connection with APP.

If the connection fail or timeout (failure to connect within 2 minutes), the LEDs will stop flashing, but still broadcasting.

2.The gateway is working normally and was connected to GVS Smart Assistant APP:

Upon power on, the gateway will broadcast by default, you can search and connect to it in APP.

During this process, there is no any LEDs indications of the device.

If the connection is successful, stop LEDs flashing, establish a continuous heartbeat connection with the device. Once disconnection, broadcasting automatically resumes, allowing for re-connection with APP. Stop broadcast only when reconnect to the APP.

### **3.3.2 Connect to GVS Smart APP**

Upon power on, the gateway will broadcast by default, you can search and connect to it in APP.

During this process, there is no any LED indications of the device.

Once a connection is established, pressing the IP Reset button (Button ⑦) twice within 3 seconds, to delete the connection with the "GVS Smart" and revert gateway to initial configuration, as well as rebroadcasting. Simultaneously, all the RS485 LEDs will light up cyclically from left to right for 2min. During this time, you can search for and connect to the gateway again in APP.

If the connection is successful, stop broadcasting and LEDs flashing.

If the connection fail or timeout (failure to connect within 2 minutes), the LEDs will stop flashing, but still broadcasting.

While during the flashing process, press the button twice again to repeat the above operation.

**Chapter 4 The utilization of Gateway, APPs and Management platform**

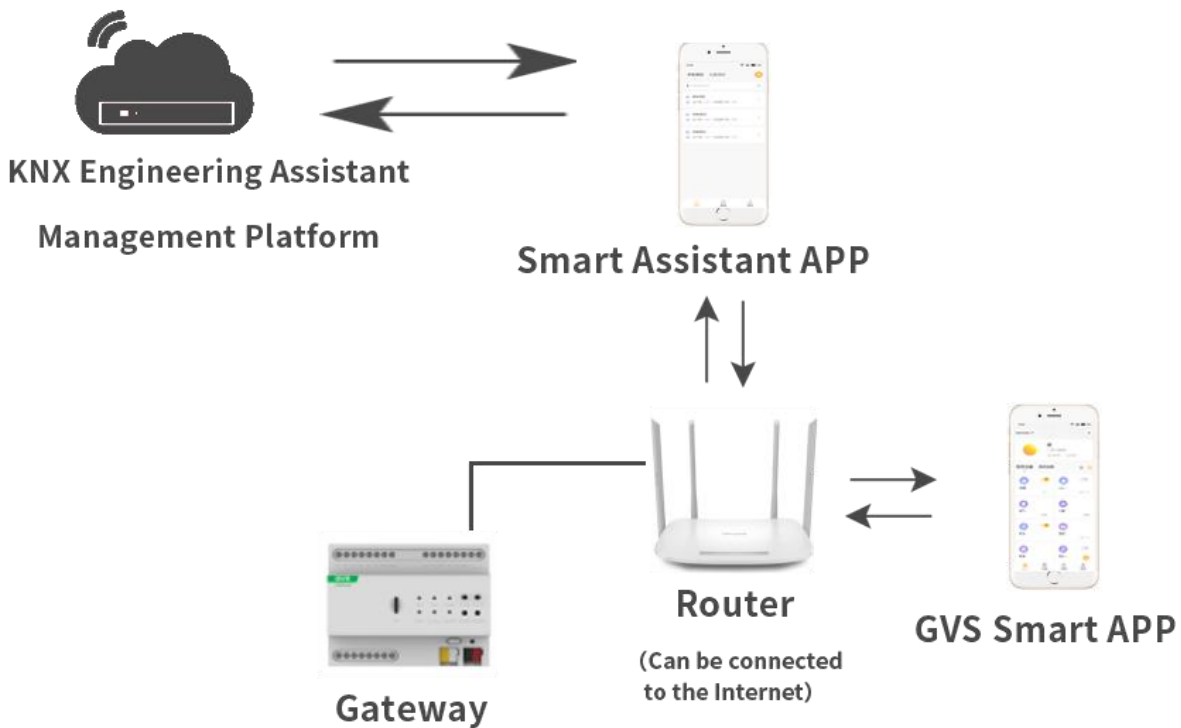

1. **GVS Smart Assistant APP** serves as a debugging tool for engineer, enabling the configuration of projects and engineering tasks. It facilitates the writing of configuration details to the gateway, including aspects such as rooms, devices, scenes, automation, and more. Additionally, it supports the reading of gateway-related information for display and analysis purposes. Furthermore, it allows for the uploading of configured project files to the KNX Engineering Assistant Platform, facilitating remote configuration and collaborative efforts.

2. **KNX Engineering Assistant KNX Management Platform** complements the cloud management platform of the "GVS Smart Assistant". It manages all submitted configuration files in the form of projects and buildings, streamlining the complexity of engineering management. Additionally, it provides a 485 protocol configuration page for customizing 485 protocol interface files.

3. **Gateway** serves as the central component of the system. It receives and stores configuration information transmitted by GVS Smart Assistant APP, while also establishing a cloud connection with GVS Smart APP. Through this connection, the gateway forms bonding relationships with homes, synchronizing all gateway data. This enables the control of sub devices through the gateway.

4. **GVS Smart APP** is a mobile APP for end-user to control and manage smart devices. You can bind smart devices with the APP, and manage aspects such as home settings, devices, rooms, and members.

## Chapter 5 GVS Smart Assistant APP

### 5.1 Download and Install

Please Download the “GVS Smart Assistant” APP from Google Play.

### 5.2 Account and Login

The account for GVS Smart Assistant APP requires created in KNX Engineering Assistant KNX Management Platform, and it cannot registered in APP. Please following these steps:

1. Apply an account of KNX Engineering Assistant Management Platform: contact the System Administrator (normally is the manufacturer or organization) to create a new Corporate Administrator role in the platform. Upon successful creation, account and password are automatically generated.

2. Create member accounts: contact the role of Corporate Administrator or Project Manager to create a new member. Upon successful creation, account and password for the Platform and APP are automatically generated. This account is linked to unique mobile number ([non-repetitive in the same corporation](#)).

3. Login: use the account and password from the previous step to log into GVS Smart Assistant APP. Alternatively, login can be accomplished via mobile number and message verification.

User Login is as follows:

The image displays two side-by-side screenshots of the GVS Smart Assistant APP login interface. Both screens show a 'Welcome' message and the instruction 'Login with password or verification code'. The left screenshot is for 'Verification Code Login', featuring a field for a mobile phone number (prefixed with '+86') and a field for a verification code. The right screenshot is for 'Username Login', featuring fields for 'Enterprise name', 'Username', and 'Password'. Both screens include a 'LOGIN' button and an 'Automatic next login' checkbox.

Note: the login password for both the platform and APP are shared. Password modification is not supported on the APP. If password modification is necessary, please contact the platform administrator for a password reset. Accounts are centrally managed through the platform; if an account is deleted, access will no longer be allowed.

### Role Permissions

In GVS Smart Assistant APP, different account roles have varying operational permissions, Project Manager > Engineer.

**Project Manager:** possesses the highest level of authority, enabling the creation, management, and download of all cloud projects. They can review and edit project information, authorize project members, and conduct project audit. Additionally, they can manage members, including the ability to add and remove members.

**Engineer:** holds the sub level of authority and can access the APP to download and configure authorized projects/examples. They can create buildings for projects, link gateways, add devices, rooms, scenes, automation, and conduct testing and debugging on configured residences. Engineers can upload and download configuration files and submit them for review.

## 5.3 Project management

Select "Projects" to enter the project management interface, which contains both local and cloud projects. Local projects refer to projects created locally or downloaded from the cloud, while cloud projects are those already uploaded to the management platform. Cloud projects can be downloaded for local editing, and local projects can be uploaded to the cloud.

Different account roles have different permissions for project management:

Project Manager can create new local projects and upload them to the cloud. They can view all cloud projects, download, edit them in APP, and re-upload them to the cloud. Additionally, they can delete cloud projects in APP, with those changes syncing to the management platform.

Engineers cannot create local projects but can view authorized cloud projects, download, edit them in APP, and upload them back to the cloud.

Within projects, buildings are categorized as local files or cloud files. Local files are those downloaded or created locally, while cloud files are those already uploaded.

### 5.3.1 Local project

Local projects serve for users to configure and edit, where all configurations must be edited, connected to device, and tested locally on the APP before being uploaded to the cloud. Local projects can be obtained through the following two methods:

(1)By clicking the icon "+" at the top right corner of the project management interface, a creation window will pop up. Here, input the name of the new project (names within the same enterprise must be unique) and its address. Upon confirmation, the new project is established. Once completion, the new project will be visible in "Local Project" and synchronously uploaded to "Cloud Project", as shown in the following figures.

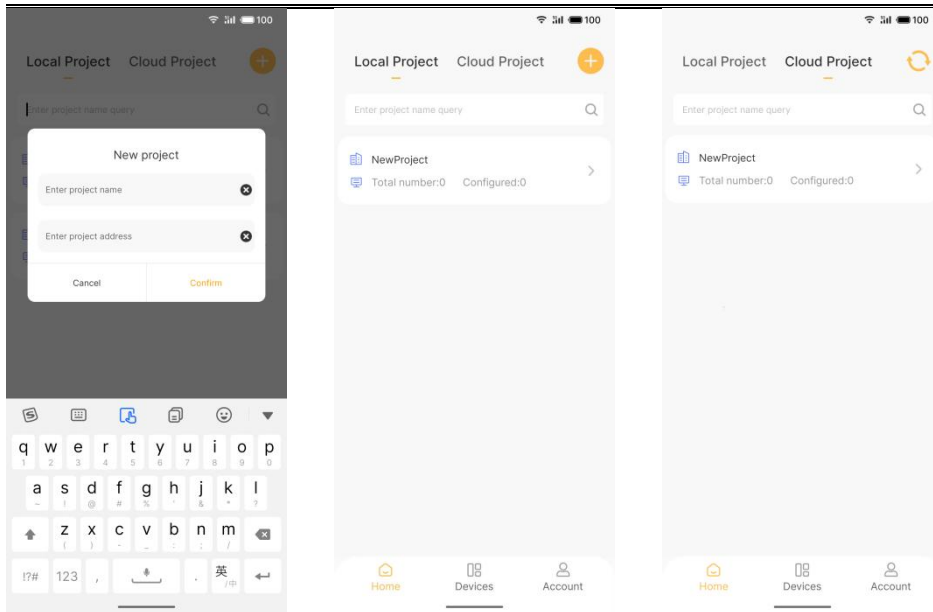

(2)Download the desired projects or building files from "Cloud Project", corresponding project information can also be viewed in the local project list. For details on how to obtain these, please refer to the next section.

The project list showcases the project name, total number of buildings, and the number of already configured. You can search for projects by entering the project name in the search bar:



1)Total Number: indicates the number of buildings established in the project. If there are no buildings in the project yet, it will display as 0.

2)Configured : indicates the number of building configuration files which is sent to the gateway in the project. If no configuration files have not been sent, it will display as 0.

Note: The APP does not support modifying project names, addresses, or deleting projects. If any editing is needed, please carry out these actions using the KNX Engineering Assistant KNX Management Platform.

### 5.3.2 Cloud project

Select "Cloud project" to view the project names, total number of buildings, and the number of configured building files of cloud projects. By clicking the icon  at the top right corner or drop down list, synchronize the latest cloud projects and their configuration files. Input the project name in the search bar allows for project searches.

Choose a cloud project to check the status of build configuration files. Each column displays the status of the configuration files on the upper right-hand side and their download status below, icon . Indicates files not yet downloaded to local. By clicking the icon  at the top right corner of the interface and selecting "Edit Housing" to enter edit mode. Then you can batch download or delete the configuration files from the cloud project.

Choosing "Sync Cloud" to synchronize the latest building list for the project on the cloud. Swipe left to display the "Delete" option, upon clicking and confirming, a building can be deleted. **Note:** Deleting a cloud project locally will synchronize this action with the management platform.

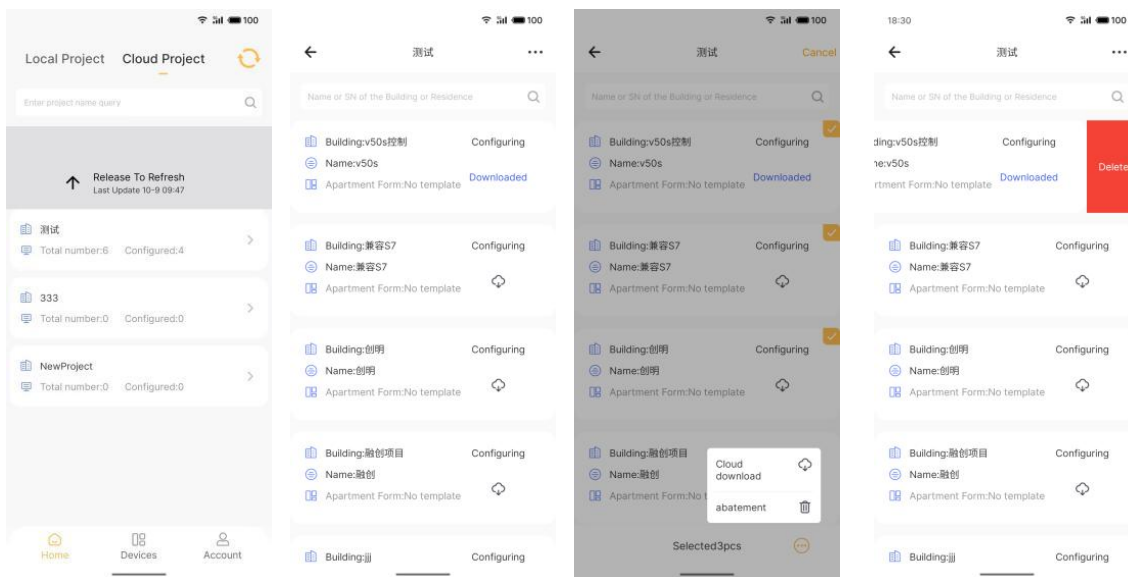

### 5.3.3 Adding building

Within the local projects, selecting "Local Files" to create new buildings and then clicking on the icon  at the top right corner of the interface. Choose "Add Housing" to navigate to the information setting interface for adding. The procedure is as follows:

(1) Create a new building, and set its address (requiring location authorization), name, unit name and room name. Upon confirmation, the building will be created, and return back to the building list page.

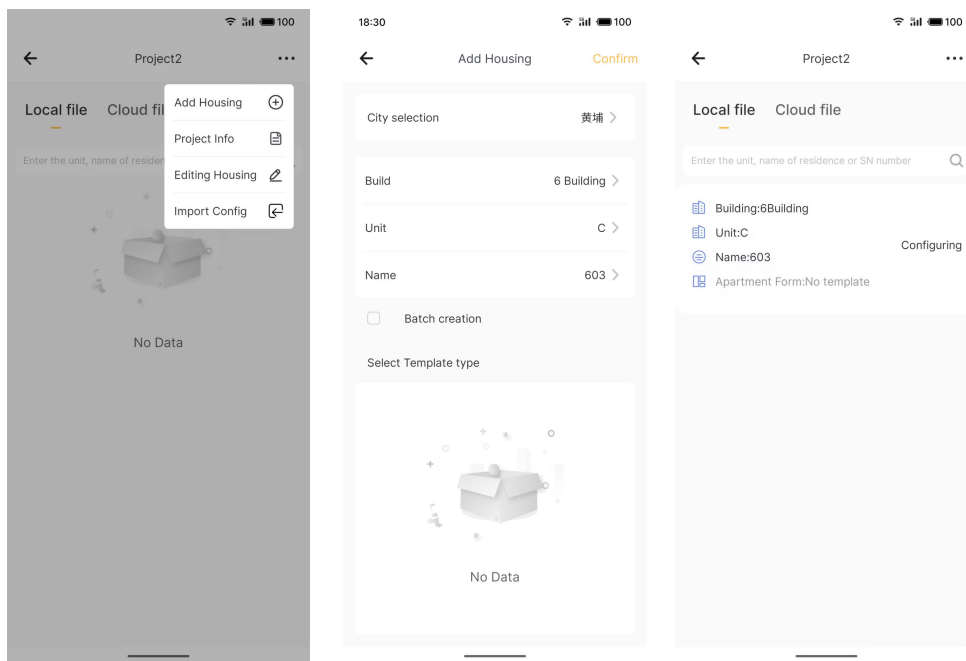

(2) Enable "Batch Creation" on the page and set the building address, building name, unit name, the number of rooms and the starting number of rooms, the maximum number of rooms can be created in batches at a time is 999.

The copied room names will have serial numbers added to the "starting number", for example, if the starting number is 601, the default is 601, 602, 603...

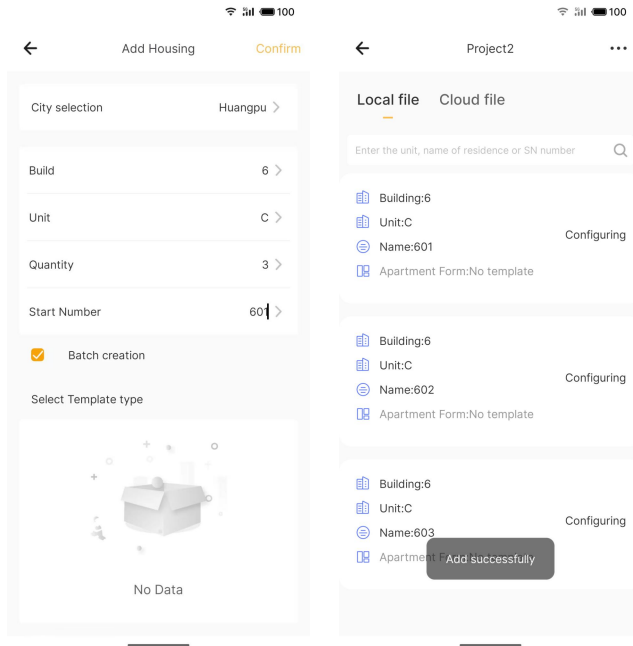

(3)Use template after setting the building address, building name, and room name.

The new building will directly adopt the template's 485 database file configuration, room configuration, device configuration, scene configuration, and automation scene configuration.

The used template name will be display on the building list.

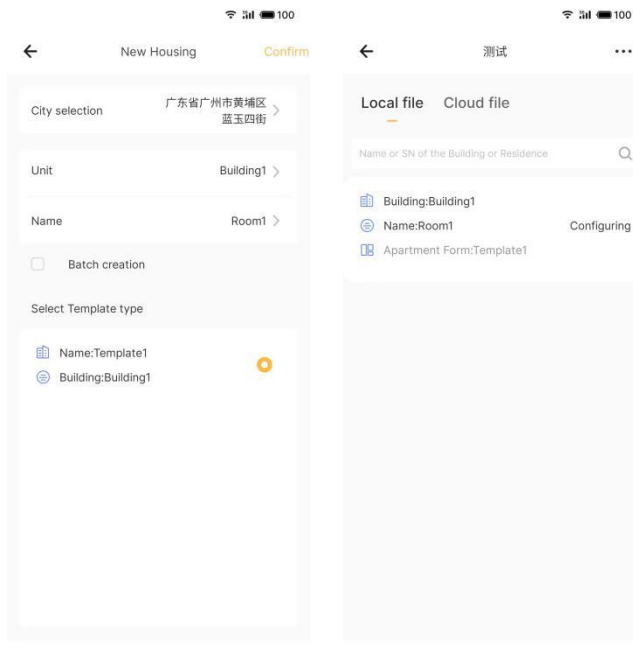

### 5.3.4 Building list

Once complete the building creation, you can view its information in "Local Files", which includes the building name, room name, the used template, and the file status (e.g., Configuring, To be reviewed, Audited). Input the building name, room name, or the gateway's SN number in the search bar, you can swiftly search for the building.

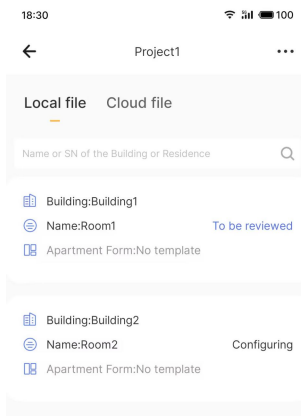

### Status of Building files

**Configuring:** still configuring the file and not submitted for review.

**To be reviewed:** upon submission for review, the status appears as "To be reviewed". In this case, the files should be audited by the Project Manager's account. During the reviewing, the new configuration file do not allow for uploading to the cloud, but it still can be delivered to the device.

**Audited:** after approval by the project manager, the file's cloud status changes to "Audited". Files in the status are considered completed and do not allow for uploading the new configuration file to the cloud, but it still can be delivered to the device.

**Note:** the "Audited" files can be restored for editing, and updating the local status from cloud to "Configuring".

### 5.3.5 Building edit

In the local building list, click on the icon "..." in the upper right corner of the interface, select "Editing Housing", to enter edit mode. While in edit mode, clicking on "Cancel" in the upper right corner will exit the editing mode.

During editing, you can select multiple buildings for batch operations (Upload to the cloud, Move home, and Abatement):

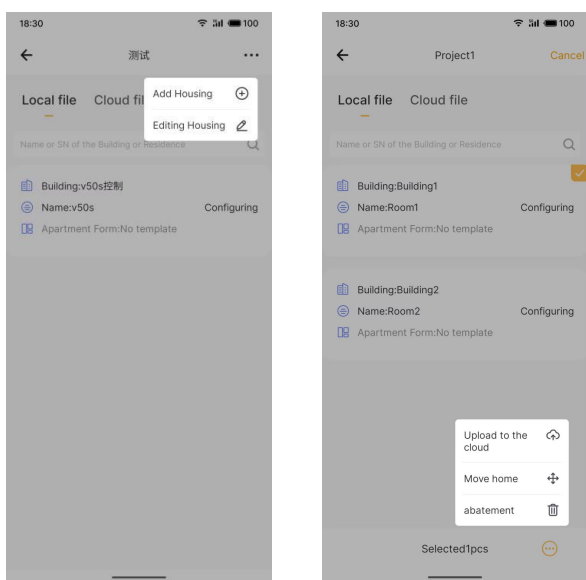

**【Upload to the cloud】** : Clicking this will prompt a window to enter upload description content. After inputting the content, confirm to upload.

The following situations prohibit uploading, and upon operation, a prompt will indicate a failed upload and the reason:

- 1)The building is not connected to the gateway.
- 2)The building is to be reviewed or has already been audited.

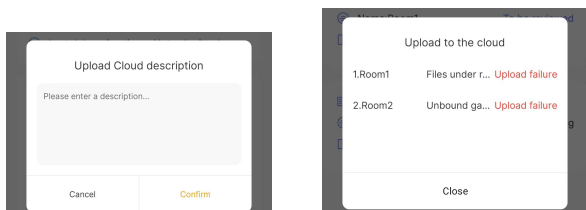

The upload operations should be performed after setting up the configuration file.

After uploading successfully, the file will be stored in the cloud, and you can also view and download it in the Cloud File of Local Project.

**【Move home】** : After clicking **【Move home】** , the following window will pop up. First, select the other project to which you need to move, then confirm the deletion to proceed with the migration. When performing the operation, the building under the current project will be deleted, and a new building will be created under the target project. If the building has been uploaded to the cloud, the cloud files will also be synchronized and moved after the operation, visible after refreshing the synchronization.

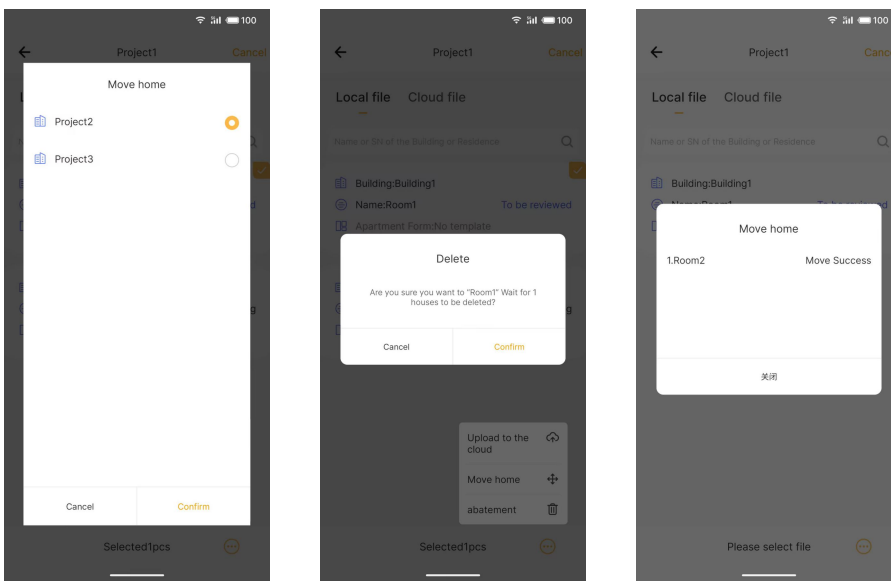

**【Abatement】** : After clicking **【Abatement】** , the following window will pop up. Confirm and the deletion

will be completed. A prompt will appear indicating that the deletion is successful.

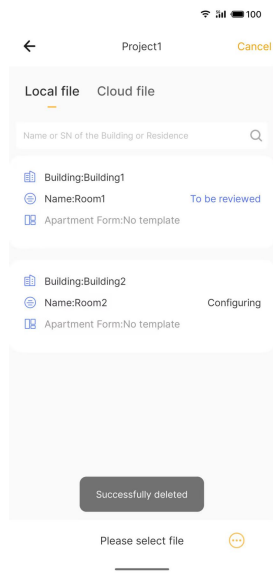
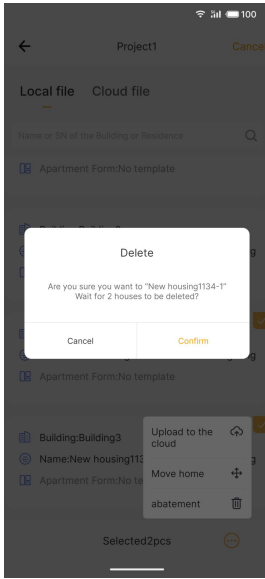

### 5.3.6 Project Info edit

Within the list of local files, clicking on the icon **⋮** at the top right corner of the interface, then select "Project Info" to edit the project name , address and time zone.

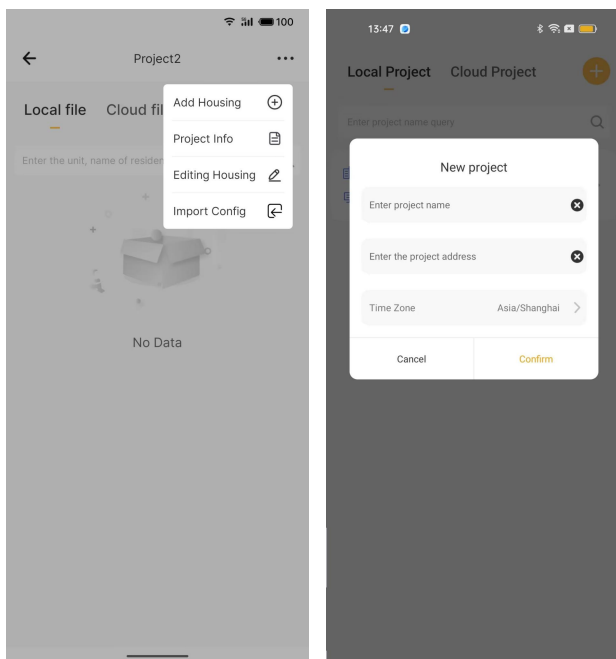

### 5.3.7 Import configuration

Within the list of local files, clicking on the icon **☰** at the top right corner of the interface, then select "Import config" to import local files (format .json). After the import is successful, you can see a new building file in the list. It directly applies all the configuration information of the imported file, including 485 library file configuration, Room configuration, Device configuration, scene configuration and Automation configuration and so on.

Within the general setting interface of building, click on the icon **☰** in the upper right corner to select "Export Config" to export file (format .json) to the local.

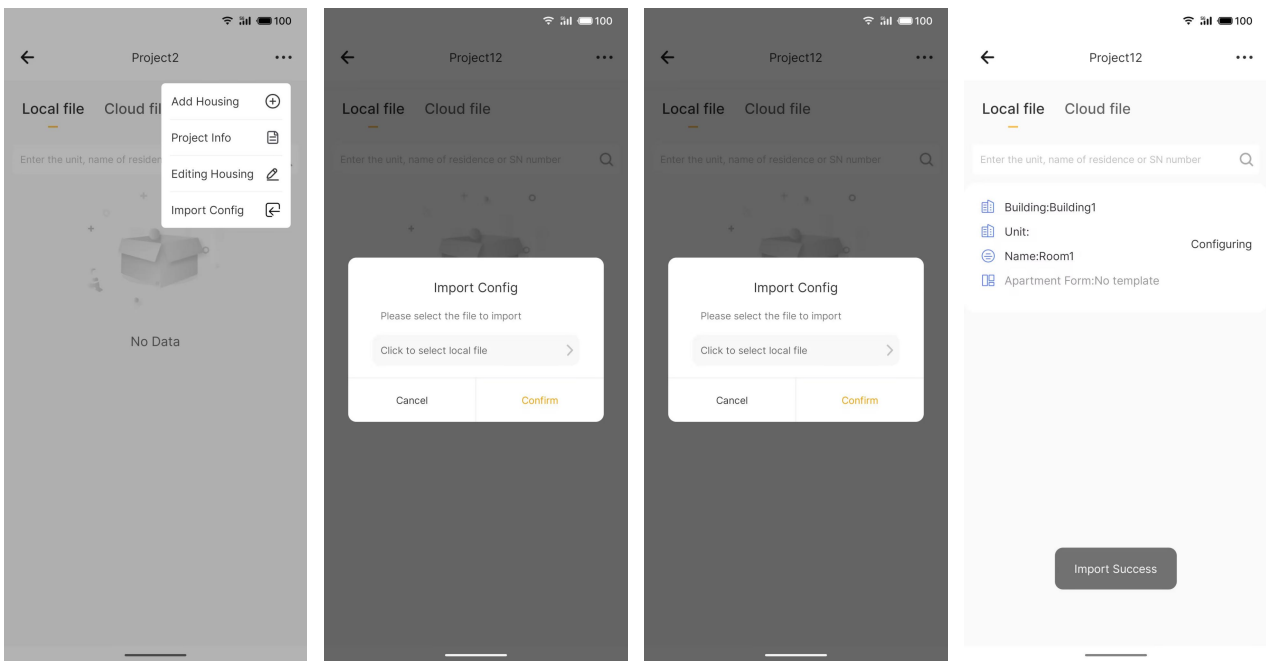

## 5.4 Building configuration

After establishing the project and buildings, you can set up configuration files for the buildings. The relevant operations are detailed below.

### 5.4.1 General setting

Access the building file configuration page, as shown below:

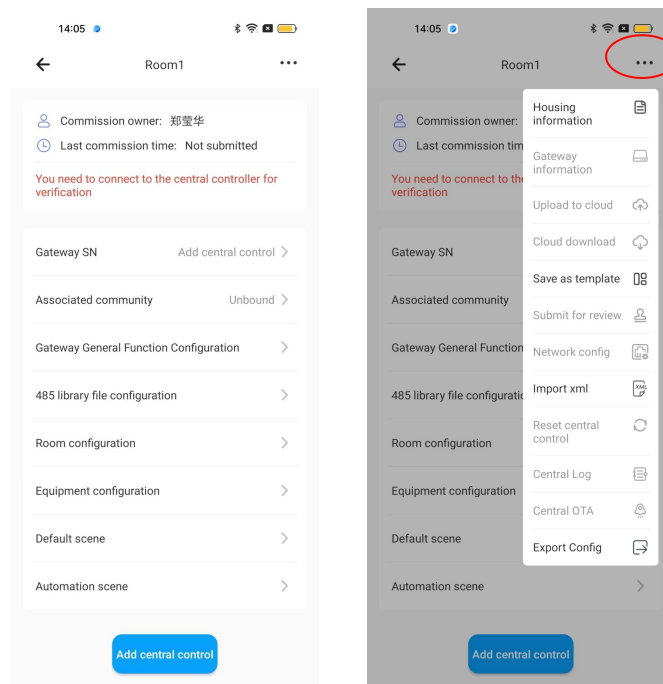

**【Commission owner】** : the person who created the configuration file, display user name “+” mobile phone number. If the file is downloaded from the cloud, the default information of the one who submitted the last time to the cloud is displayed. However, if the configuration information is modified and sent again, it will be updated to the current owner's information.

**【Last commission time】** : display the last debugging time after the configuration file was sent. If it has not been sent, it will display "Not submitted".

**【Gateway SN】** : when the gateway is not connected, it will display **【Add central control】** and the prompt "You need to connect to the central controller for verification" will be displayed above. Click to search for the gateway. If the gateway is connected, the connection status and the gateway SN code

will be displayed on the right. For more detailed operations, please refer to [Chapter 5.4.2](#).

**【Associated community】** : Click to scan the community QR code to bound the community.

Note: Please place the community QR code code in the scanning box. Please ensure that the system time of your device matches the time of the Vision and Sound GVS Smart assistant.

**【Gateway General Function Configuration】** : click to enter the gateway general function configuration interface, set the KNX physical address, synchronize time and date from KNX bus, etc. For detailed operations, please refer to [Chapter 5.4.3](#).

**【485 library file configuration】** : click to enter the 485 library file configuration interface, which displays the number of configured 485 library files. Maximum 6 files can be configured. For detailed operations, please refer to [Chapter 5.4.4](#).

**【Room configuration】** : display the number of configured rooms. Click to enter the room configuration interface. For detailed operations, please refer to [Chapter 5.4.5](#).

**【Equipment configuration】** : display the number of configured equipment. Click to enter the equipment configuration interface. For detailed operations, please refer to [Chapter 5.4.6](#).

**【Default scene】** : display the number of configured scenes. Click to enter the scene configuration interface. For detailed operations, please refer to [Chapter 5.4.7](#).

**【Automation scene】** : Displays the number of configured automation scenes. Click to enter the automation configuration interface. For detailed operations, please refer to [Chapter 5.4.8](#).

**【Add central control】 / 【Send config File】** : when the gateway is not connected, display **【Add central control**, click it to search for the gateway. For more details, please refer to [Chapter 5.4.2](#); when the gateway is connected, display **【Send config File】** . After confirming that all configurations have been completed, click it to send the configuration to the gateway. If the gateway is disconnected, the operation cannot be performed. For more details, please refer to [Chapter 5.4.9](#).

Click on the icon  in the upper right corner of the setting interface to access additional options as outlined below:

【Housing information】 : click to view/edit/delete building information, including building name, dwelling name, and address. Choosing deletion will remove all configurations associated with that building.

【Gateway information】 : it can only be operated after connecting to a gateway. Click to view/edit gateway information. For detailed operations, refer to [Chapter 5.5](#).

【Upload to cloud】 : it can only be operated after connecting to a gateway. Click to upload the configuration file to the cloud. [If previously uploaded, it will overwrite the existing cloud configuration file to ensure uniqueness.](#) Once uploaded, others can download the latest file from different locations.

Note: After uploading the new configuration file, if the gateway is online, the background will automatically push the latest configuration file to the gateway.

【Cloud download】 : click to download the latest configuration file from the cloud. [Downloading a file from the cloud will overwrite the local configuration of the building. Proceed with caution.](#)

【Save as template】 : click to save the configuration file as a template in the cloud for future use.

【Submit for review】 : it can only be operated after connecting to a gateway. Click to submit the configuration file for review. Post-submission, corporate administrator or project managers can review the file under APP account, or via the KNX engineering management platform.

【Network config】 : it can only be operated after connecting to a gateway. Click to view/set LAN port IP and WAN port IP settings. Refer to details in [Chapter 5.6](#).

【Import xml】 : Click to view/set XML files. Refer to details in [Chapter 5.7](#).

【Reset central control】 : it can only be operated after connecting to a gateway. Confirm then clear the gateway's configuration file.

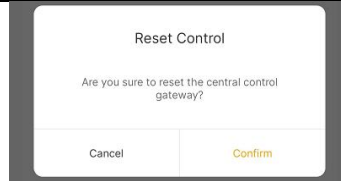

【Central Log】 : it can only be operated after connecting to a gateway. Click to view the central log list and refer to details in [Chapter 5.8](#).

【Central OTA】 : it can only be operated after connecting to a gateway. Click to the gateway OTA update, details please refer to [Chapter 5.9](#).

【Export Config】 : click to export the building's configuration(.json) to local file, please select the path to be stored when saving.

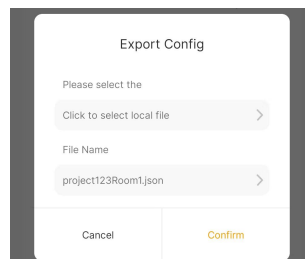

## 5.4.2 Add central control

Click the button 【Add central control】 to access the device search page, select the desired device for addition.

Alternatively, you can click on icon  in the top right corner of the page to directly scan the QR code on the device for addition.

Before adding the gateway device, please ensure the following settings are in place, as failure to do so may result in the device not being detected:

1. Please ensure that the WiFi of the mobile phone and the device are in the same LAN;
2. Ensure that the device is connected to the Internet;
3. Check whether the device is in the distribution mode.

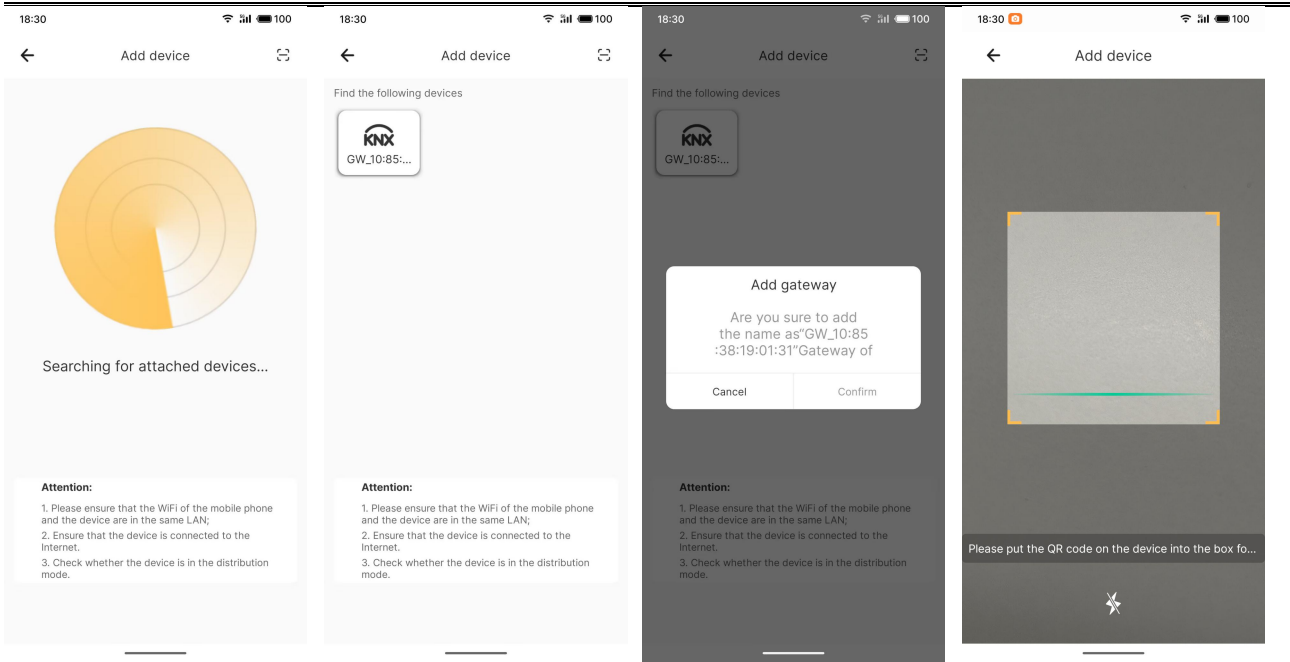

Once the gateway is connected, the information will be in the settings interface, including the gateway's connection status, SN code, and connection status. The following explains the various connection statuses:

**【Connected】** : the gateway is successfully connected to APP.



**【Connecting】** : each time if exit the settings page and return, it will automatically search for devices within the local network (automatic search is not enabled by default if the gateway hasn't been connected before or there is no WiFi connection), with the process displaying "Connecting".

If the device is found, it will establish a connection with the device, achieve device information, and verify its consistency with the current device. If multiple gateways are found, they will be verified sequentially until matching the current bound gateway and establishing connection directly.

If no matching the current bound gateway, a prompt will ask, "Discover a new gateway device and check whether the connection needs to be established?" If select "to connect", you can select a new gateway to connect to.



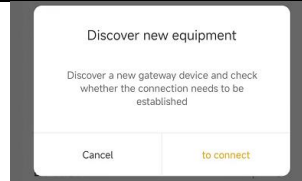

**【Not connected】** : if a period of time passes without successfully connecting to the gateway, the status will display as "Not Connected".



### 5.4.3 Gateway General Function configuration

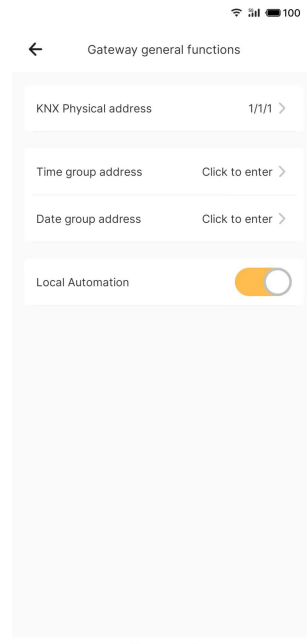

【KNX Physical address】 : it can only be operated after connecting to the gateway. Enter the KNX physical address, ranging from 0-15.0-15.1-255 (for example, 15.15.250). If the entered physical address is incorrect, it will prompt "Physical address is incorrect, please modify it".

【Time group address】 : 3byte type, Input group address to modify time via KNX bus. The address range is from 0-31/0-7/0-255 (for example, 1/1/1). If the entered physical address is incorrect, it will prompt "The group address is incorrect, please modify it".

【Date group address】 : 3byte type, Input group address to modify date via KNX bus. The address range is from 0-31/0-7/0-255 (for example, 1/1/1). If the entered physical address is incorrect, it will prompt "The group address is incorrect, please modify it".

【Local Automation】 : if activate the button , the automation scenes can be running in local; if deactivated , they remain inactive.

---

#### 5.4.4 485 Library file configuration

Click the button **【485 Library file configuration】** to access the setting page. The 485-1 to 485-6 correspond to the six RS485 interfaces on the KNX Multifunction Gateway (refer to the chapter [Structural Diagram](#) for details).

##### (1)Set 485 Library file

Each 485 interface can only be configured with one 485 library file. Click on the desired 485 interface to enter the file selection page, then choose a 485 library file, then click on the right side **↻ Select Version** to select a version, then confirm to complete the configuration. Utilize the search bar to swiftly locate a 485 library file by brand, model, name, or physical model.

Ensure to select the appropriate 485 library file based on the actual device configuration. Choosing an incorrect file will impede the device's functionality.

If the version of the selected 485 library file is not the latest, it will be displayed in red font in the configuration list, that is the file has a new version, please reconfigure.

If the desired device is not present in the existing list, manually create and configure it in the KNX Engineering Assistant Management Platform (485 Protocol Management).

For specialized needs beyond the configuration tool, please reach out to us for assistance.

##### (2)Edit 485 Library file

Return to the file selection page to select another 485 library file. Upon confirmation, the library file for that 485 interface will be modified, affecting all existing 485 configurations that have been associated with that interface. Then complete the modification.

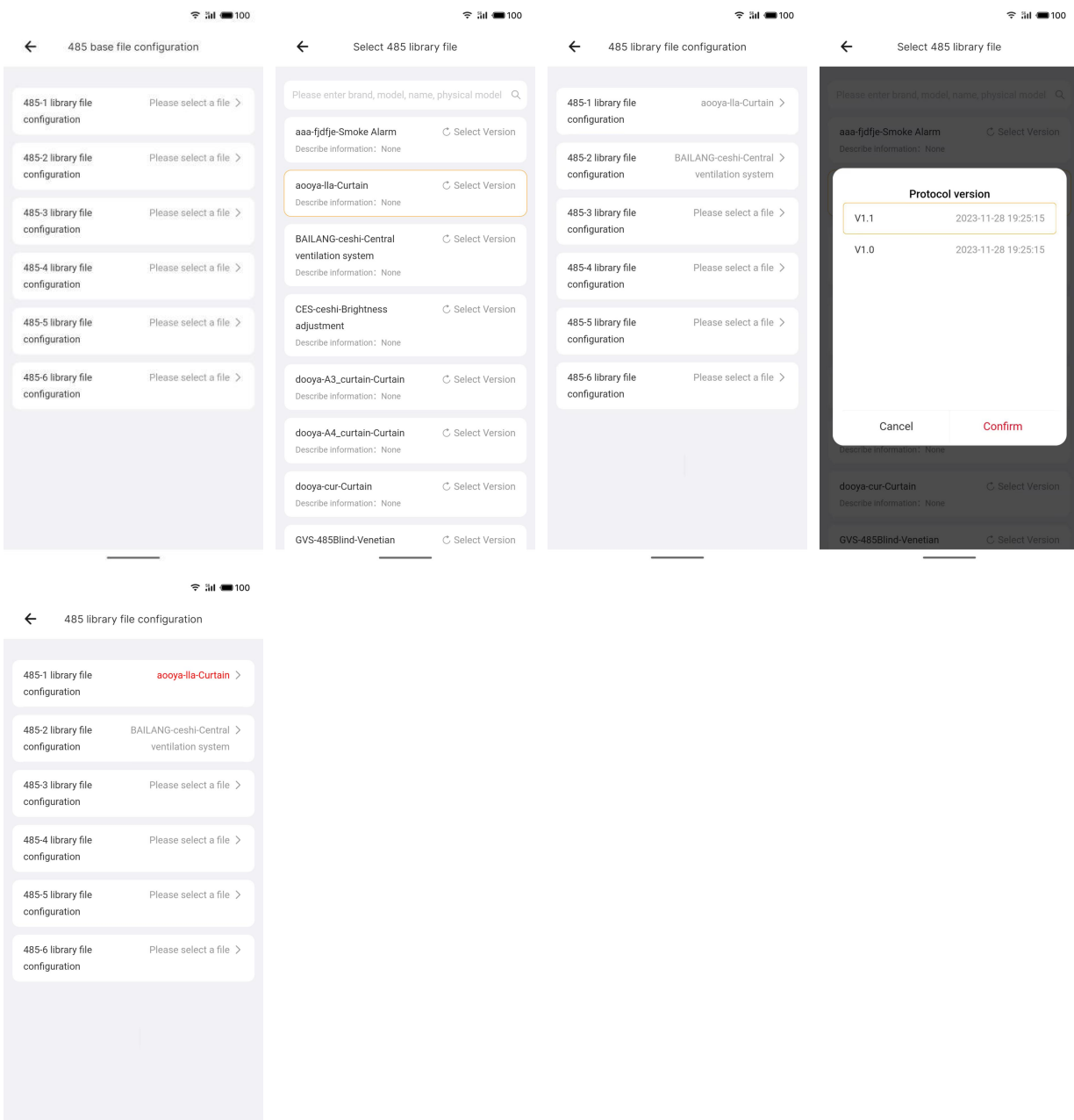



### 5.4.5 Room Configuration

Enter Room Configuration page, and you can add and manage rooms on this page.

#### (1)Add Room

Click "Add Room" to add a new room, input room's name description and confirm to complete adding. **Note: the description can not be empty and not repeat, or will add failure.**

#### (2)Edit/Delete Rooms

Swiping left an item of room list to edit  or delete rooms . **Note: the name description can not repeat. If there is a device connected with the room, and the deletion will not effect the device's other configuration.**

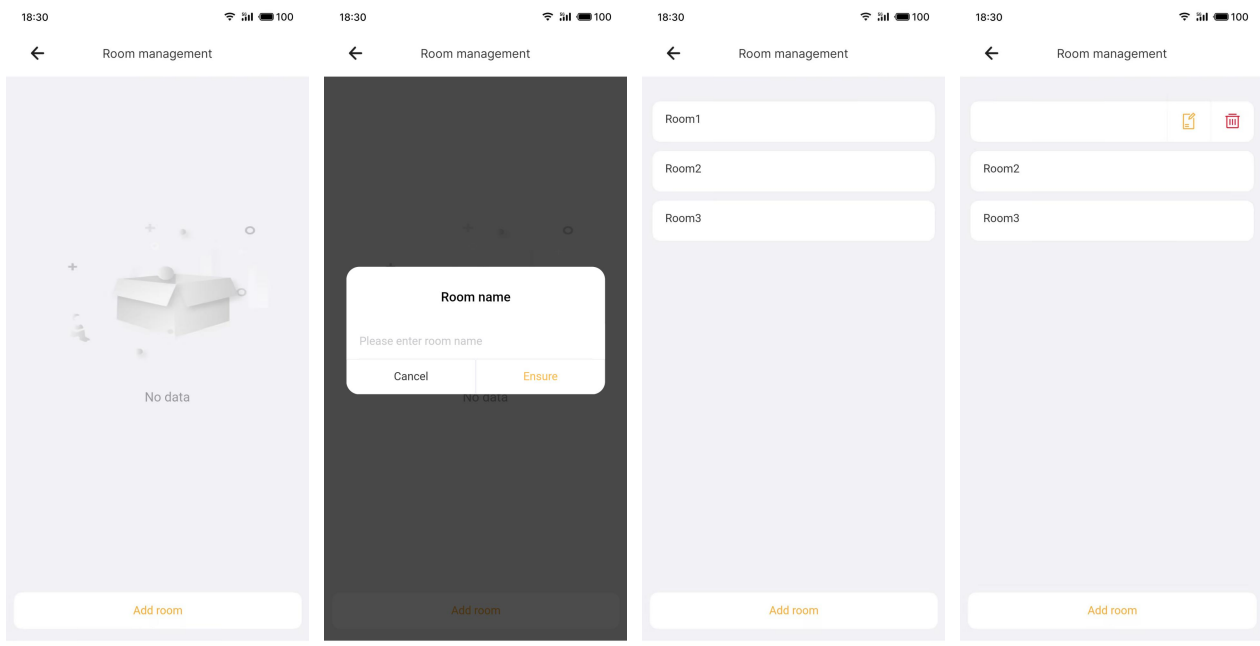

### 5.4.6 Device configuration

Enter device configuration page, and you can add and manage devices on this page. Take the device type of switch as example to explain:

#### (1) Add device

Click icon “+” to add a device, set the following information to complete the addition. Or click the icon ← to cancel addition:

**【Device name】** : set the description of device name, and it can not be empty.

**【Area】** : click to select the room to which the device belongs. If there is no appropriate rooms, you can create a new room here.

**【Product type】** : click to select device type. The detail please refer to [Chapter 5.12](#).

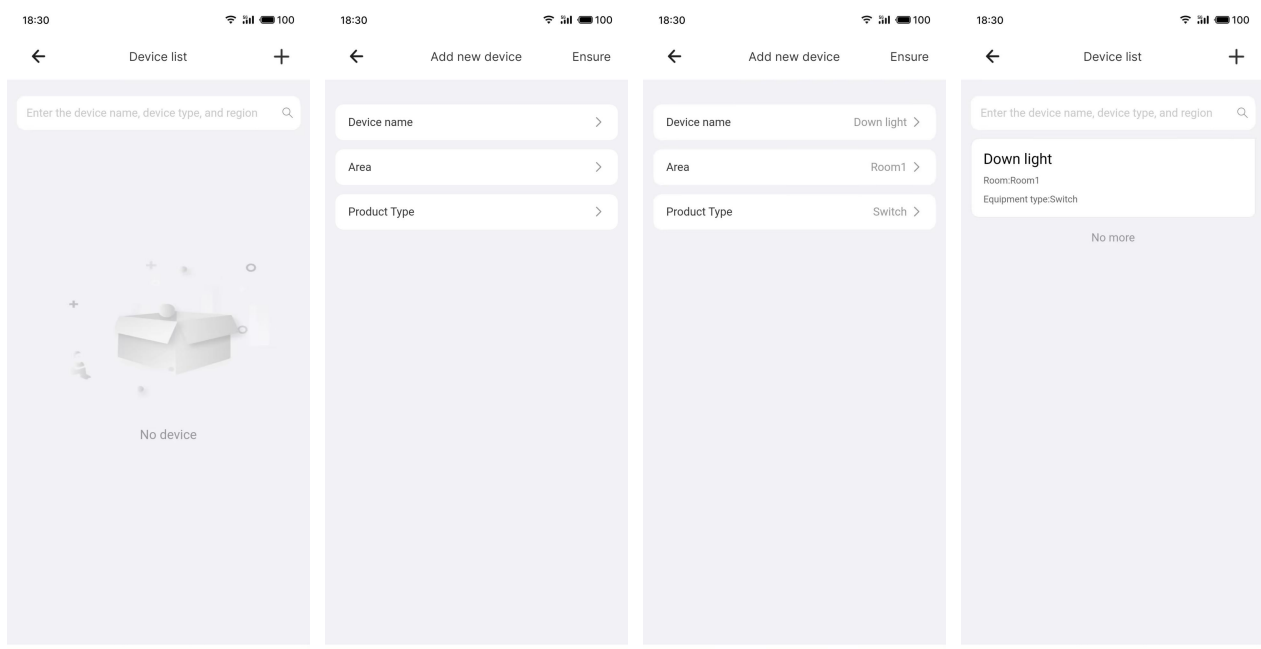

## (2)Edit device

Select a device to enter edition page, set the following information:

The screenshot shows a mobile application interface for editing a device. At the top, the time is 18:30 and the battery is at 100%. The device name is 'Down light' and the area is 'Room1'. The device type is 'Switch'. Under 'KNX configuration', there are two input fields for 'Switch operation group address' and 'Switch status group address', both currently set to '0/0/0'. The '485 configuration' section has a toggle switch turned off and three input fields: 'Interface serial number' (with a 'Click to select' button), 'Device protocol library file' (with a 'Product name-Mode' dropdown), and '485 address' (with a 'Please enter 485 address' prompt). At the bottom, there is a 'Controlling device' field with an upward arrow and a message: 'The configuration has not been issued yet and the value cannot be controlled'. A 'Get device properties' button is at the very bottom.



【Device name】 : display the name of device.

【Area】 : display the room to which the device belongs. If the room is deleted, this field will display as blank, allowing for the reassignment to a new room.

【Device type】 : display the selected device type, which is set and cannot be altered further.

【KNX configuration】 : based on the chosen device type under the category of 【Device type】 , this section showcases the available operation group addresses and status group addresses that can be configured. Take the switch type device as example, only two group addresses are displayed: "Switch operation group address" and "Switch status group address". Click the input box on the right, enter the group address manually, the input range is 0..31/0..7/0..255, such as 1/1/1; Click the object name on the left to jump to the XML file interface, you can directly select the required group address on this interface. For details about how to import XML files, please see [Chapter 5.7](#). Initially, the group address



is set to 0/0/0, it is an invalid address. No modify implies no KNX configuration, thereby no KNX communication.

【485 configuration】 : if activate the button , the following 485 configurations are effective; if deactivated , they remain inactive, and can not to 485 communicate:

Interface serial number: select a serial number for 485 interface, optional range is 1~6.

Device protocol library: display the 485 file name after selected 485 serial number. If there is no file, please refer to [Chapter 5.4.4](#), to set a file.

485 address: enter the 485 address of the device, allowing only for numbers and letters between 0 and 9, a and f, representing hexadecimal values like 32ff, 321, and f0. [Multiple devices can be configured under the same interface, each corresponding to different 485 addresses. For address configuration specifications, please refer to the protocol document for address bit definitions.](#)

【Dry contact】 : if it is a dry contact device, such as a "General IO Device", it is necessary to configure the dry contact interface. Activating the button , the setting of interface serial number is effective, offering a optional range from 1 to 5. Conversely, deactivating the button  renders this configuration invalid.

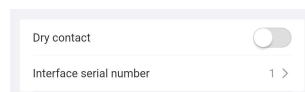

【Controlling device】 : verify the operational effectiveness of configured control functions. Depending on the selected device type, display the control operations. Take the switch type device as example, the controls include "ON" and "OFF", allowing users to send the corresponding control values upon clicking.

[Note: control values cannot be sent when configurations have not been download to gateway.](#)

【Get device properties】 : read the feedback status values from the device, ensuring the functionality of device control. Depending on the selected device type, display the statuses. [Note: no status feedback when configurations have not been download to gateway.](#)

### (3) Save/Cancel edit

Upon completing the device edits, clicking on the upper right corner's "Confirm" to save all edits and return to the device list interface. Alternatively, selecting the return icon ← in the upper left corner will prompt a pop-up window to select: opting for "Save and back" saves all edits and navigates back to the device list interface, while choosing "Back" abandons all edits directly.

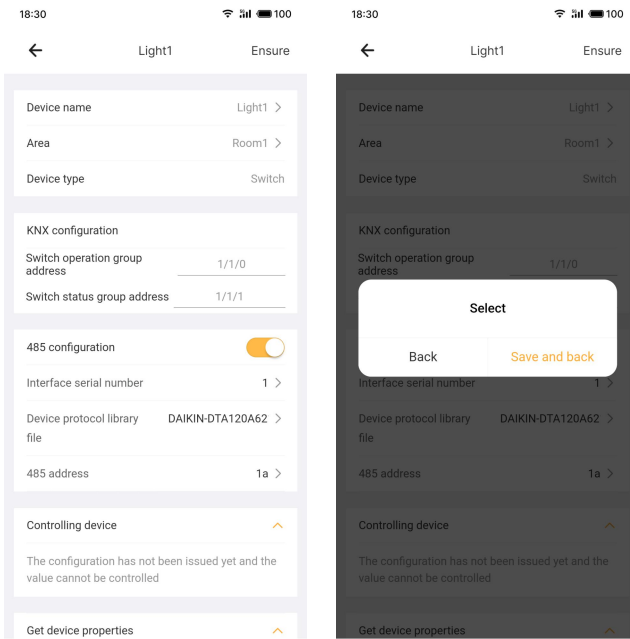

(4)View/Delete/Copy device

Complete device setting, you can view it in the device list, showcasing information such as the device name, device type, and room. If the associated room has been deleted, this field displays as empty. Utilize the search bar to swiftly locate a device by device name, or room name.

Slide left on the device list to select icon  , click and confirm to delete a device and all associated configurations.

Slide left on the device list to select icon  , click and set the quantity to be copied, up to 10 devices can be copied at a time. The copied device names will have serial numbers added to the original names, such as "xxx01", "xxx02", "xxx03"...

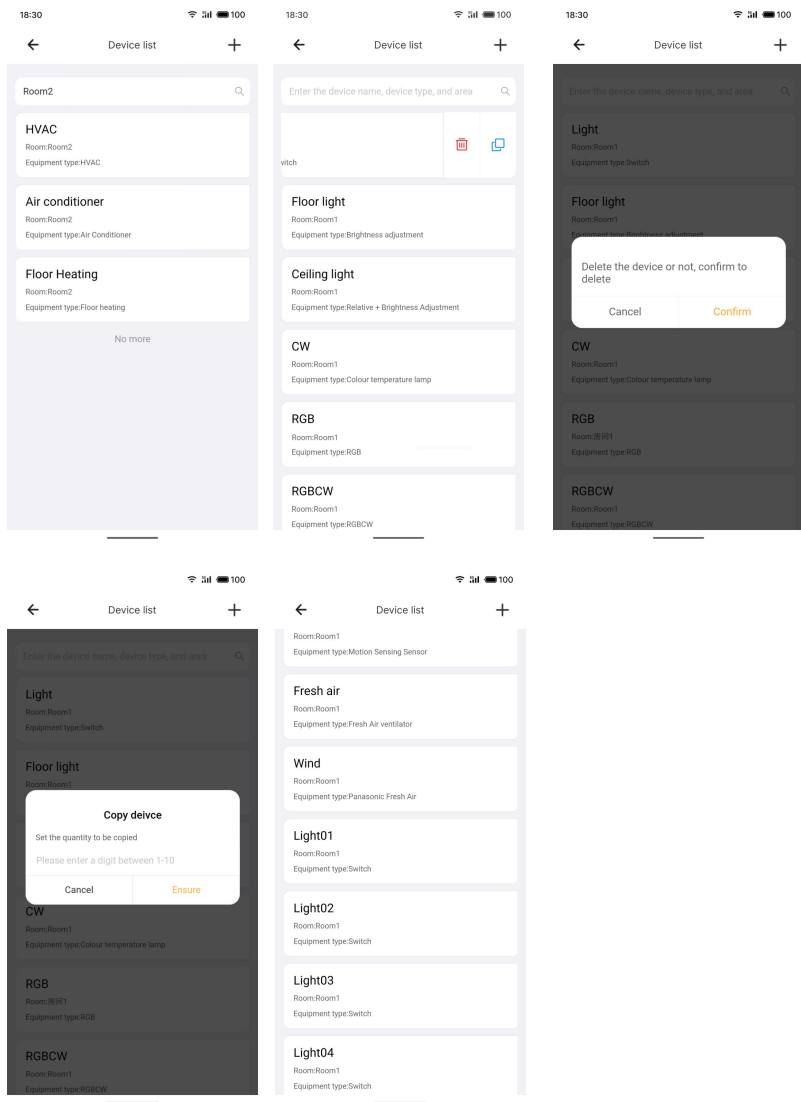

### 5.4.7 Scene configuration

Enter scene configuration page, and you can add and manage scenes on this page.

#### (1) Add scene

Click icon “+” to add a scene, set the following information to complete the addition. Or click the icon to cancel addition:

**【Scene name】** : input scene’s name description, it is prohibited to use special character other than Chinese, English, and numbers, such as “Scene1”. Avoid typing any other special characters, and ensure that the field is not left empty.

**【Scene ID】** : click to input KNX scene ID, optional range is 1~64.

**【Scene location】** :click to select the room to which the scene belongs. If there is no appropriate rooms, you can create a new room here.

**【Scene background】** : click to choose a background and it will display in the scene list.

**【Group address】** : click to input group address for the scene. The input range for group addresses is 0..31/0..7/0..255, such as 1/1/1. **Initially, the group address is set to 0/0/0, it is an invalid address.**

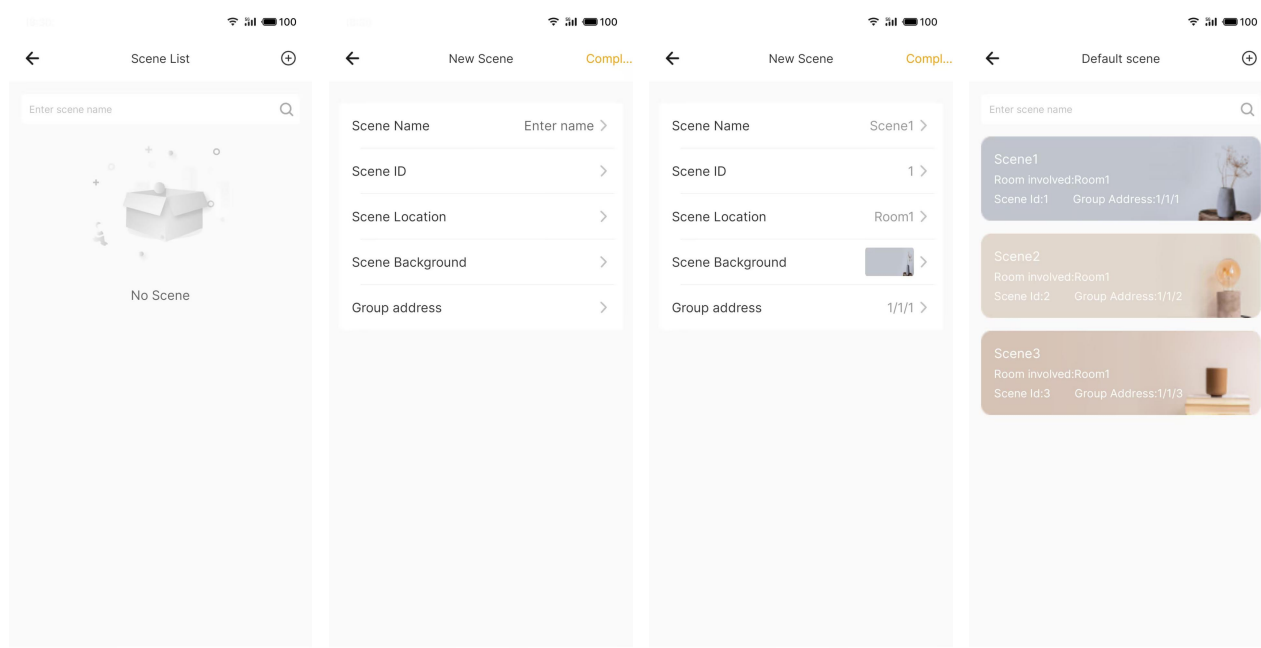

## (2)Edit scene

Select a scene to return edit page, to modify the scene name, ID, location, background and group address, complete the modification and save. Or click the icon ← to cancel addition/edition:

## (3)View/Delete/Copy scene

Complete scene setting, you can view it in the scene list, showcasing information such as the scene name, ID, location, background and group address. If the associated room has been deleted, this field displays as empty. Utilize the search bar to swiftly locate a device by scene name.

Slide left on the device list to select “Delete”, click and confirm to delete a scene and all associated configurations.

Slide left on the device list to select “Copy”, click and set the quantity to be copied, up to 10 scenes can be copied at a time. The copied scene names will have serial numbers added to the original names, such as "xxx01", "xxx02", "xxx03"...

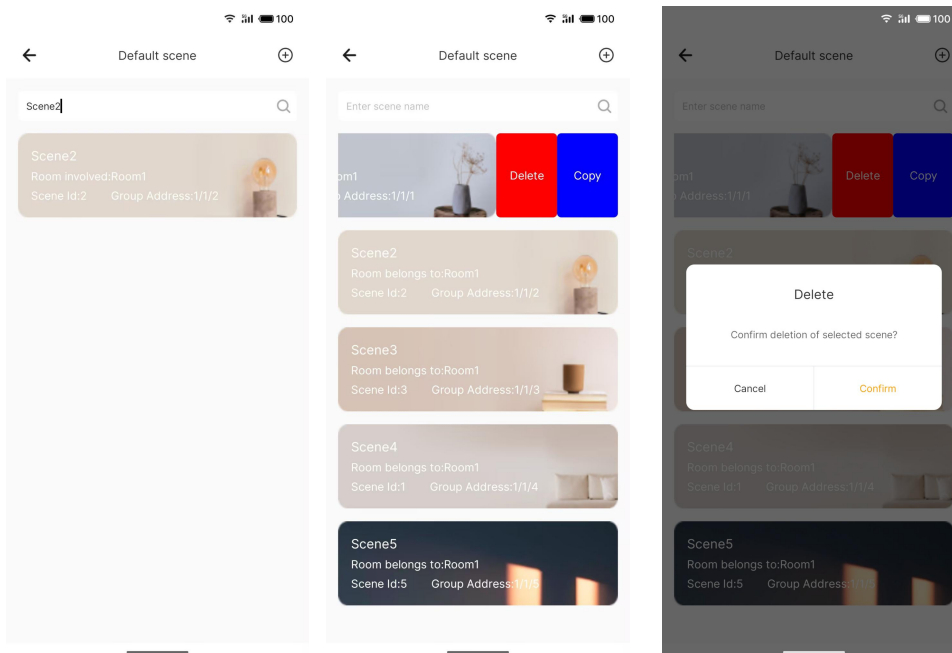

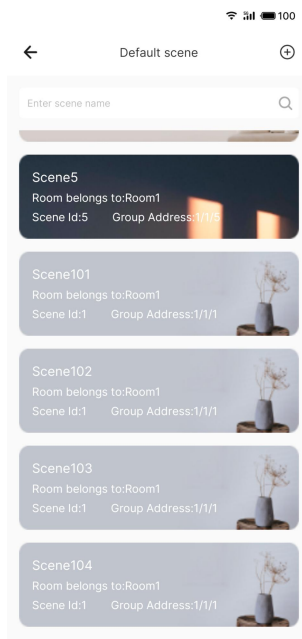
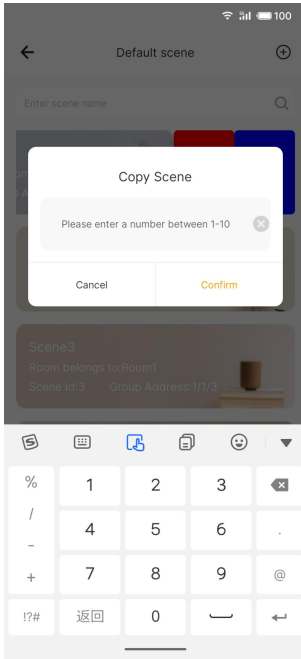

### 5.4.8 Automation Scene Configuration

Enter automation scene configuration page, and you can add and manage scenes on this page.

#### (1) Add scene

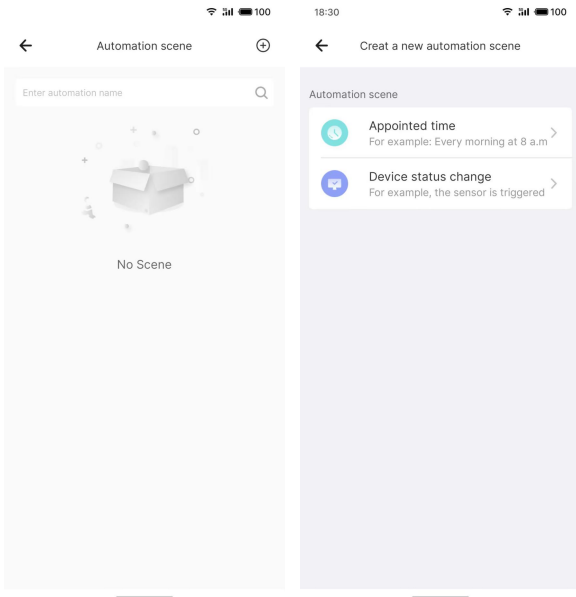

Click icon “+” to add a scene, access the addition interface, you can set various trigger conditions: “Appointed time” or “Device status change”. Detail please refer to step (3).

#### (2) Add basic information

**【Scene name】** : input scene’s name description, it is prohibited to use special character other than Chinese, English, and numbers, such as “LeaveHome”. Avoid typing any other special characters, and ensure that the field is not left empty.

**【Scene background】** : click to choose a background and it will display in the scene list.

**【Effective period】** : click to set an effective period and a repeat period for automation scene. Once set, during this time period if the automation meets the set conditions and the task has not yet been performed, the task is executed. You can choose Whole Day, Day Time, Night Time or Customize Time as effective period, and the Customize Time need to set a starting time and End time, such as 9:00~18:00. And repeat period is optional Monday~Sunday, or at least one day.

**【Select the associate room】** : click to select the room to which the scene belongs. If there is no appropriate rooms, you can create a new room here.

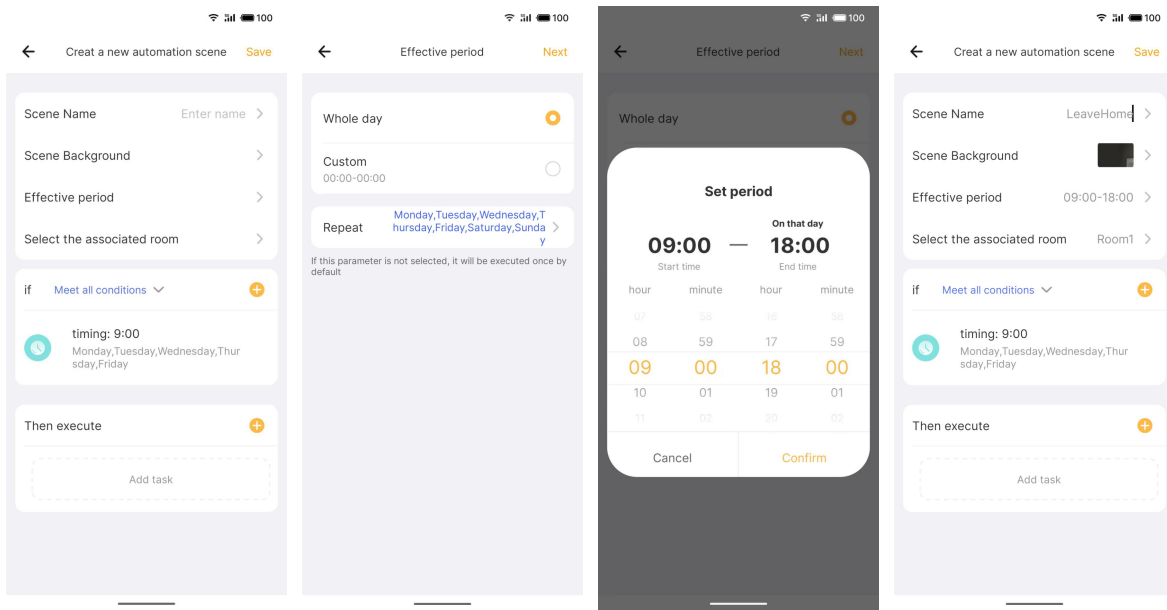

**(3)Add condition**

You can add various trigger conditions by the “If” item: “Timing” or “Device status change”.

**【Operation of condition】** : Select “Meet all conditions” or “Meet either condition”.

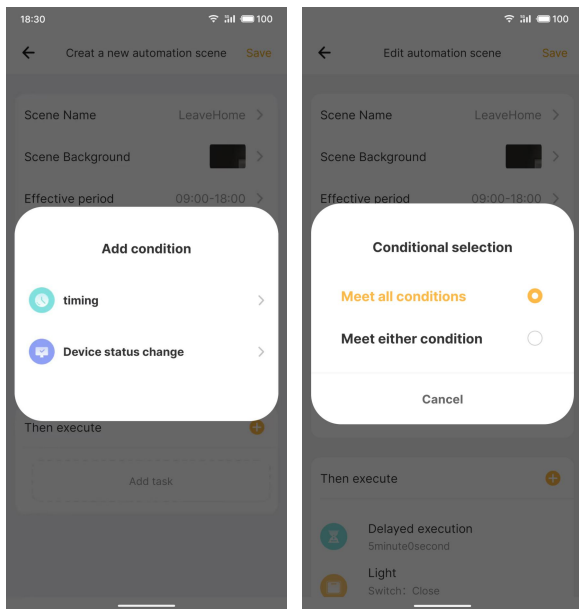

**【Timing】** : set the timing, after setting, you can see or modify it in the condition list.

1) **【Set execution time】** : sliding the number to set the execution time for conditions, allowing configuration of the hour and minute.

2) **【Repeat】** : it is optional Monday~Sunday, if no option is selected, the schedule is executed only once by default.

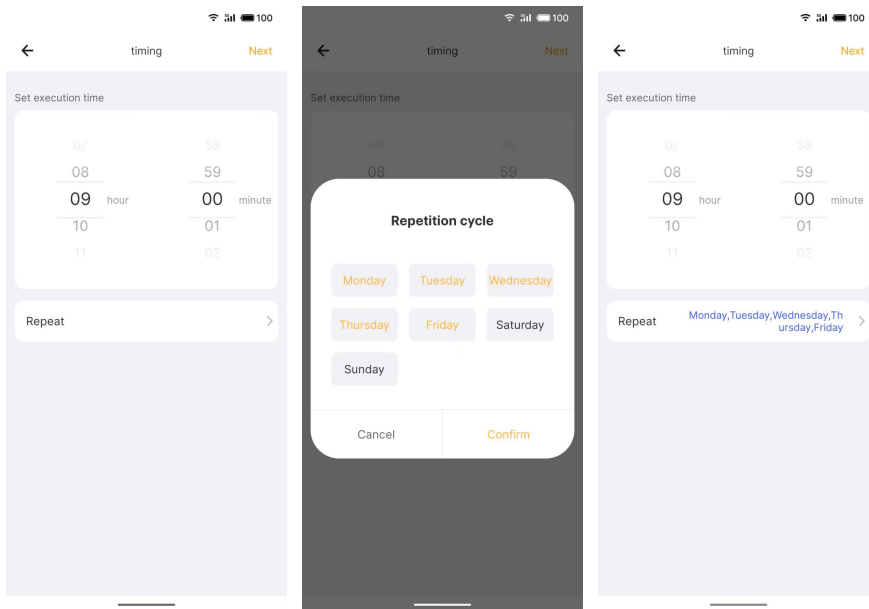

**【Device status change】** : choose a device to set condition, take the light as an example, set to "Open",

after setting, you can see or modify it in the condition list.

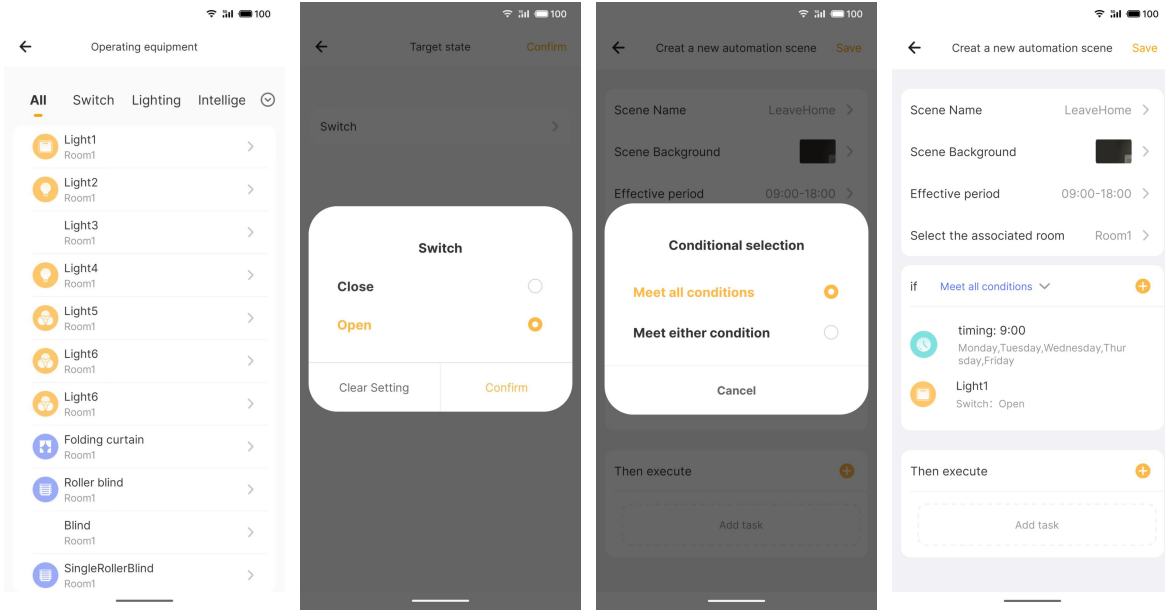

**(4)Add task**

You can add various execution tasks by the “Then execute” item: “Operating equipment” or “Delayed”.

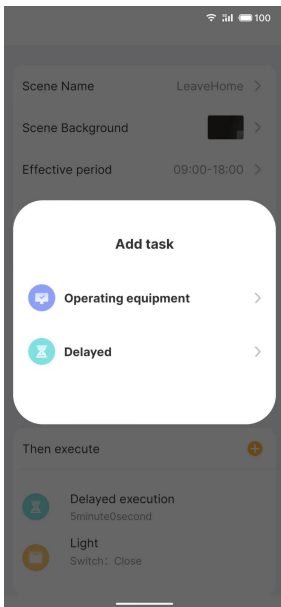

**【Operating equipment】** : choose a device to set task, take the light as an example, set to “Close”, after

setting, you can see or modify it in the condition list.

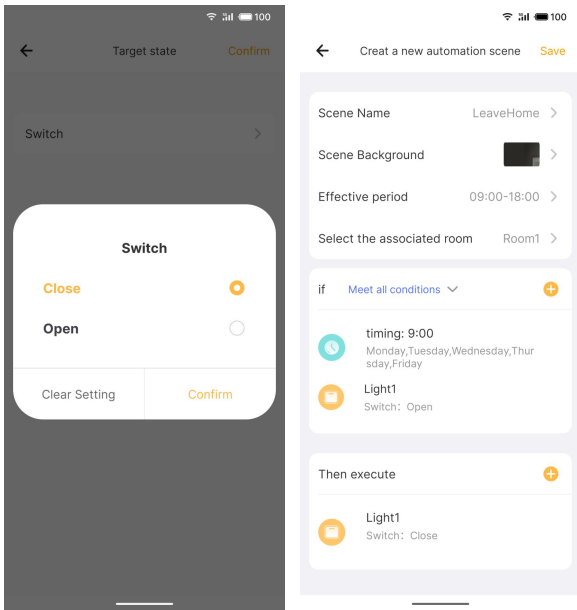

**【Delayed】** : click to pop-up a setting window, sliding the number to set the delay time for tasks, allowing configuration of the hour and minute. After setting, you can see or modify it in the condition list.

Note: 1) Two delays cannot be added consecutively; 2) Delay cannot be the last task, otherwise the settings cannot be saved; 3) Up to 20 delays can be added in a scene.

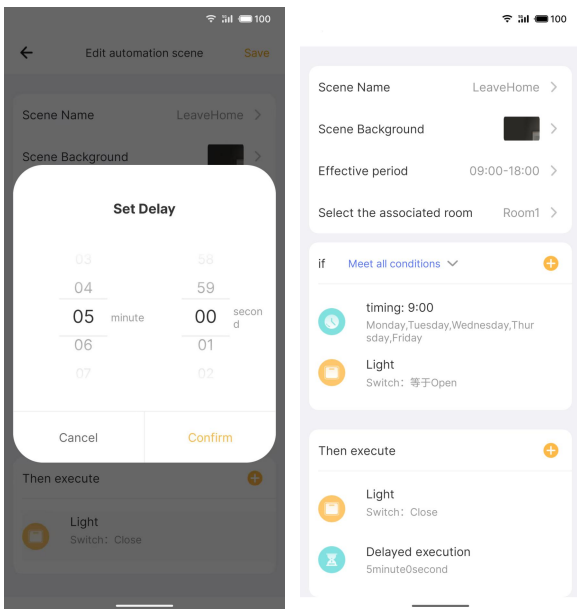

(5) Save/Cancel edit

Upon completing steps (1) to (5), and save the configurations then return to the scene list. Click

the top-left return icon  is cancel the new addition.

#### (6)View/Delete/Copy scene

Complete scene setting, you can view it in the scene list, showcasing information such as the scene name, location, effective period. If the associated room has been deleted, this field displays as empty. Utilize the search bar to swiftly locate a device by scene name.

Slide left on the device list to select “Delete”, click and confirm to delete a scene and all associated configurations.

Slide left on the device list to select “Copy”, click and set the quantity to be copied, up to 10 scenes can be copied at a time. The copied scene names will have serial numbers added to the original names, such as "xxx01", "xxx02", "xxx03"...

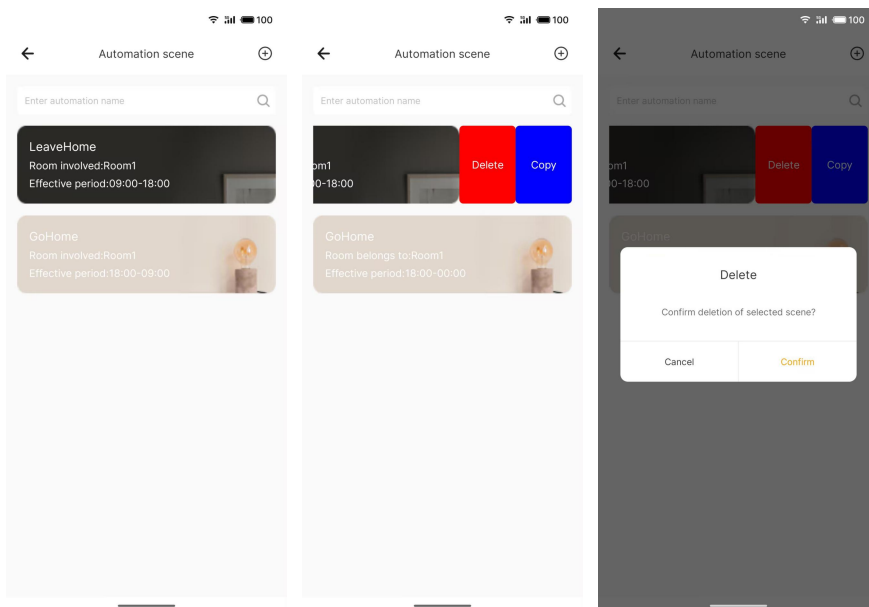

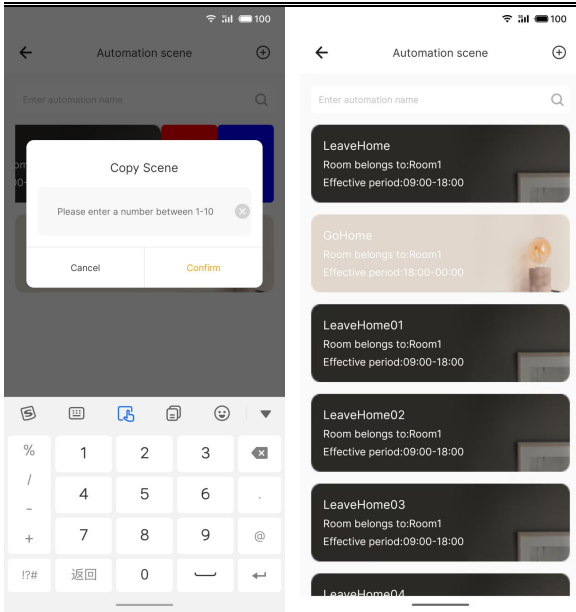

### 5.4.9 Download configuration

Upon ensuring the completion of all configurations, click the button to download the configuration file to the gateway for validation.

Note: upon successful download of the configuration file, the gateway will have a restart, then broadcast again. The configuration file will overwrite the previously downloaded file.

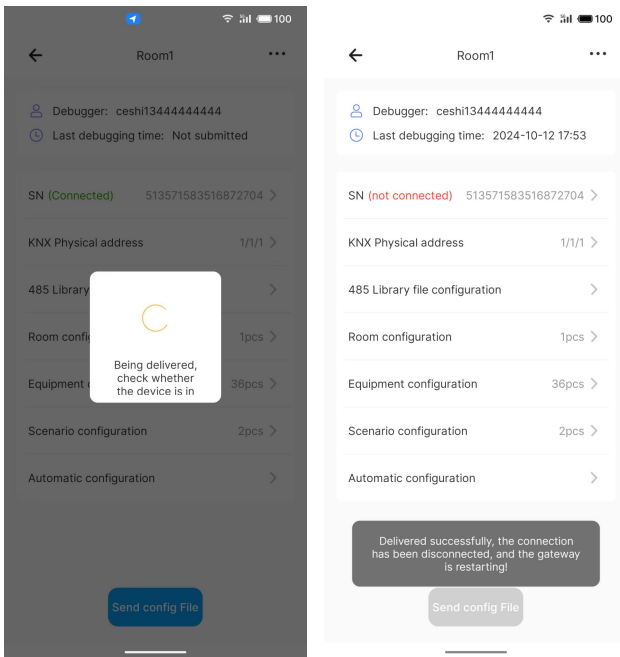

### 5.5 Gateway information

Click on the icon **...** in the upper right corner of the setting interface to access gateway information page. The operation can only be operated after connecting to a gateway.

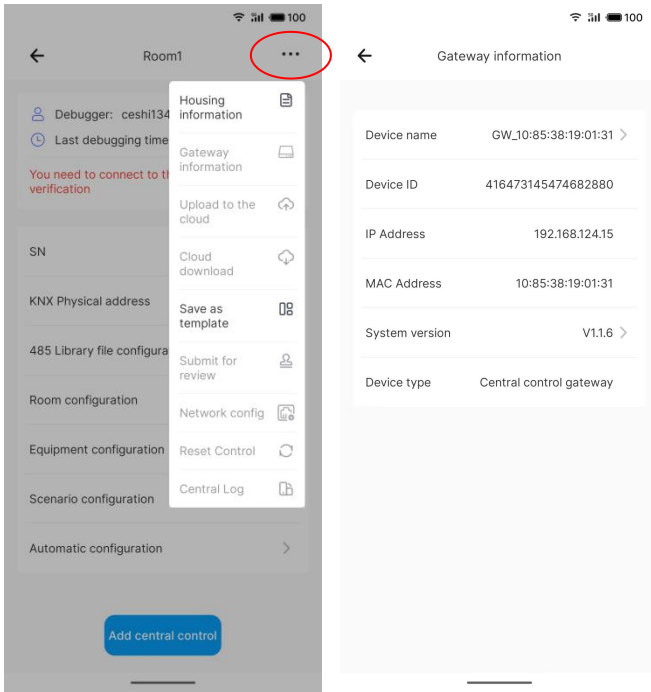

**【Device name】** : click to change name, it can be downloaded to gateway.

**【Device ID】** : the unique serial number, for identifying and locating the gateway.

**【MAC Address】** : display MAC address of gateway.

**【System version】** : display the system version of gateway, click to access the update page. A notification will appear in the top right corner **...** of the setting interface if a new version is detected. The operation of gateway OTA update, please refer to [Chapter 5.9](#).



**【Device type】** : display "Central control Gateway" by default, corresponding to GVS Smart APP.

## 5.6 Network configuration

Click on the icon **☰** in the upper right corner of the setting interface to access network configuration page. The operation only can be operated after connecting to a gateway.

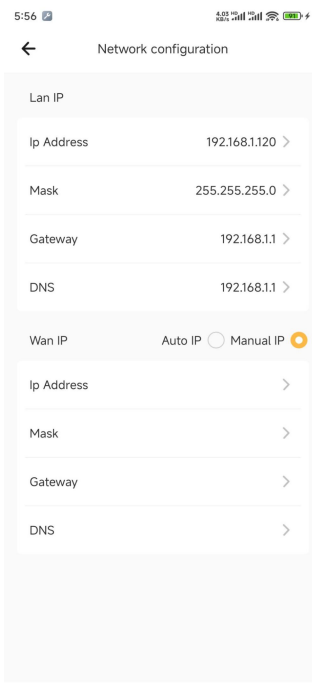

**【LAN IP】** : access the Network config page to view/set the IP address, subnet mask, gateway, and DNS.

**【WAN IP】** : access the Network config page to choose between "Auto IP" or "Manual IP." When selecting manual, input the IP address, subnet mask, gateway, and DNS settings.

## 5.7 Import XML

Within the general setting interface of building, click on the icon **⋮** in the upper right corner to select "Import XML" to import the setting of Group Addresses so that they can be directly used for the device.

Click "Import a new XML file" below to import the local file (format .xml), after the successful import, you can see it in the list. Click the file in the list to view and search the specific group address.

Swiping left an item of XML list to delete. The deletion will not affect the group address associated with the device.

If the imported file is incorrect or damaged, it will prompt "XML file format exception".

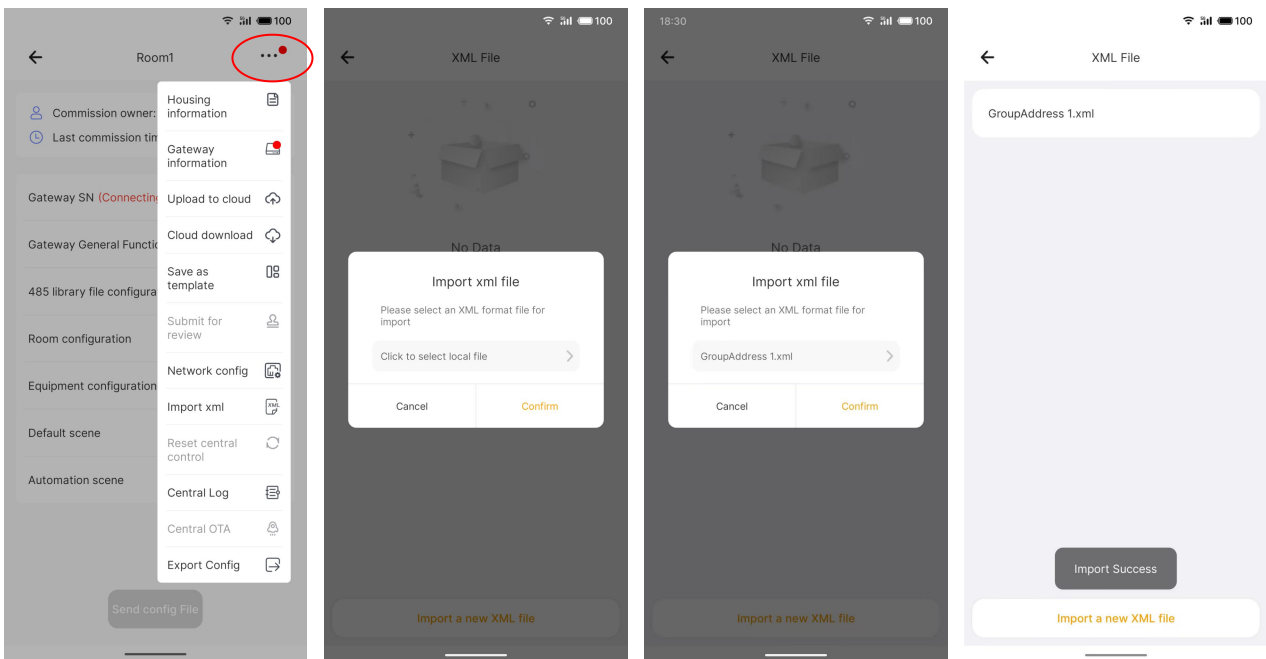

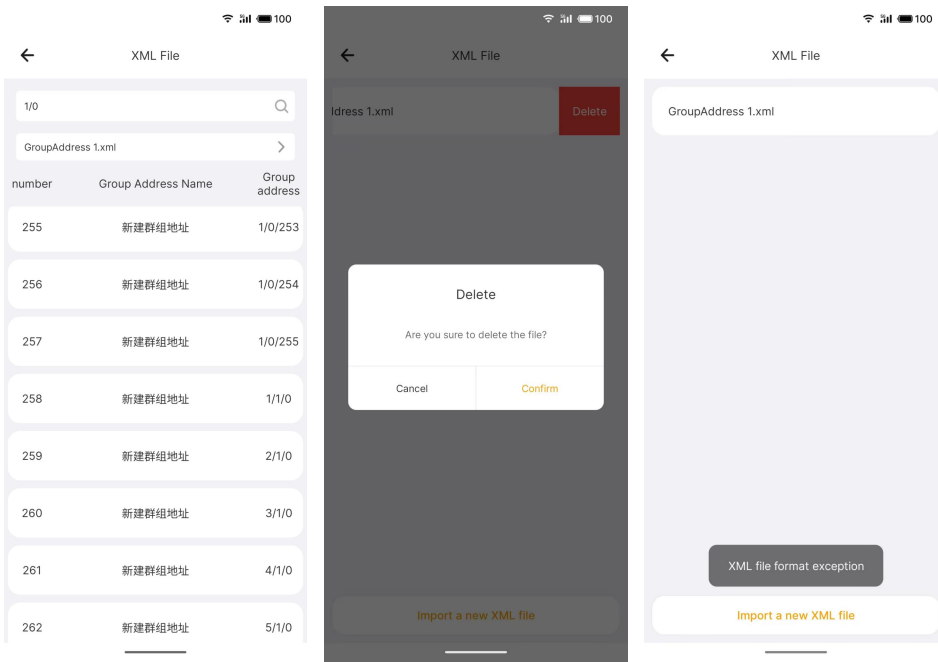

**xml file can be created and exported from the ETS software, the operation steps are as follows:**

1. In ETS to create a new project, enter the project view, switch to the workspace of Group Address.

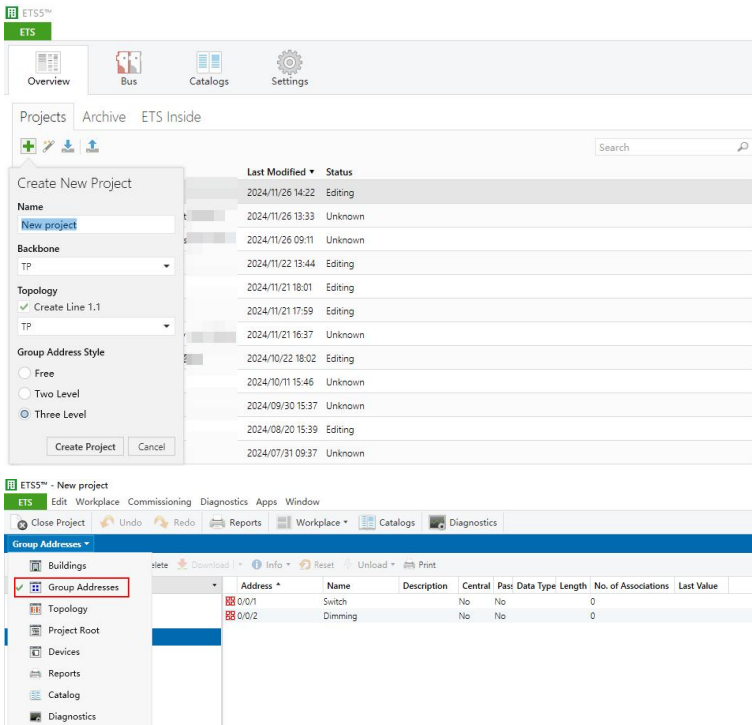

2. Then in this interface in turn to establish the Main Group, the Middle Group, Group Address.

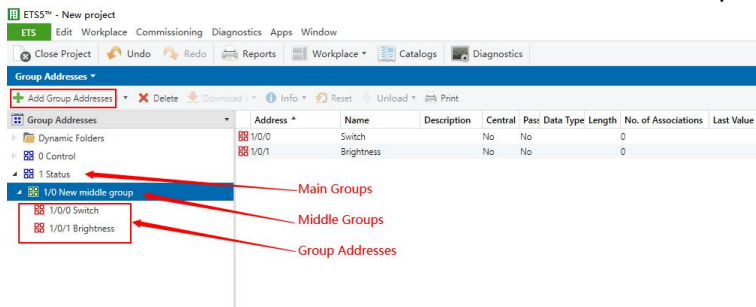

3. Then, choose to export these group address information in xml format. The exported file can then be used to import into the APP.

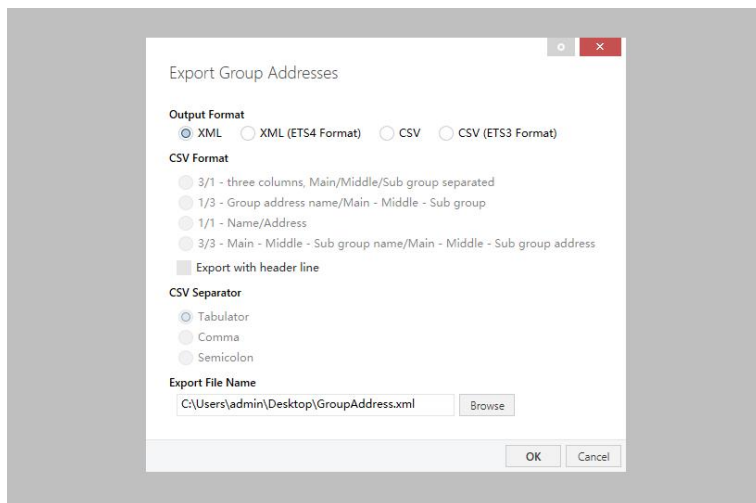
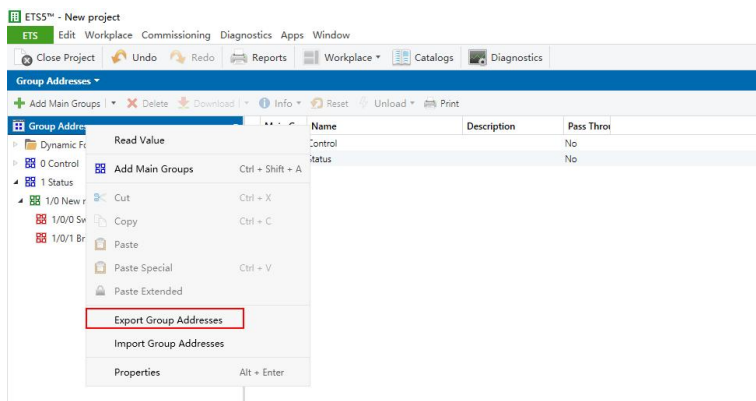

## 5.8 Central log

Click on the icon  in the upper right corner of the setting interface to access central log page.

Click the icon  to synchronize the logs of the gateway.

Choose a log, click to download, then navigate to a local path, select a folder, and save the log file in .log format. Afterward, return to the list, click again to access and review the selected log.

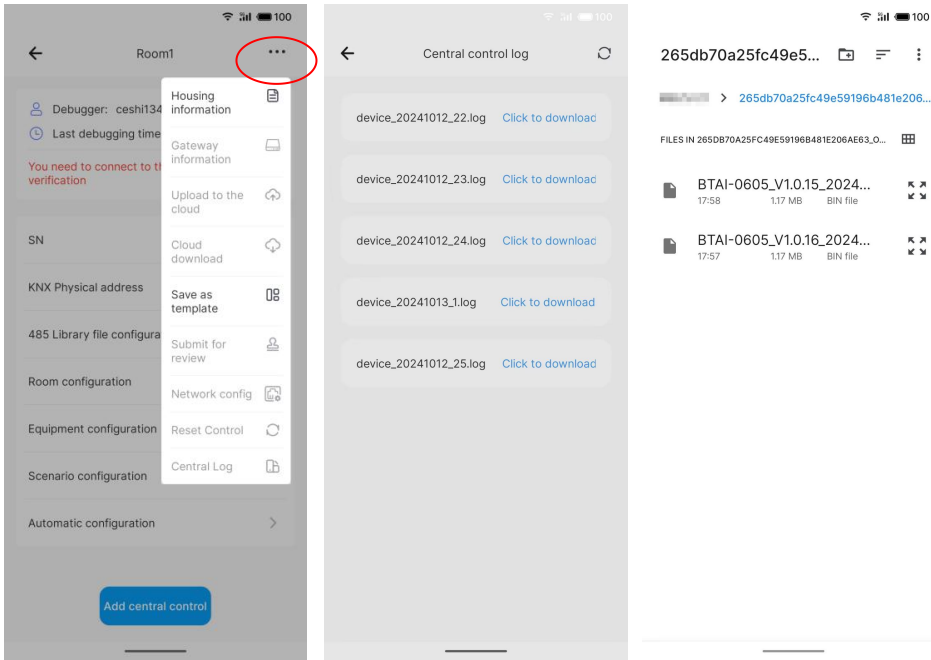

## 5.9 Gateway OTA

KNX Multifunctional Gateway can undergo firmware upgrades (OTA) via APP. Follow the steps below:

### (1) New version release

On the building settings page, if a new version is detected, a red dot indicator will appear in the top right corner of the interface. If a new firmware has been released but no upgrade notification is received on APP, or if there are any queries regarding the latest firmware version, please contact GVS technical support.



### (2) Firmware upgrade process

Select the version to be upgraded firstly and download it locally before upgrade. On the upgrade interface, all cloud firmware versions can be viewed, the new versions shown as "Click to download" and downloaded versions as "Update gateway".

**【Click to download】** : click to download the upgrade package; download progress is displayed on the right side of the list and can continue in the background. Upon completion, a "Download Successfully" prompt appears. If the download remains incomplete after 15 minutes, the process is failure.

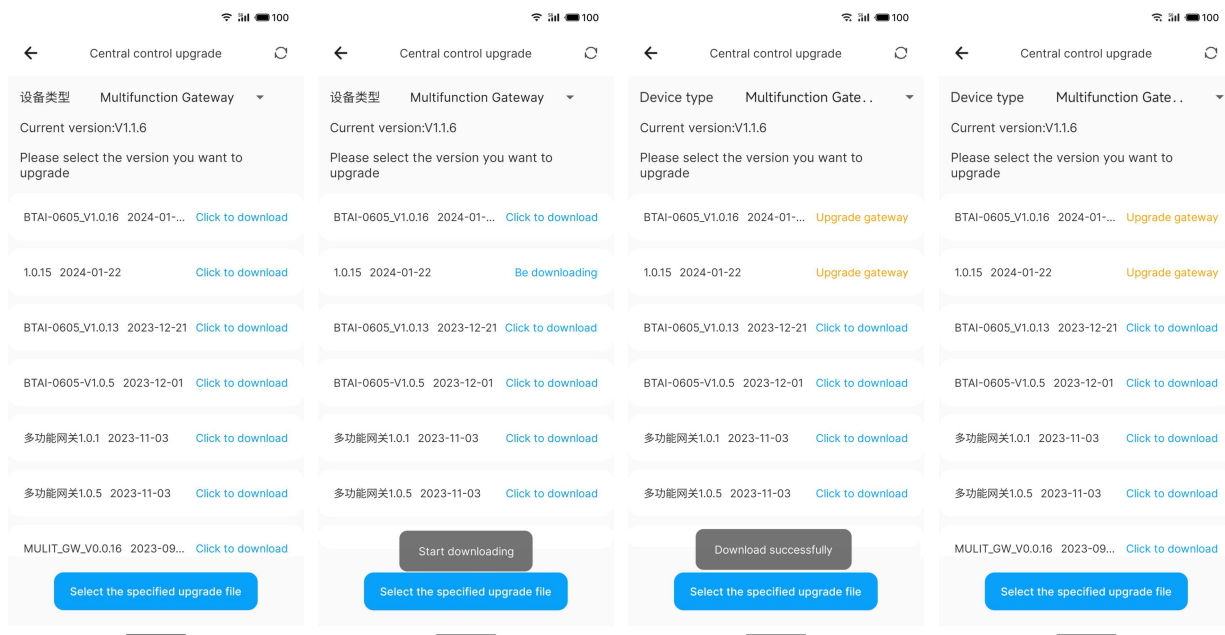

**【Update gateway】** : confirm the pop-up window to start upgrade. Please do not do anything at this time. After waiting for approximately 1 minute and receiving a prompt indicating successful download, **do not exit the APP, otherwise the upgrade result can not be obtained.** Throughout the update process, ensure voltage power and network normally for the gateway, the device is unusable at the moment. Once the "Current version" displays the latest firmware version, the upgrade is successful.



**(3) Upgrade failure**

In the event of an upgrade failure, check the device connection between the gateway and the APP, then retry the download process.

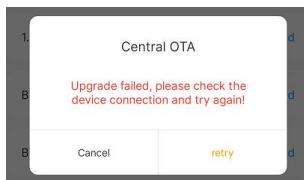

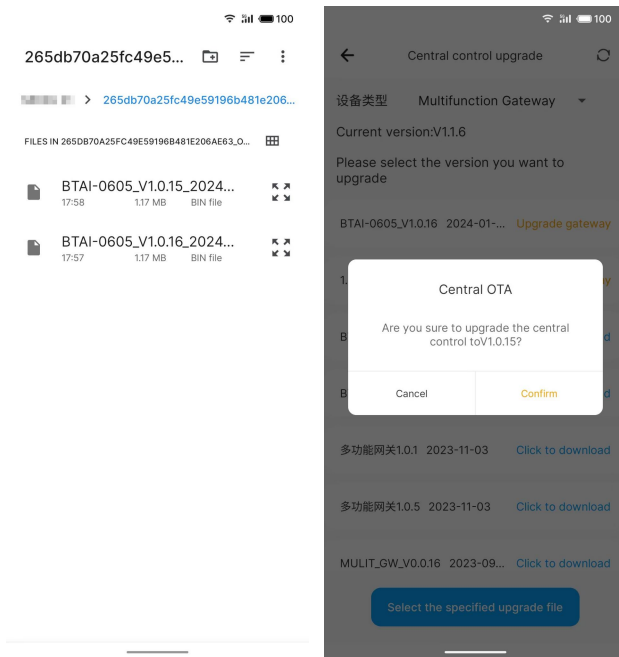

#### (4) Temporary upgrade

On the upgrade interface, click "Select the specified upgrade file", navigate to a local path, choose a version file for upgrade, and confirm to proceed with the upgrade. This procedure is typically utilized for temporary upgrades.



## 5.10 Template Management

In the building settings interface, selecting "Save as template" allows the configuration file to be saved as a cloud template, enabling easy access and management in the "Cloud Example".

Cloud templates are organized based on project management, showcasing details such as project name and the number of templates. Quick searches can be performed by entering project or template names in the search bar. Select a project, all its associated configuration templates can be viewed, sync the latest cloud templates by clicking the icon  in the top right corner of the interface. The download status of templates is displayed on the right side of the list, the icon  indicates the template has not been downloaded locally.

Corporate administrator or project managers have the authority to view all templates uploaded to the cloud. However, the account with an engineer role is restricted to only viewing templates from authorized projects and are unable to access unauthorized ones.

Once a template is downloaded locally, it can be viewed in the "Local example", showcasing details like template names, room numbers, device quantities, and project location. Quick searches can be performed by entering project names in the search bar. **Templates can only be utilized by local projects once they have been successfully downloaded to the local.**

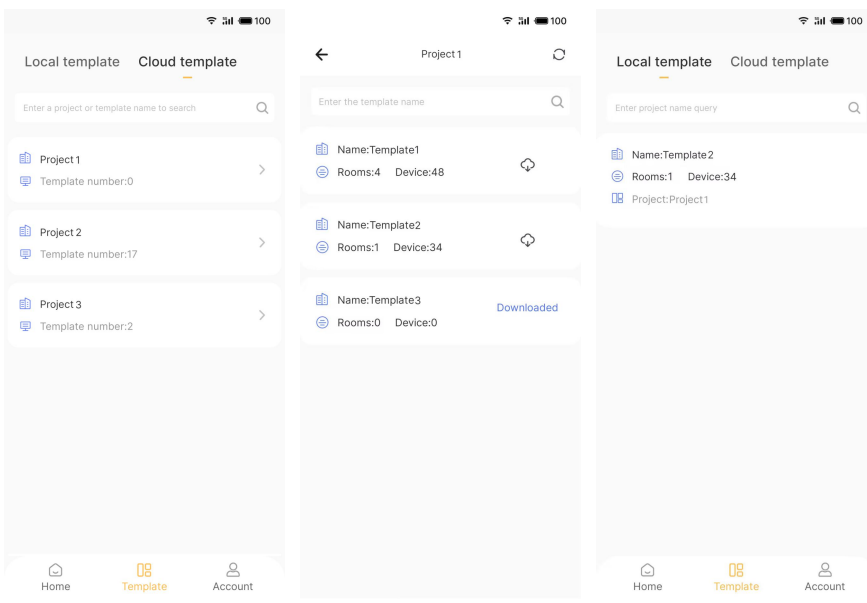

## 5.11 User Center

Upon successful login, navigate to access the user center, as following below:

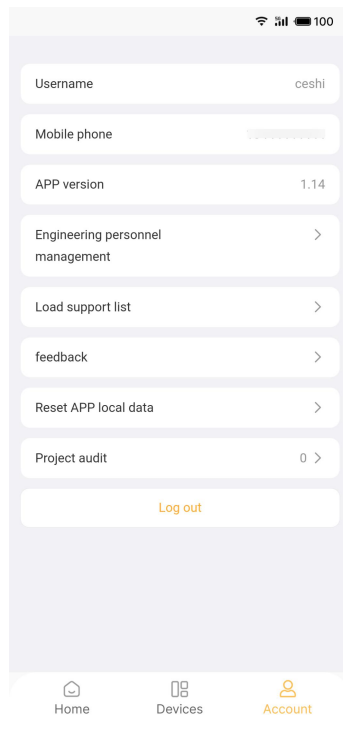

**【My Account】** : click to view the account information , more details please refer to [Chapter 5.11.1](#).

**【APP version】** : display the current version of APP.

**【Engineering personal management】** : click to view/add/delete authorized personnel for each project.

More details please refer to [Chapter 5.11.2](#).

**【Load support list】** : click to quickly view the load types of devices. More details please refer to [Chapter 5.12](#).

**【Feedback】** : click and enter your comments. You can view them on the platform after submission.

**【Reset APP local data】** : click to pop up the following window. After confirmation, all APP data will be reset, including local projects, local templates, and engineering personnel associations, but the cloud configuration files will not be affected.

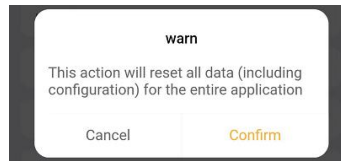

**【Project Review】** : view and process configuration files to be audited. More details please refer to [Chapter 5.11.2.](#)

**【Log out】** : click to pop up the following window, confirm and exit the current account.

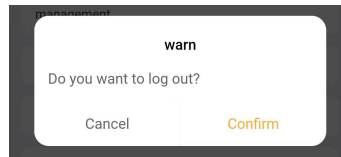

### 5.11.1 My Account management

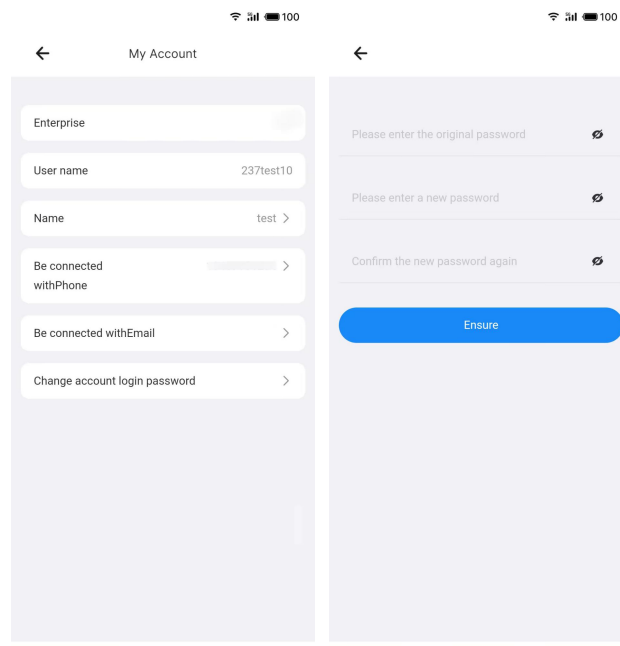

**【Enterprise】** : display the enterprise name and can not be changed.

**【User name】** : it is created by the platform and can not be changed.

**【Name】** : display the account name and can be changed.

**【Be connected with Phone】** : input from the platform and can be changed; if not recorded when create account, please first connect a phone number in the platform then it can be changed in APP.

【Be connected with Email】 : input from the platform and can be changed; if not recorded when create account, please first connect an Email address in the platform then it can be changed in APP.

【Change account login password】 : click to enter the change interface, please first enter the original password, then enter the new password and confirm in twice to complete the change.

### 5.11.2 Engineering personal management

Click 【Engineering personal management】 to view, add, and delete the engineers authorized for each project, the operation steps are described below.

This operation is generally only used to authorize the project to the team member whose role is "Engineer"; the project manager does not need to authorize, and can manage all projects.

Engineers can view the authorized projects in this management interface, but there is no authority to add or delete personnel to the project, while the project manager can.

#### (1)View project

Click 【Engineering personal management】 to enter the management interface to view the project name and the number of authorized person for the project. After a new project is created, the project will be authorized to the person who created the project by default.

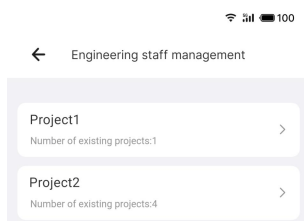

#### (2)View authorized person

Select a project in the management interface, enter the person list interface, and view the user name, cell phone number and role of the authorized person.

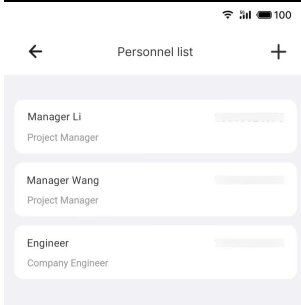

### (3) Add authorization

Click the “+” icon in the upper right corner of the person list interface, the following window pops up, enter the phone number (existing account) of the person you need to authorize to add.

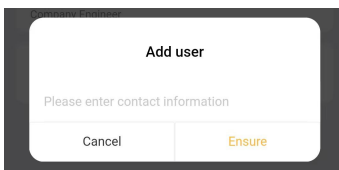

### (4) Remove authorization

In the person list interface, left slide to display the icon , click to pop up the following window, you can delete the engineer after confirming. Upon deletion, the system automatically lifts the authorization between the engineer and the project, and the person will not be able to use the platform or APP to debug the project and device.

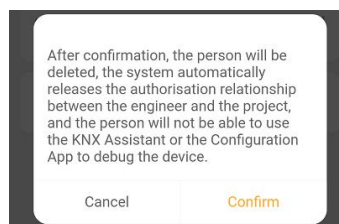
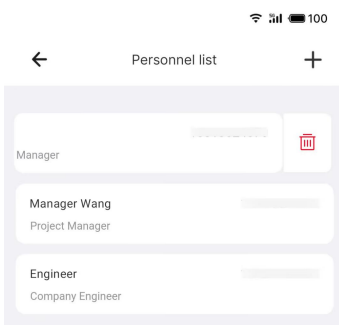

### (5) Change authorization

In the person list interface, you can select one person to change his authorization to project manager or engineer. Note: unable to change the authorization of own account, if you need to change, please do it on the platform.

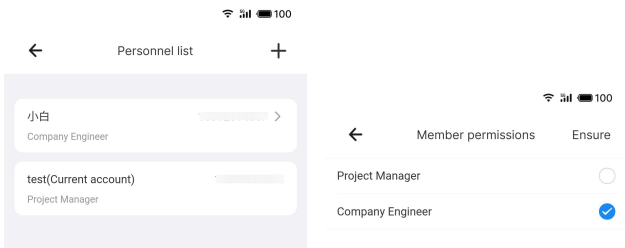

### 5.11.3 Project Review

Click **【Project audit】** to view and process the reviewed and the to be review, the operation steps are described below.

This item is displayed only when you are logged in with the roles of corporation administrator and project manager, as well as having the rights to view and review.

#### (1)Viewing the number of files to be audited

When there are configuration files to be audited, the upper right corner of the **【Account】** icon and **【Project audit】** will indicate the number of items to be audited, for example:

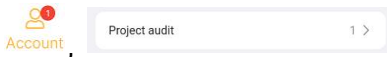

#### (2)Find/Search project

Click **【Project audit】** to enter the project audit list, view the project name and the total number of project buildings, the number of configured buildings and the number of pending audits. Enter the project name in the search bar for a quick query.

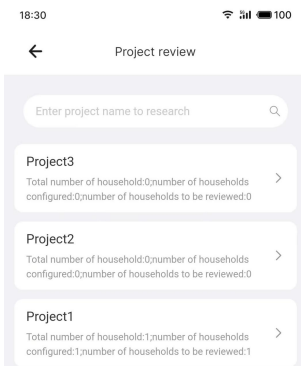

### (3) Find/Audit configuration file

Select a project in the project audit list to enter the project audit interface, view the unaudited list, click [Confirm] on the right side of the list and confirm that the file meets the delivery standards can be submitted, you can also click the upper right corner of the interface for batch audit. Input building name, room name and submitter in the search bar to quickly search for the file that needs to be audited.

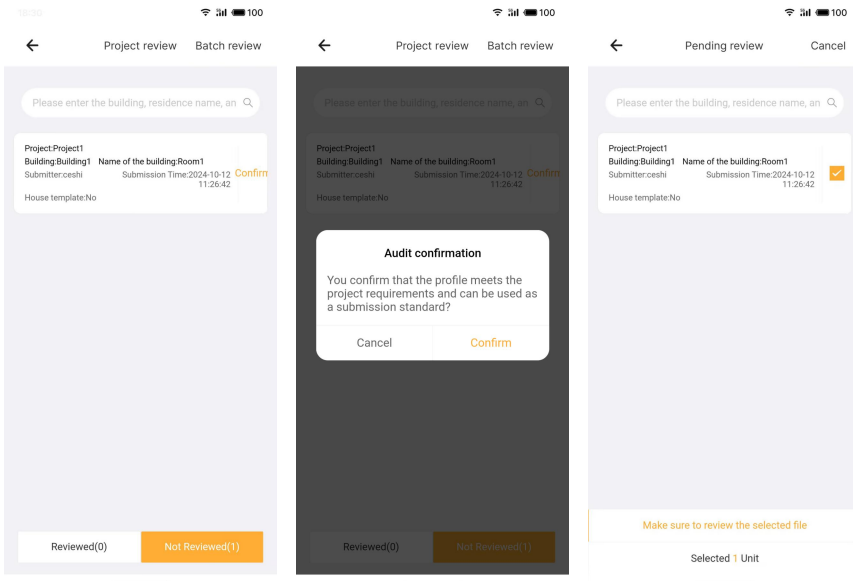

### (4) Restore edit

The audited configuration file can be viewed in the audited list, and the audited does not support updating the cloud configuration.

If you need to reconfigure, click [Restore Edit] on the right side of the list and confirm to restore the editing of the file, then the submitter can reconfigure.

Input building name, room name, and submitter in the search bar to quickly search for the configuration file that needs to be restored.

**Note:** configuration files will automatically restore editing if they are not processed for review within 5 days.

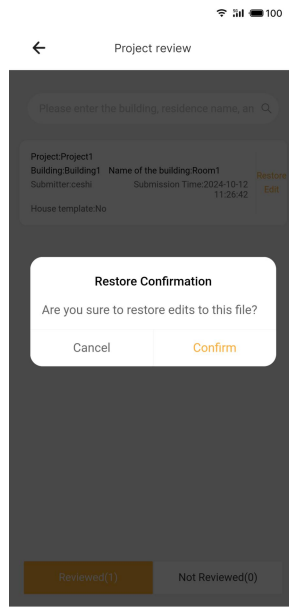
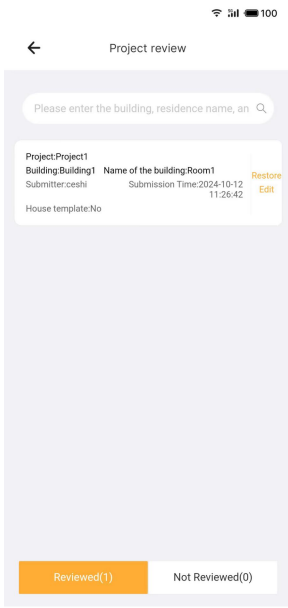

## 5.12 Device type

The "GVS Smart Assistant" APP supports 55 default device types, the following will explain the physical model configuration, KNX configuration, and whether to configure 485 interface or dry contact interface, as well as the sending control commands and the received device status for each device type. Please refer to [Chapter 5.4.6](#) for the steps of device creation and editing.

If the existing device type is not fulfill your requirement, please contact us for more support.

### 5.12.1 Switch

Type of Switch does not require device model configuration; it supports access to KNX devices and 485 devices.

#### 5.12.1.1.KNX configuration

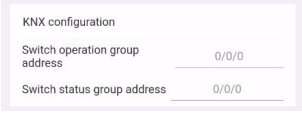
	<p>Switch operation group address</p>	<p>1bit type. Input group address for sending on / off telegrams to the KNX bus to control device.</p> <p>Telegrams: 1 - Turn on the light, 0 - Turn off the light</p>
	<p>Switch status group address</p>	<p>1bit type. Input group address for receiving on / off status from other devices on the KNX bus.</p> <p>Telegrams: 1 - Turn on the light, 0 - Turn off the light</p>

#### 5.12.1.2.Controlling device

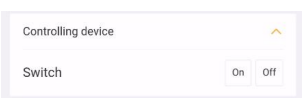
	<p>Switch</p>	<p>There are two control buttons, "On" and "Off", which can be clicked to send the corresponding control commands to the KNX bus or the 485 bus.</p>
---	---------------	--

### 5.12.1.3. Get device properties

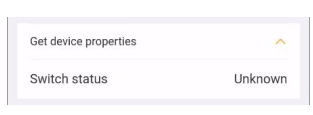
	Switch status	Display the received status, or "Unknown" if not sure.
---	---------------	--

### 5.12.2 Brightness adjustment

Type of Brightness adjustment does not require device model configuration; it supports access to KNX devices and 485 devices.

#### 5.12.2.1. KNX configuration

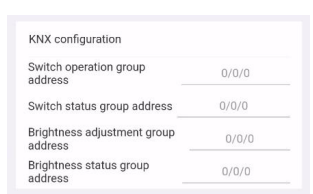
	Switch operation group address	1bit type. Input group address for sending on / off telegrams to the KNX bus to control device.  Telegrams: 1 - Turn on the light, 0 - Turn off the light
	Switch status group address	1bit type. Input group address for receiving on / off status from other devices on the KNX bus.  Telegrams: 1 - Turn on the light, 0 - Turn off the light
	Brightness adjustment group address	1byte Type. Input group address for sending dimming telegrams (brightness value) to the KNX bus to control device.  Telegrams: 0...100%
	Brightness status group address	1byte type. Input group address for receiving brightness status from other devices on the KNX bus.  Telegrams: 0...100%

**5.12.2.2. Controlling device**

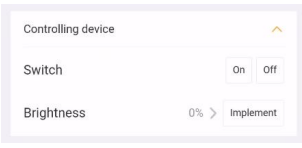
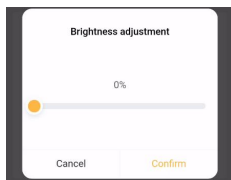
	Switch	There are two control buttons, "On" and "Off", which can be clicked to send the corresponding control commands to the KNX bus or the 485 bus.
	Brightness	Click on the brightness value to pop-up a adjustment window, the adjustable range is 0~100%, after setting, click on "Implement" button to send the value to KNX bus or 485 bus.  

**5.12.2.3. Get device properties**

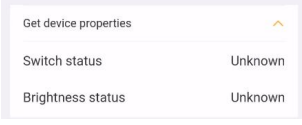
	Switch status	Display the received status, or "Unknown" if not sure.
	Brightness status	Display the received status, or "Unknown" if not sure.

### 5.12.3 Relative+Brightness adjustment

Type of Relative+Brightness adjustment does not require device model configuration; it supports access to KNX devices and 485 devices.

#### 5.12.3.1.KNX configuration

<div style="border: 1px solid black; padding: 5px; margin-bottom: 10px;"> <p>KNX configuration</p> <p>Switch operation group address <span style="float: right;">0/0/0</span></p> <hr/> <p>Switch status group address <span style="float: right;">0/0/0</span></p> <hr/> <p>Relative dimming operation group address <span style="float: right;">0/0/0</span></p> <hr/> <p>Brightness adjustment group address <span style="float: right;">0/0/0</span></p> <hr/> <p>Brightness status group address <span style="float: right;">0/0/0</span></p> <hr/> </div>	<p>Switch operation group address</p>	<p>1bit type. Input group address for sending on / off telegrams to the KNX bus to control device.</p> <p>Telegrams: 1 - Turn on the light, 0 - Turn off the light</p>
	<p>Switch status group address</p>	<p>1bit type. Input group address for receiving on / off status from other devices on the KNX bus.</p> <p>Telegrams: 1 - Turn on the light, 0 - Turn off the light</p>
	<p>Relative dimming operation group address</p>	<p>4bit Type. Input group address for sending relative dimming telegrams to the KNX bus to control device, such as brighter, darker, or stop-dimming.</p>
	<p>Brightness adjustment group address</p>	<p>1byte Type. Input group address for sending dimming telegrams (brightness value) to the KNX bus to control device.</p> <p>Telegrams: 0...100%</p>
	<p>Brightness status group address</p>	<p>1byte type. Input group address for receiving brightness status from other devices on the KNX bus.</p> <p>Telegrams: 0...100%</p>

### 5.12.3.2. Controlling device

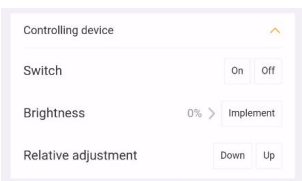
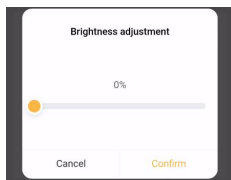
	Switch	There are two control buttons, "On" and "Off", which can be clicked to send the corresponding control commands to the KNX bus or the 485 bus.
	Brightness	Click on the brightness value to pop-up a adjustment window, the adjustable range is 0~100%, after setting, click on "Implement" button to send the brightness value to KNX bus or 485 bus.  
	Relative adjustment	There are two control buttons "Up" and "Down" to adjust the brightness by relative dimming. Long press sends 100% (0%), long release sends stop dimming command; short press sends only dimming to 100% (0%).

### 5.12.3.3. Get device properties

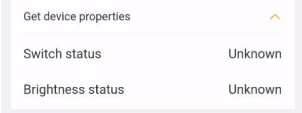
	Switch status	Display the received status, or "Unknown" if not sure.
	Brightness status	Display the received status, or "Unknown" if not sure.

### 5.12.4 Colour temperature lamp

Type of Colour temperature lamp requires device model configuration; it supports access to KNX devices and 485 devices.

#### 5.12.4.1. Device model configuration

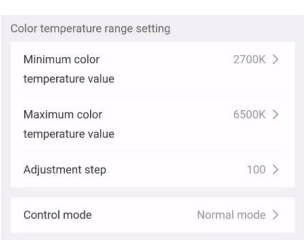
	<p>Minimum color temperature value</p>	<p>Used to set the upper and lower thresholds of color temperature. The minimum value must be less than the maximum value.</p>
	<p>Maximum color temperature value</p>	<p>Optional range is 2000~7000K.</p>
	<p>Adjustment step</p>	<p>Used to set the step value for each adjustment of the color temperature value in the "GVS Smart" APP.  Options: 100/200/500.</p>
	<p>Control mode</p>	<p>Used to set the way of color temperature control, there are 3 options:</p> <p>Normal mode: send value of 1byte brightness and 2 byte colour temperature;</p> <p>Direct mode + color temperature feedback: directly control, it has been built-in conversion algorithm for "Brightness + Colour Temperature", that is two 1byte objects, which is used for output brightness adjustment to control warm white LED and cool white LED. Can accurately communicate with other control panel data.</p> <p>Direct mode + warm and cool color feedback: directly control, it has been built-in conversion algorithm for warm/cool white brightness, that is two 1byte objects, which is used for output brightness adjustment to control warm white LED and cool white LED. Can accurately communicate with other actuator data.</p>

**5.12.4.2.KNX configuration**

<p>Normal mode:</p> <div style="border: 1px solid #ccc; padding: 5px; margin: 5px 0;"> <p>KNX configuration</p> <table style="width: 100%; border-collapse: collapse;"> <tr><td style="width: 80%;">Switch operation group address</td><td style="text-align: right;">0/0/0</td></tr> <tr><td>Switch status group address</td><td style="text-align: right;">0/0/0</td></tr> <tr><td>Brightness adjustment group address</td><td style="text-align: right;">0/0/0</td></tr> <tr><td>Brightness status group address</td><td style="text-align: right;">0/0/0</td></tr> <tr><td>Color temperature adjustment group address</td><td style="text-align: right;">0/0/0</td></tr> <tr><td>Color temperature status group address</td><td style="text-align: right;">0/0/0</td></tr> </table> </div> <p>Direct mode + color temperature feedback:</p> <div style="border: 1px solid #ccc; padding: 5px; margin: 5px 0;"> <p>KNX configuration</p> <table style="width: 100%; border-collapse: collapse;"> <tr><td style="width: 80%;">Switch operation group address</td><td style="text-align: right;">0/0/0</td></tr> <tr><td>Switch status group address</td><td style="text-align: right;">0/0/0</td></tr> <tr><td>Brightness status group address</td><td style="text-align: right;">0/0/0</td></tr> <tr><td>Warm white brightness control group address</td><td style="text-align: right;">0/0/0</td></tr> <tr><td>Color temperature status feedback status group address</td><td style="text-align: right;">0/0/0</td></tr> <tr><td>Cool white brightness control group address</td><td style="text-align: right;">0/0/0</td></tr> </table> </div> <p>Direct mode + warm and cool color feedback:</p> <div style="border: 1px solid #ccc; padding: 5px; margin: 5px 0;"> <p>KNX configuration</p> <table style="width: 100%; border-collapse: collapse;"> <tr><td style="width: 80%;">Switch operation group address</td><td style="text-align: right;">0/0/0</td></tr> <tr><td>Switch status group address</td><td style="text-align: right;">0/0/0</td></tr> <tr><td>Warm white brightness control group address</td><td style="text-align: right;">0/0/0</td></tr> <tr><td>Warm white brightness status group address</td><td style="text-align: right;">0/0/0</td></tr> <tr><td>Cool white brightness control group address</td><td style="text-align: right;">0/0/0</td></tr> <tr><td>Cool white brightness status group address</td><td style="text-align: right;">0/0/0</td></tr> </table> </div>	Switch operation group address	0/0/0	Switch status group address	0/0/0	Brightness adjustment group address	0/0/0	Brightness status group address	0/0/0	Color temperature adjustment group address	0/0/0	Color temperature status group address	0/0/0	Switch operation group address	0/0/0	Switch status group address	0/0/0	Brightness status group address	0/0/0	Warm white brightness control group address	0/0/0	Color temperature status feedback status group address	0/0/0	Cool white brightness control group address	0/0/0	Switch operation group address	0/0/0	Switch status group address	0/0/0	Warm white brightness control group address	0/0/0	Warm white brightness status group address	0/0/0	Cool white brightness control group address	0/0/0	Cool white brightness status group address	0/0/0	<p>Switch operation group address</p>	<p>1bit type. Input group address for sending on / off telegrams to the KNX bus to control device.</p> <p>Telegrams: 1 - Turn on the light, 0 - Turn off the light</p>
	Switch operation group address	0/0/0																																				
	Switch status group address	0/0/0																																				
	Brightness adjustment group address	0/0/0																																				
	Brightness status group address	0/0/0																																				
	Color temperature adjustment group address	0/0/0																																				
	Color temperature status group address	0/0/0																																				
	Switch operation group address	0/0/0																																				
Switch status group address	0/0/0																																					
Brightness status group address	0/0/0																																					
Warm white brightness control group address	0/0/0																																					
Color temperature status feedback status group address	0/0/0																																					
Cool white brightness control group address	0/0/0																																					
Switch operation group address	0/0/0																																					
Switch status group address	0/0/0																																					
Warm white brightness control group address	0/0/0																																					
Warm white brightness status group address	0/0/0																																					
Cool white brightness control group address	0/0/0																																					
Cool white brightness status group address	0/0/0																																					
	<p>Switch status group address</p>	<p>1bit type. Input group address for receiving on / off status from other devices on the KNX bus.</p> <p>Telegrams: 1 - Turn on the light, 0 - Turn off the light</p>																																				
	<p>Brightness adjustment group address</p>	<p>1byte Type. Input group address, when in Normal mode, used for sending dimming telegrams (brightness value) to the KNX bus to control device. Telegrams: 0...100%</p>																																				
	<p>Brightness status group address</p>	<p>1byte type. Input group address, when in Normal mode or Direct mode + color temperature feedback, used for receiving brightness status from other devices on the KNX bus. Telegrams: 0...100%</p>																																				
	<p>Color temperature adjustment group address</p>	<p>2byte Type. Input group address, when in Normal mode, used for sending color temperature telegrams to the KNX bus to control device. Telegrams: 2000...7000 K</p>																																				
	<p>Color temperature status group address</p>	<p>2byte type. Input group address, when in Normal mode or Direct mode + color temperature feedback, used for receiving color temperature status from other devices on the KNX bus.</p> <p>Telegrams: 2000...7000 K</p>																																				
	<p>Warm white brightness control group address</p>	<p>1byte Type. Input group address, when in Direct mode + color temperature feedback or Direct mode + warm and cool color feedback, used for sending warm white brightness dimming telegrams to the KNX bus to control device. Telegrams: 0...100%</p>																																				

	Cool white brightness control group address	1byte Type. Input group address, when in Direct mode + color temperature feedback or Direct mode + warm and cool color feedback, used for sending cool white brightness dimming telegrams to the KNX bus to control device. Telegrams: 0...100%
	Warm white brightness status group address	1byte type. Input group address, when in Direct mode + warm and cool color feedback, used for receiving warm white brightness status from other devices on the KNX bus. Telegrams: 0...100%
	Cool white brightness status group address	1byte type. Input group address, when in direct mode + warm and cool color feedback, used for receiving cool white brightness status from other devices on the KNX bus. Telegrams: 0...100%

### 5.12.4.3. Controlling device

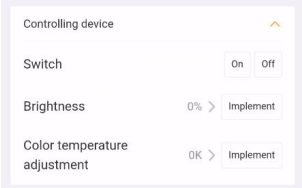
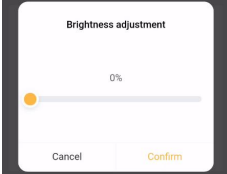
	Switch	There are two control buttons, "On" and "Off", which can be clicked to send the corresponding control commands to the KNX bus or the 485 bus.
	Brightness	Click on the brightness value to pop-up a adjustment window, the adjustable range is 0~100%, after setting, click on "Implement" button to send the value to KNX bus or 485 bus.  

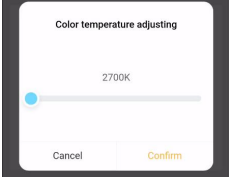
	<p>Color temperature adjustment</p>	<p>Click on the color temperature value to pop-up a adjustment window, the adjustable range depends on the configuration in the device model, after setting, click on "Implement" button to send the value to KNX bus or 485 bus.</p> 
--	-------------------------------------	---

**5.12.4.4. Get device properties**

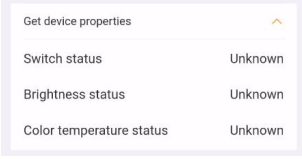
	<p>Switch status</p>	<p>Display the received status, or "Unknown" if not sure.</p>
	<p>Brightness status</p>	<p>Display the received status, or "Unknown" if not sure.</p>
	<p>Color temperature status</p>	<p>Display the received status, or "Unknown" if not sure.</p>

### 5.12.5 RGB

Type of RGB lamp requires device model configuration; it supports access to KNX devices and 485 devices.

#### 5.12.5.1. Device model configuration

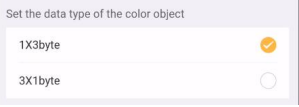
	1x3byte	RGB dimming with one 3 byte object.
	3x1byte	RGB dimming with three 1byte objects.

#### 5.12.5.2. KNX configuration

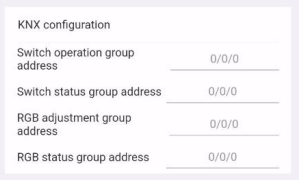
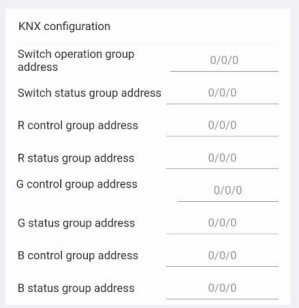
<p><b>1x3byte:</b></p>  <p><b>3x1byte:</b></p> 	Switch operation group address	1bit type. Input group address for sending on / off telegrams to the KNX bus to control device.  Telegrams: 1 - Turn on the light, 0 - Turn off the light
	Switch status group address	1bit type. Input group address for receiving on / off status from other devices on the KNX bus.  Telegrams: 1 - Turn on the light, 0 - Turn off the light
	RGB adjustment group address	3byte type. Input group address for sending brightness value of RGB lamp to the KNX bus to control device.
	RGB status group address	3byte type. Input group address for receiving brightness status of RGB lamp from other devices on the KNX bus.
	R control group address	Three 1byte objects. Input group address for sending individually R/G/B brightness value of lamp to the KNX bus to control device.  Telegrams: 0...100%
	G control group address	
	B control group address	

	R status group address	Three 1byte objects. Input group address for receiving individually R/G/B brightness status from other devices on the KNX bus.  Telegrams: 0...100%
	G status group address	
	B status group address	

### 5.12.5.3. Controlling device

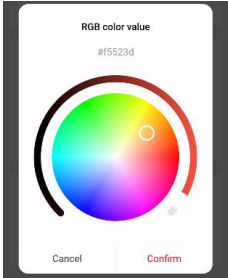
	Switch	There are two control buttons, "On" and "Off", which can be clicked to send the corresponding control commands to the KNX bus or the 485 bus.
	Color	Click on the color temperature value to pop-up a adjustment window, adjust the ring slide bar and the color palette, after setting, click on "Implement" button to send the value to KNX bus or 485 bus.  

### 5.12.5.4. Get device properties

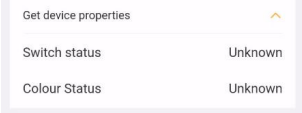
	Switch status	Display the received status, or "Unknown" if not sure.
	Color status	Display the received status, or "Unknown" if not sure.

### 5.12.6 RGBW

Type of RGBW lamp requires device model configuration; it supports access to KNX devices and 485 devices.

#### 5.12.6.1. Device model configuration

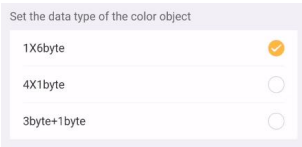
	1x6byte	RGBW dimming with one 6 byte object.
	4x1byte	RGBW dimming with four 1 byte objects.
	3byte+1byte	RGBW dimming with one 3 byte object and one 1byte object.

#### 5.12.6.2. KNX configuration

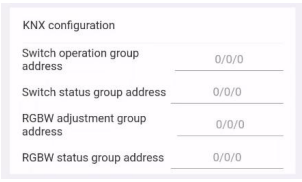
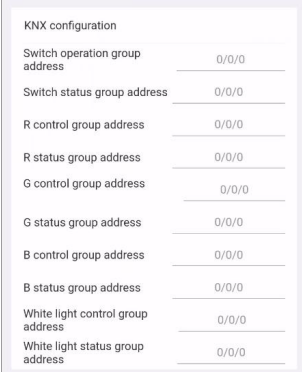
<p><b>1x6byte:</b></p>  <p><b>4x1byte:</b></p> 	Switch operation group address	1bit type. Input group address for sending on / off telegrams to the KNX bus to control device.  Telegrams: 1 - Turn on the light, 0 - Turn off the light
	Switch status group address	1bit type. Input group address for receiving on / off status from other devices on the KNX bus.  Telegrams: 1 - Turn on the light, 0 - Turn off the light
	RGBW adjustment group address	6byte type. Input group address for sending brightness value of RGBW lamp to the KNX bus to control device.
	RGBW status group address	6byte type. Input group address for receiving brightness status of RGBW lamp from other devices on the KNX bus.
	R control group address	Three 1byte objects. Input group address for sending individually R/G/B brightness value of lamp to the KNX bus to control device.
	G control group address	Telegrams: 0...100%

<p><b>3byte+1byte:</b></p> <div style="border: 1px solid #ccc; padding: 5px; margin-bottom: 10px;"> <p>KNX configuration</p> <p>Switch operation group address <input type="text" value="0/0/0"/></p> <p>Switch status group address <input type="text" value="0/0/0"/></p> <p>RGB control group address <input type="text" value="0/0/0"/></p> <p>RGB status group address <input type="text" value="0/0/0"/></p> <p>White light control group address <input type="text" value="0/0/0"/></p> <p>White light status group address <input type="text" value="0/0/0"/></p> </div>	<p>B control group address</p>	
	<p>R status group address</p>	<p>Three 1byte objects. Input group address for receiving individually R/G/B brightness status from other devices on the KNX bus.</p> <p>Telegrams: 0...100%</p>
	<p>G status group address</p>	
	<p>B status group address</p>	
	<p>RGB control group address</p>	<p>3byte type. Input group address for sending brightness value of RGB lamp to the KNX bus to control device.</p>
	<p>RGB status group address</p>	<p>3byte type. Input group address for receiving brightness status of RGB lamp from other devices on the KNX bus.</p>
	<p>White light control group address</p>	<p>1byte type. Input group address for sending white brightness value of lamp to the KNX bus to control device.</p>
	<p>White status control group address</p>	<p>1byte type. Input group address for receiving white brightness status of lamp from other devices on the KNX bus.</p>

### 5.12.6.3. Controlling device

<div style="border: 1px solid #ccc; padding: 5px; margin-bottom: 10px;"> <p>Controlling device <span style="float: right;">⤴</span></p> <p>Switch <span style="float: right;">On Off</span></p> <p>Color #f5523d &gt; Implement</p> <p>Brightness 0% &gt; Implement</p> </div>	<p>Switch</p>	<p>There are two control buttons, "On" and "Off", which can be clicked to send the corresponding control commands to the KNX bus or the 485 bus.</p>
--	---------------	--

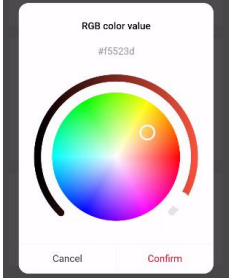
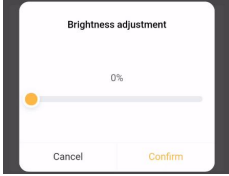
	Color	<p>Click on the color temperature value to pop-up a adjustment window, adjust the ring slide bar and the color palette, after setting, click on "Implement" button to send the value to KNX bus or 485 bus.</p> 
	Brightness	<p>Click on the brightness value to pop-up a adjustment window, the adjustable range is 0~100%, after setting, click on "Implement" button to send the value to KNX bus or 485 bus.</p> 

**5.12.6.4. Get device properties**

	Switch status	Display the received status, or "Unknown" if not sure.
	Color status	Display the received status, or "Unknown" if not sure.
	Brightness status	Display the received status, or "Unknown" if not sure.

### 5.12.7 RGBCW

Type of RGBCW lamp requires device model configuration; it supports access to KNX devices and 485 devices.

#### 5.12.7.1.Device model configuration

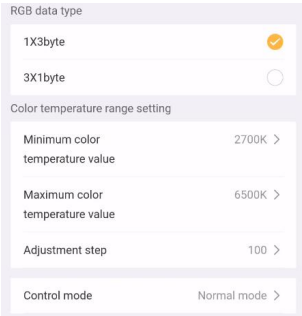
	1x3byte	RGB dimming with one 3 byte object.
	3x1byte	RGB dimming with three 1byte objects.
	Minimum color temperature value	Used to set the upper and lower thresholds of color temperature. The minimum value must be less than the maximum value. Optional range is 2000~7000K.
	Maximum color temperature value	
	Adjustment step	Used to set the step value for each adjustment of the color temperature value in the "GVS Smart" APP. Options: 100/200/500.
	Control mode	Used to set the way of color temperature control, there are 3 options: Normal mode: send value of 1byte brightness and 2 byte colour temperature; Direct mode + color temperature feedback: directly control, it has been built-in conversion algorithm for "Brightness + Colour Temperature", that is two 1byte objects, which is used for output brightness adjustment to control warm white LED and cool white LED. Can accurately communicate with other control panel data.

		<p>Direct mode + warm and cool color feedback: directly control, it has been built-in conversion algorithm for warm/cool white brightness, that is two 1byte objects, which is used for output brightness adjustment to control warm white LED and cool white LED. Can accurately communicate with other actuator data.</p>
--	--	---

### 5.12.7.2.KNX configuration

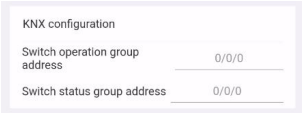
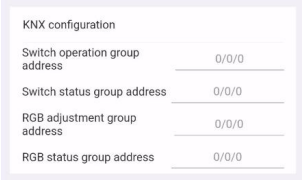
<p><b>Switch:</b></p> 	<p>Switch operation group address</p>	<p>1bit type. Input group address for sending on / off telegrams to the KNX bus to control device.</p> <p>Telegrams: 1 - Turn on the light, 0 - Turn off the light</p>
	<p>Switch status group address</p>	<p>1bit type. Input group address for receiving on / off status from other devices on the KNX bus.</p> <p>Telegrams: 1 - Turn on the light, 0 - Turn off the light</p>
<p><b>RGB-1x3byte:</b></p> 	<p>RGB adjustment group address</p>	<p>3byte type. Input group address for sending brightness value of RGB lamp to the KNX bus to control device.</p>
	<p>RGB status group address</p>	<p>3byte type. Input group address for receiving brightness status of RGB lamp from other devices on the KNX bus.</p>
	<p>R control group address</p>	<p>Three 1byte objects. Input group address for sending individually R/G/B brightness value of lamp to the KNX bus to control device.</p> <p>Telegrams: 0...100%</p>
	<p>G control group address</p>	
<p>B control group address</p>		
<p><b>RGB-3x1byte:</b></p>		

<p>KNX configuration</p> <p>Switch operation group address <u>0/0/0</u></p> <p>Switch status group address <u>0/0/0</u></p> <p>R control group address <u>0/0/0</u></p> <p>R status group address <u>0/0/0</u></p> <p>G control group address <u>0/0/0</u></p> <p>G status group address <u>0/0/0</u></p> <p>B control group address <u>0/0/0</u></p> <p>B status group address <u>0/0/0</u></p>	<p>R status group address</p> <p>G status group address</p> <p>B status group address</p>	<p>Three 1byte objects. Input group address for receiving individually R/G/B brightness status from other devices on the KNX bus.</p> <p>Telegrams: 0...100%</p>
<p><b>CW-Normal mode:</b></p> <p>KNX configuration</p> <p>Switch operation group address <u>0/0/0</u></p> <p>Switch status group address <u>0/0/0</u></p> <p>Brightness adjustment group address <u>0/0/0</u></p> <p>Brightness status group address <u>0/0/0</u></p> <p>Color temperature adjustment group address <u>0/0/0</u></p> <p>Color temperature status group address <u>0/0/0</u></p> <p><b>CW-Direct mode + color temperature feedback:</b></p> <p>KNX configuration</p> <p>Switch operation group address <u>0/0/0</u></p> <p>Switch status group address <u>0/0/0</u></p> <p>Brightness status group address <u>0/0/0</u></p> <p>Warm white brightness control group address <u>0/0/0</u></p> <p>Color temperature status feedback status group address <u>0/0/0</u></p> <p>Cool white brightness control group address <u>0/0/0</u></p> <p><b>CW-Direct mode + warm and cool color feedback:</b></p> <p>KNX configuration</p> <p>Switch operation group address <u>0/0/0</u></p> <p>Switch status group address <u>0/0/0</u></p> <p>Warm white brightness control group address <u>0/0/0</u></p> <p>Warm white brightness status group address <u>0/0/0</u></p> <p>Cool white brightness control group address <u>0/0/0</u></p> <p>Cool white brightness status group address <u>0/0/0</u></p>	<p>Brightness adjustment group address</p> <p>Brightness status group address</p> <p>Color temperature adjustment group address</p> <p>Color temperature status group address</p> <p>Warm white brightness control group address</p> <p>Warm white brightness status group address</p> <p>Cool white brightness control group address</p> <p>Cool white brightness status group address</p>	<p>1byte Type. Input group address, when in Normal mode, used for sending dimming telegrams (brightness value) to the KNX bus to control device. Telegrams: 0...100%</p> <p>1byte type. Input group address, when in Normal mode or Direct mode + color temperature feedback, used for receiving brightness status from other devices on the KNX bus. Telegrams: 0...100%</p> <p>2byte Type. Input group address, when in Normal mode, used for sending color temperature telegrams to the KNX bus to control device. Telegrams: 2000...7000 K</p> <p>2byte type. Input group address, when in Normal mode or Direct mode + color temperature feedback, used for receiving color temperature status from other devices on the KNX bus. Telegrams: 2000...7000 K</p> <p>1byte Type. Input group address, when in Direct mode + color temperature feedback or Direct mode + warm and cool color feedback, used for sending warm white brightness dimming telegrams to the KNX bus to control device. Telegrams: 0...100%</p>

	Cool white brightness control group address	1byte Type. Input group address, when in Direct mode + color temperature feedback or Direct mode + warm and cool color feedback, used for sending cool white brightness dimming telegrams to the KNX bus to control device. Telegrams: 0...100%
	Warm white brightness status group address	1byte type. Input group address, when in Direct mode + warm and cool color feedback, used for receiving warm white brightness status from other devices on the KNX bus. Telegrams: 0...100%
	Cool white brightness status group address	1byte type. Input group address, when in direct mode + warm and cool color feedback, used for receiving cool white brightness status from other devices on the KNX bus. Telegrams: 0...100%

### 5.12.7.3. Controlling device

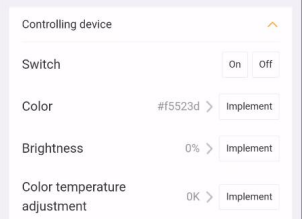
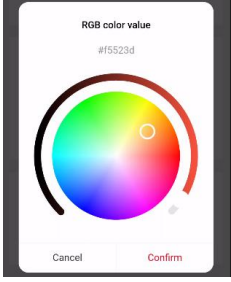
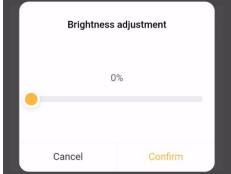
	<p>Switch</p>	<p>There are two control buttons, "On" and "Off", which can be clicked to send the corresponding control commands to the KNX bus or the 485 bus.</p>
	<p>Color</p>	<p>Click on the color temperature value to pop-up a adjustment window, adjust the ring slide bar and the color palette, after setting, click on "Implement" button to send the value to KNX bus or 485 bus.</p> 
	<p>Brightness</p>	<p>Click on the brightness value to pop-up a adjustment window, the adjustable range is 0~100%, after setting, click on "Implement" button to send the brightness value to KNX bus or 485 bus.</p> 
	<p>Color temperature adjustment</p>	<p>Click on the color temperature value to pop-up a adjustment window, the adjustable range depends on the configuration in the device model, after setting, click on "Implement" button to send the value to KNX bus or 485 bus.</p>

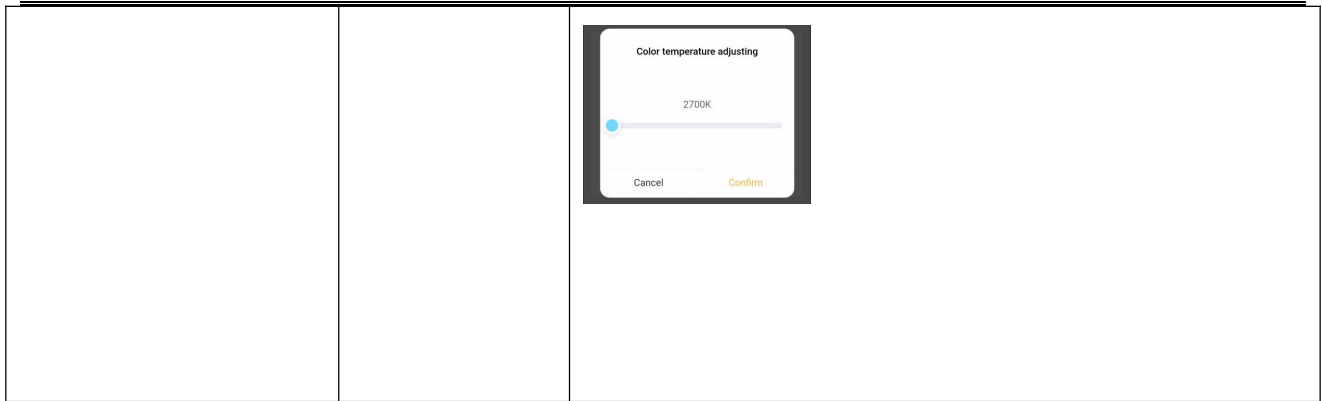

#### 5.12.7.4. Get device properties

	Switch status	Display the received status, or "Unknown" if not sure.
	Color status	Display the received status, or "Unknown" if not sure.
	Brightness status	Display the received status, or "Unknown" if not sure.
	Color temperature status	Display the received status, or "Unknown" if not sure.

### 5.12.8 Curtain position

Type of Curtain position requires device model configuration; it supports access to KNX devices and 485 devices.

#### 5.12.8.1. Device model configuration

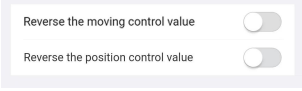
	Reverse the moving control value	Used to set whether to invert the telegram that control the curtain open/close.
	Reverse the position control value	Used to set whether to invert the telegram that control the curtain position.

#### 5.12.8.2. KNX configuration

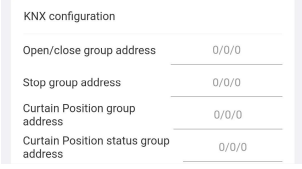
	Open/ Close group address	1bit type. Input group address for sending telegrams to the KNX bus to control curtain open/close.  Telegrams: 1 - Close the curtain, 0 - Open the curtain
	Stop group address	1bit type. Input group address for sending telegrams to the KNX bus to stop curtain movement. Telegrams: 0/1 - Stop
	Curtain position group address	1byte Type. Input group address for sending telegrams to the KNX bus to control the position of the curtain. Telegrams: 0...100%
	Position status group address	1byte type. Input group address for receiving curtain position status from other devices on the KNX bus. Telegrams: 0...100%

### 5.12.8.3. Controlling device

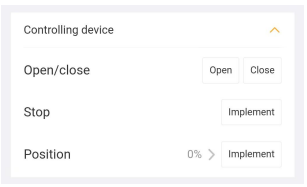
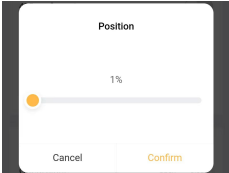
	<p>Open/close</p>	<p>There are two control buttons, "Open" and "Close", which can be clicked to send the corresponding control commands to the KNX bus or the 485 bus.</p>
	<p>Stop</p>	<p>There is one control button, "Implement", which can be clicked to send the corresponding stop command to the KNX bus or the 485 bus.</p>
	<p>Position</p>	<p>Click on the curtain position value to pop-up a adjustment window, the adjustable range is 0~100%, after setting, click on "Implement" button to send the value to KNX bus or 485 bus.</p> 

### 5.12.8.4. Get device properties

	<p>Position</p>	<p>Display the received status, or "Unknown" if not sure.</p>
---	-----------------	---

### 5.12.9 Roller blind position

Type of Roller blind position requires device model configuration; it supports access to KNX devices and 485 devices.

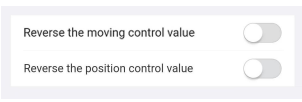

#### 5.12.9.1. Device model configuration

	Reverse the moving control value	Used to set whether to invert the telegram that control the blind up/down.
	Reverse the position control value	Used to set whether to invert the telegram that control the blind position.

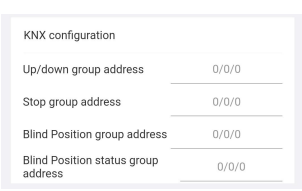
#### 5.12.9.2. KNX configuration

	Up/down group address	1bit type. Input group address for sending telegrams to the KNX bus to control blind up/down.  Telegrams: 1 - Move down, 0 - Move up
	Stop group address	1bit type. Input group address for sending telegrams to the KNX bus to stop blind movement. Telegrams: 0/1 - Stop
	Blind Position group address	1byte Type. Input group address for sending telegrams to the KNX bus to control the position of the blind. Telegrams: 0...100%
	Blind Position status group address	1byte type. Input group address for receiving blind position status from other devices on the KNX bus. Telegrams: 0...100%

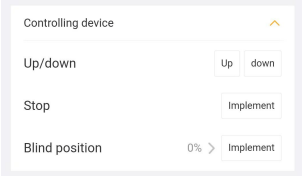
### 5.12.9.3. Controlling device

	Up/down	There are two control buttons, "Up" and "Down", which can be clicked to send the corresponding control commands to the KNX bus or the 485 bus.
	Stop	There is one control button, "Implement", which can be clicked to send the corresponding stop command to the KNX bus or the 485 bus.
	Blind position	Click on the blind position value to pop-up a adjustment window, the adjustable range is 0~100%, after setting, click on "Implement" button to send the value to KNX bus or 485 bus.  

### 5.12.9.4. Get device properties

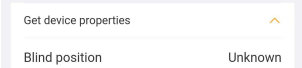
	Blind position	Display the received status, or "Unknown" if not sure.
---	----------------	--

### 5.12.10 Venetian blind position and slat

Type of Venetian blind position and slat requires device model configuration; it supports access to KNX devices and 485 devices.

#### 5.12.10.1. Device model configuration

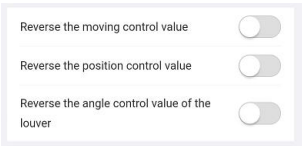

	Reverse the moving control value	Used to set whether to invert the telegram that control the blind up/down.
	Reverse the position control value	Used to set whether to invert the telegram that control the blind position.
	Reverse the angle control value of the louver	Used to set whether to invert the telegram that control the blind angle.

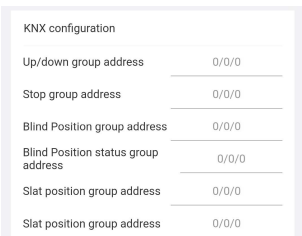
#### 5.12.10.2. KNX configuration

	Up/down group address	1bit type. Input group address for sending telegrams to the KNX bus to control blind up/down.  Telegrams: 1 - Move down, 0 - Move up
	Stop group address	1bit type. Input group address for sending telegrams to the KNX bus to stop blind movement. Telegrams: 0/1 - Stop
	Blind Position group address	1byte Type. Input group address for sending telegrams to the KNX bus to control the position of the blind. Telegrams: 0...100%

	Blind Position status group address	1byte type. Input group address for receiving blind position status from other devices on the KNX bus. Telegrams: 0...100%
	Slat position group address	1byte Type. Input group address for sending telegrams to the KNX bus to control the position of the slat angle. Telegrams: 0...100%
	Slat position status group address	1byte type. Input group address for receiving blind slat status from other devices on the KNX bus. Telegrams: 0...100%

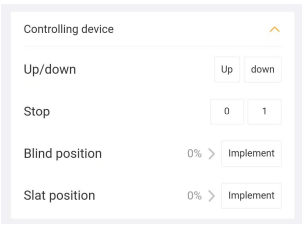
### 5.12.10.3. Controlling device

	Up/down	There are two control buttons, "Up" and "Down", which can be clicked to send the corresponding control commands to the KNX bus or the 485 bus.
	Stop	There is one control button, "Implement", which can be clicked to send the corresponding stop command to the KNX bus or the 485 bus.
	Blind position	Click on the curtain position value to pop-up a adjustment window, the adjustable range is 0~100%, after setting, click on "Implement" button to send the value to KNX bus or 485 bus.  

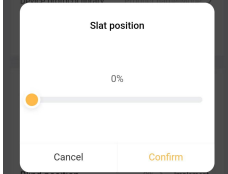
	Slat position	<p>Click on the shutter position value to pop-up a adjustment window, the adjustable range is 0~100%, after setting, click on "Implement" button to send the value to KNX bus or 485 bus.</p> 
--	---------------	---

#### 5.12.10.4. Get device properties

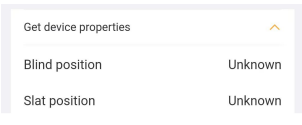
	Blind position	Display the received status, or "Unknown" if not sure.
	Slat position	Display the received status, or "Unknown" if not sure.

#### 5.12.11 Roller blind step/move

Type of Roller blind step/move requires device model configuration; it supports access to KNX devices and 485 devices.

##### 5.12.11.1. Device model configuration

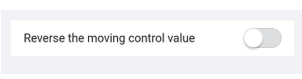
	Reverse the moving control value	Used to set whether to invert the telegram that control the blind up/down.
---	----------------------------------	--

##### 5.12.11.2. KNX configuration

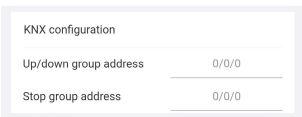
	Up/down group address	<p>1bit type. Input group address for sending telegrams to the KNX bus to control blind up/down.</p> <p>Telegrams: 1 - Move down, 0 - Move up</p>
---	-----------------------	---

	Stop group address	1bit type. Input group address for sending telegrams to the KNX bus to stop blind movement. Telegrams: 0/1 - Stop
--	--------------------	---

### 5.12.11.3. Controlling device

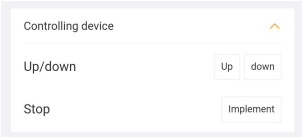
	Up/down	There are two control buttons, "Up" and "Down", which can be clicked to send the corresponding control commands to the KNX bus or the 485 bus.
	Stop	There is one control button, "Implement", which can be clicked to send the corresponding stop command to the KNX bus or the 485 bus.

### 5.12.11.4. Get device properties

There are no device statuses that can be obtained.

### 5.12.12 Curtain step/move

Type of Curtain step/move requires device model configuration; it supports access to KNX devices and 485 devices.

#### 5.12.12.1. Device model configuration

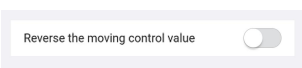
	Reverse the moving control value	Used to set whether to invert the telegram that control the curtain close/close.
---	----------------------------------	--

### 5.12.12.2.KNX configuration

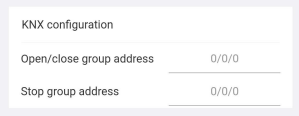
	<p>Open/ close group address</p>	<p>1bit type. Input group address for sending telegrams to the KNX bus to control curtain open/close.</p> <p>Telegrams: 1 - Close the curtain, 0 - Open the curtain</p>
	<p>Stop group address</p>	<p>1bit type. Input group address for sending telegrams to the KNX bus to stop curtain movement. Telegrams: 0/1 - Stop</p>

### 5.12.12.3.Controlling device

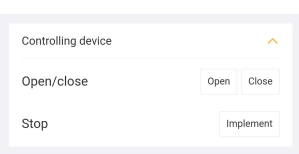
	<p>Open/ close</p>	<p>There are two control buttons, "Open" and "Close", which can be clicked to send the corresponding control commands to the KNX bus or the 485 bus.</p>
	<p>Stop</p>	<p>There is one control button, "Implement", which can be clicked to send the corresponding stop command to the KNX bus or the 485 bus.</p>

### 5.12.12.4.Get device properties

There are no device statuses that can be obtained.

### 5.12.13 HVAC

Type of HVAC requires device model configuration; it supports access to KNX devices and 485 devices. The HVAC system only operates in slave mode, offering solely touch and display functions without temperature control algorithms. Upon device reboot, it will send status read requests for functions such as switch, setpoint temperature, control mode, operation mode, and fan speed.

#### 5.12.13.1.Device model configuration

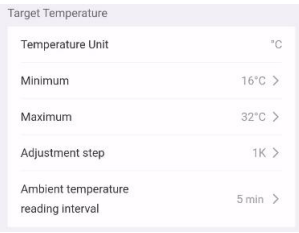
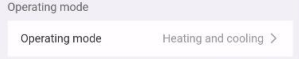
	Switch Enable	Used to set whether to enable the function of power on/off. When not enabled, the power on/off icon on the "GVS Smart" APP will not be displayed.
	Temperature Unit	The temperature unit is fixed at °C.
	Minimum	Used to set the upper and lower thresholds of temperature. The minimum value must be less than the maximum value. Optional range is 5~40°C.
	Maximum	
	Adjustment step	Used to set the step value for each adjustment of the temperature value in the "GVS Smart" APP. Options: 1K/0.5K
	Ambient temperature reading Interval	Used to set time period for read request external temperature sensor. Options: 0~255 minute
	Operation mode	Used to set the RTC control mode. Options: Heating, Cooling, Heating and Cooling.

<p>Fan speed</p> <p>Fan speed data type      percentage &gt;</p> <hr/> <p>Set fan speedControl Value</p> <p>Fan speed off                      0</p> <p>Fan speed low                      1</p> <p>Fan speed low                      2</p> <p>Fan speed high                      3</p> <hr/> <p>Set fan speedStatus value</p> <p>Fan speed off                      0</p> <p>Fan speed low                      1</p> <p>Fan speed low                      2</p> <p>Fan speed high                      3</p> <hr/> <p>Enable fan speed auto.control      <input checked="" type="checkbox"/></p>	<p>Fan speed data type</p> <p>Fan speed off</p> <p>Fan speed low</p> <p>Fan speed medium</p> <p>Fan speed high</p> <p>Enable fan speed auto. control</p>	<p>Used to set the datatype of 1byte fan speed. Options: Fan stage (DPT 5.100), Percentage (DPT 5.001).</p> <p>Used to set the output values and status feedback values for each fan speed switchover, support 4 fan speeds: off, low, medium, high. Options according to wind object datatype: 0..255/0..100</p> <p>Used to set whether to enable fan speed auto function, display corresponding objects when enable.</p>
<p>Operating mode</p> <p>Data type                      1byte</p>	<p>Operation mode</p>	<p>Used to set the object type of operation mode switchover. When it is slave mode, only support the option 1byte.</p> <p>1byte : the object "Operation mode operation group address" and "Operation mode status group address" are visible, the telegrams sent are: "1" for comfort mode, "2" for standby mode, "3" for Economy mode , "4" for protection mode. And the device will be updated to different mode according to the receiving telegram.</p>

**5.12.13.2.KNX configuration**

KNX configuration Switch operation group address 0/0/0 Switch status group address 0/0/0 Control mode operation group address 0/0/0 Control mode status group address 0/0/0 Operating mode operating group address 0/0/0 Operation mode status group address 0/0/0 Fan speed operation group address 0/0/0 Fan speed status group address 0/0/0 Room temperature status group address 0/0/0 Set temperature operation group address 0/0/0 Set temperature status group address 0/0/0 Fan speed auto. operating group address 0/0/0 Fan speed auto. status group address 0/0/0	Switch operation group address	1bit type. Input group address for sending on / off telegrams to the KNX bus to control device.  Telegrams: 1 - Power on, 0 - Power off
	Switch status group address	1bit type. Input group address for receiving on / off status from other devices on the KNX bus.  Telegrams: 1 - Power on, 0 - Power off
	Control mode operation group address	1bit type. Input group address for sending control mode to the KNX bus to control device. Telegrams: 1 - Heating, 0 - Cooling
	Control mode status group address	1bit type. Input group address for receiving status of control mode from other devices on the KNX bus.  Telegrams: 1 - Heating, 0 - Cooling
	Operation mode operation group address	1byte type. Input group address for sending operation mode to the KNX bus to control device.  Telegrams: 1-Comfort, 2-Standby, 3-Economy, 4-Protection, other reserved.
	Operation mode status group address	1byte type. Input group address for receiving status of operation mode from other devices on the KNX bus.  Telegrams: 1-Comfort, 2-Standby, 3-Economy, 4-Protection, other reserved.

Fan speed operation group address	1byte type. Input group address, activate the corresponding fan speed on APP for sending fan speed value to the KNX bus to control device. The corresponding telegram value of each fan speed is defined by the parameter.
Fan speed status group address	1byte type. Input group address for receiving specified value from other devices on the KNX bus, the display status of fan speed on APP is updated to the corresponding fan speed.
Room temperature status group address	2byte type. Input group address for receiving the temperature value detected by the temperature sensor from other devices on the KNX bus.
Set temperature operation group address	2byte type. Input group address for sending current setpoint temperature to the KNX bus.
Set temperature status group address	2byte type. Input group address for receiving the status of current setpoint temperature from other devices on the KNX bus.
Fan speed auto. operation group address	1bit type. Input group address for sending telegrams of auto fan speed to the KNX bus to control device.  Telegrams: 1 - Automatic, 0 - Cancel automatic
Fan speed auto. status group address	1bit type. Input group address for receiving status of auto fan speed from other devices on the KNX bus.  Telegrams: 1 - Automatic, 0 - Cancel automatic

### 5.12.13.3. Controlling device

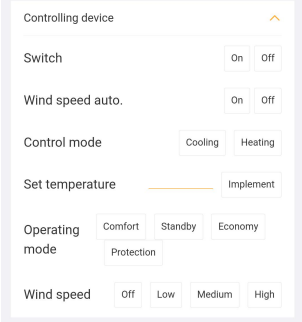
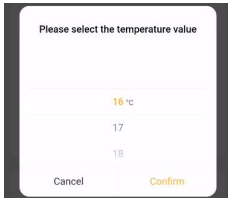
	Switch	There are two control buttons, "On" and "Off", which can be clicked to send the corresponding control commands to the KNX bus or the 485 bus.
	Fan speed auto.	There are two control buttons, "On" and "Off", which can be clicked to send the corresponding control commands of auto fan speed to the KNX bus or the 485 bus.
	Control mode	There are two control buttons, "Cooling" and "Heating", which can be clicked to send the corresponding control commands to the KNX bus or the 485 bus.
	Set temperature	Click on the temperature value to pop-up a adjustment window, after setting, click on "Implement" button to send the value to KNX bus or 485 bus.  
	Operation mode	There are four control buttons, "Comfort", "Standby", "Economy", and "Protection", which can be clicked to send the corresponding control commands to the KNX bus or the 485 bus.
	Fan speed	There are four control buttons, "Off", "Low", "Medium", and "High", which can be clicked to send the corresponding control commands to the KNX bus or the 485 bus.

#### 5.12.13.4. Get device properties

<div style="border: 1px solid #ccc; padding: 5px;"> <p>Get device properties <span style="float: right;">^</span></p> <p>Switch status <span style="float: right;">Unknown</span></p> <p>Control mode <span style="float: right;">Unknown</span></p> <p>Operating mode <span style="float: right;">Unknown</span></p> <p>Fan speed auto. <span style="float: right;">Unknown</span></p> <p>Fan speed <span style="float: right;">Unknown</span></p> <p>Set temperature <span style="float: right;">Unknown</span></p> <p>Real-time temperature <span style="float: right;">Unknown</span></p> </div>	Switch status	Display the received status, or "Unknown" if not sure.
	Control mode	Display the received status, or "Unknown" if not sure.
	Operation mode	Display the received status, or "Unknown" if not sure.
	Fan speed auto.	Display the received status, or "Unknown" if not sure.
	Fan speed	Display the received status, or "Unknown" if not sure.
	Set temperature	Display the received status, or "Unknown" if not sure.
	Real-time temperature	Display the received status, or "Unknown" if not sure.

### 5.12.14 Air conditioner

Type of Air conditioner lamp requires device model configuration; it supports access to KNX devices and 485 devices.

#### 5.12.14.1.Device model configuration

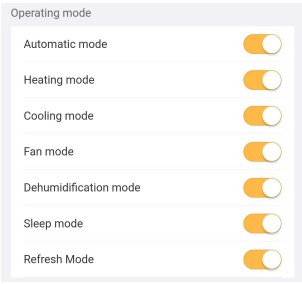
	Temperature Unit	The temperature unit is fixed at °C.
	Minimum	Used to set the upper and lower thresholds of temperature. The minimum value must be less than the maximum value. Optional range is 5~40°C.
	Maximum	
	Adjustment step	Used to set the step value for each adjustment of the temperature value in the "GVS Smart" APP. Options: 1K/0.5K
	Automatic mode	Used to enable each operation mode.
	Heating mode	
	Cooling mode	
	Fan mode	
	Dehumidification mode	
	Sleep mode	
	Refresh mode	



<p>Operating mode control value</p> <table border="1"> <tr><td>Automatic mode</td><td>1</td></tr> <tr><td>Heating mode</td><td>2</td></tr> <tr><td>Cooling mode</td><td>3</td></tr> <tr><td>Fan mode</td><td>4</td></tr> <tr><td>Dehumidification mode</td><td>5</td></tr> <tr><td>Sleep mode</td><td>6</td></tr> <tr><td>Refresh Mode</td><td>7</td></tr> </table> <p>Operating mode status value</p> <table border="1"> <tr><td>Automatic mode</td><td>1</td></tr> <tr><td>Heating mode</td><td>2</td></tr> <tr><td>Cooling mode</td><td>3</td></tr> <tr><td>Fan mode</td><td>4</td></tr> <tr><td>Dehumidification mode</td><td>5</td></tr> <tr><td>Sleep mode</td><td>6</td></tr> <tr><td>Refresh Mode</td><td>7</td></tr> </table>	Automatic mode	1	Heating mode	2	Cooling mode	3	Fan mode	4	Dehumidification mode	5	Sleep mode	6	Refresh Mode	7	Automatic mode	1	Heating mode	2	Cooling mode	3	Fan mode	4	Dehumidification mode	5	Sleep mode	6	Refresh Mode	7	<p>Automatic mode</p> <p>Heating mode</p> <p>Cooling mode</p> <p>Fan mode</p> <p>Dehumidification mode</p> <p>Sleep mode</p> <p>Refresh mode</p>	<p>Used to set the output values and status feedback values for each operation mode switchover. The device will update the icon status of operation mode according to the received feedback value.</p> <p>Options: 0~255.</p>
Automatic mode	1																													
Heating mode	2																													
Cooling mode	3																													
Fan mode	4																													
Dehumidification mode	5																													
Sleep mode	6																													
Refresh Mode	7																													
Automatic mode	1																													
Heating mode	2																													
Cooling mode	3																													
Fan mode	4																													
Dehumidification mode	5																													
Sleep mode	6																													
Refresh Mode	7																													
<p>Fan speed</p> <p>Fan speed data type <span>percentage &gt;</span></p> <p>Set fan speedControl Value</p> <table border="1"> <tr><td>Low</td><td>3</td></tr> <tr><td>Medium</td><td>5</td></tr> <tr><td>High</td><td>8</td></tr> <tr><td>Auto</td><td>10</td></tr> </table> <p>Set fan speedStatus value</p> <table border="1"> <tr><td>Low</td><td>3</td></tr> <tr><td>Medium</td><td>5</td></tr> <tr><td>High</td><td>8</td></tr> <tr><td>Auto</td><td>10</td></tr> </table> <p>Wind direction enable <input checked="" type="checkbox"/></p>	Low	3	Medium	5	High	8	Auto	10	Low	3	Medium	5	High	8	Auto	10	<p>Fan speed data type</p> <p>Low</p> <p>Medium</p> <p>High</p> <p>Auto</p> <p>Wind direction enable</p>	<p>Used to set the datatype of 1byte fan speed. Options: Fan stage (DPT 5.100), Percentage (DPT 5.001).</p> <p>Used to set the output values and status feedback values for each fan speed switchover, support 4 fan speeds: low, medium, high, auto. Options according to wind object datatype: 0..255/0..100</p> <p>Used to set whether to enable the function of wind direction, display corresponding objects when enable.</p>												
Low	3																													
Medium	5																													
High	8																													
Auto	10																													
Low	3																													
Medium	5																													
High	8																													
Auto	10																													

**5.12.14.2.KNX configuration**

<div style="border: 1px solid #ccc; padding: 5px;"> <p>KNX configuration</p> <p>Switch operation group address <span style="float: right;">0/0/0</span></p> <hr/> <p>Switch status group address <span style="float: right;">0/0/0</span></p> <hr/> <p>Fan speed operation group address <span style="float: right;">0/0/0</span></p> <hr/> <p>Fan speed status group address <span style="float: right;">0/0/0</span></p> <hr/> <p>Room temperature status group address <span style="float: right;">0/0/0</span></p> <hr/> <p>Set temperature operation group address <span style="float: right;">0/0/0</span></p> <hr/> <p>Set temperature status group address <span style="float: right;">0/0/0</span></p> <hr/> <p>Operating mode operating group address <span style="float: right;">0/0/0</span></p> <hr/> <p>Operating mode status group address <span style="float: right;">0/0/0</span></p> <hr/> <p>Wind direction operation group address <span style="float: right;">0/0/0</span></p> <hr/> <p>Wind direction status group address <span style="float: right;">0/0/0</span></p> </div>	<p><b>Switch operation group address</b></p>	<p>1bit type. Input group address for sending on / off telegrams to the KNX bus to control device.</p> <p>Telegrams: 1 - Power on, 0 - Power off</p>
	<p><b>Switch status group address</b></p>	<p>1bit type. Input group address for receiving on / off status from other devices on the KNX bus.</p> <p>Telegrams: 1 - Power on, 0 - Power off</p>
	<p><b>Fan speed operation group address</b></p>	<p>1byte type. Input group address, activate the corresponding fan speed on APP for sending fan speed value to the KNX bus to control device. The corresponding telegram value of each fan speed is defined by the parameter.</p>
	<p><b>Fan speed status group address</b></p>	<p>1byte type. Input group address for receiving specified value from other devices on the KNX bus, the display status of fan speed on APP is updated to the corresponding fan speed.</p>
	<p><b>Room temperature status group address</b></p>	<p>2byte type. Input group address for receiving the temperature value detected by the temperature sensor from other devices on the KNX bus.</p>
	<p><b>Set temperature operation group address</b></p>	<p>2byte type. Input group address for sending current setpoint temperature to the KNX bus.</p>

	Set temperature status group address	2byte type. Input group address for receiving the status of current setpoint temperature from other devices on the KNX bus.
	Operation mode operation group address	1byte type. Input group address for sending operation mode to the KNX bus to control device. The corresponding telegram value of each mode is defined by the parameter.
	Operation mode status group address	1byte type. Input group address for receiving status of operation mode from other devices on the KNX bus. The corresponding telegram value of each mode is defined by the parameter.
	Wind direction operation group address	1bit type. Input group address for sending the telegrams of wind direction to the KNX bus to control device.  Telegrams: 1 - Swing, 0 - Fixed
	Wind direction status group address	1bit type. Input group address for receiving the status of wind direction from other devices on the KNX bus.  Telegrams: 1 - Swing, 0 - Fixed

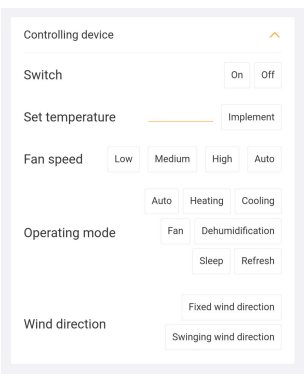
### 5.12.14.3. Controlling device

	<p>Switch</p>	<p>There are two control buttons, "On" and "Off", which can be clicked to send the corresponding control commands to the KNX bus or the 485 bus.</p>
	<p>Set temperature</p>	<p>Click on the temperature value to pop-up a adjustment window, after setting, click on "Implement" button to send the value to KNX bus or 485 bus.</p> 
	<p>Fan speed</p>	<p>There are four control buttons, "Low", "Medium", "High" and "Auto", which can be clicked to send the corresponding control commands to the KNX bus or the 485 bus.</p>
	<p>Operation mode</p>	<p>There are multiple control buttons, "Auto", "Heating", "Cooling", "Fan", "Dehumidification", "Sleep", and "Refresh", which can be clicked to send the corresponding control commands to the KNX bus or the 485 bus.</p>
	<p>Wind direction</p>	<p>There are two control buttons, "Fixed wind direction" and "Swinging wind direction", which can be clicked to send the corresponding control commands to the KNX bus or the 485 bus.</p>

#### 5.12.14.4. Get device properties



<div style="border: 1px solid #ccc; padding: 5px;"> <p>Get device properties <span style="float: right;">^</span></p> <p>Switch status      Unknown</p> <p>Operating mode      Unknown</p> <p>Fan speed      Unknown</p> <p>Wind direction      Unknown</p> <p>Set temperature      Unknown</p> <p>Real-time temperature      Unknown</p> </div>	Switch status	Display the received status, or "Unknown" if not sure.
	Operation mode	Display the received status, or "Unknown" if not sure.
	Fan speed	Display the received status, or "Unknown" if not sure.
	Wind direction	Display the received status, or "Unknown" if not sure.
	Set temperature	Display the received status, or "Unknown" if not sure.
	Real-time temperature	Display the received status, or "Unknown" if not sure.

### 5.12.15 Floor heating

Type of Floor heating requires device model configuration; it supports access to KNX devices and 485 devices.

The floor heating system only operates in slave mode, offering solely touch and display functions without temperature control algorithms. Upon device reboot, it will send status read requests for functions such as switch, setpoint temperature.

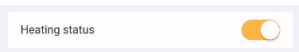

#### 5.12.15.1.Device model configuration

	Switch	Used to set whether to enable the function of power on/off. When not enabled, the power on/off icon on the "GVS Smart" APP will not be displayed.
	Temperature Unit	The temperature unit is fixed at °C.
	Minimum	Used to set the upper and lower thresholds of temperature. The minimum value must be less than the maximum value. Optional range is 5~40°C.
	Maximum	
	Adjustment step	Used to set the step value for each adjustment of the temperature value in the "GVS Smart" APP. Options: 1K/0.5K
	Ambient temperature reading Interval	Used to set time period for read request external temperature sensor. Options: 0~255 minute
	Heating status	Used to set whether to receive heating status. When not enabled, the heating icon on the "GVS Smart" APP will not be displayed.

### 5.12.15.2.KNX configuration

<p>KNX configuration</p> <p>Switch operation group address <input type="text" value="0/0/0"/></p> <p>Switch status group address <input type="text" value="0/0/0"/></p> <p>Set temperature operation group address <input type="text" value="0/0/0"/></p> <p>Set temperature status group address <input type="text" value="0/0/0"/></p> <p>Room temperature status group address <input type="text" value="0/0/0"/></p> <p>Heating status group address <input type="text" value="0/0/0"/></p>	<p>Switch operation group address</p>	<p>1bit type. Input group address for sending on / off telegrams to the KNX bus to control device.</p> <p>Telegrams: 1 - Power on, 0 - Power off</p>
	<p>Switch status group address</p>	<p>1bit type. Input group address for receiving on / off status from other devices on the KNX bus.</p> <p>Telegrams: 1 - Power on, 0 - Power off</p>
	<p>Set temperature operation group address</p>	<p>2byte type. Input group address for sending current setpoint temperature to the KNX bus.</p>
	<p>Set temperature status group address</p>	<p>2byte type. Input group address for receiving the status of current setpoint temperature from other devices on the KNX bus.</p>
	<p>Room temperature status group address</p>	<p>2byte type. Input group address for receiving the temperature value detected by the temperature sensor from other devices on the KNX bus.</p>
	<p>Heating status group address</p>	<p>1bit type. Input group address for receiving heating status from other devices on the KNX bus.</p> <p>Telegrams: 1 - Heating, 0 - Stop heating</p>

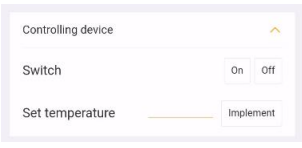
### 5.12.15.3. Controlling device

	Switch	There are two control buttons, "On" and "Off", which can be clicked to send the corresponding control commands to the KNX bus or the 485 bus.
	Set temperature	Click on the temperature value to pop-up a adjustment window, after setting, click on "Implement" button to send the value to KNX bus or 485 bus.  

### 5.12.15.4. Get device properties

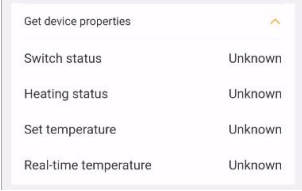
	Switch status	Display the received status, or "Unknown" if not sure.
	Heating status	Display the received status, or "Unknown" if not sure.
	Set temperature	Display the received status, or "Unknown" if not sure.
	Real-time temperature	Display the received status, or "Unknown" if not sure.

### 5.12.16 Central Ventilation system

Type of Central Ventilation system requires device model configuration; it supports access to KNX devices and 485 devices.

#### 5.12.16.1.Device model configuration

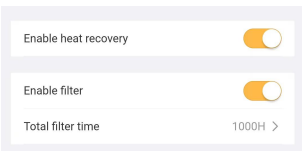
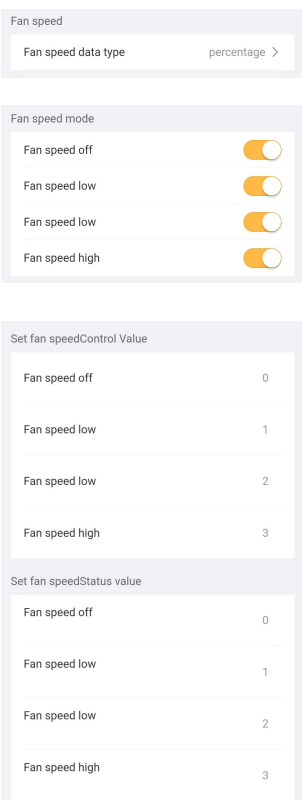
	Enable heat recovery	Used to set whether to enable the function of heat recovery. When not enabled, the function can not be controlled.
	Enable filter	Used to set whether to enable the function of filter timer.
	Total filter time	Previous item is enabled, this setting is valid. Used to set the service life of the filter, optional range is 0~9999H. If the filter takes longer than the setting time, the filter will send an alarm and prompt to clean the filter.
	Fan speed data type	Used to set the datatype of 1byte fan speed. Options: Fan stage type (DPT 5.100), Percentage (DPT 5.001).
	Fan speed mode	Used to set whether enable each fan speed. When enabled, following fan speed settings are valid.  <i>Note: the auto function is only available when 2 or more fan speed levels are enabled, otherwise it is not available.</i>
	Fan speed off	Used to set the output values and status feedback values for each fan speed switchover, support 4 fan speeds: off, low, medium, high.  Options according to wind object datatype: 0..255/0..100
	Fan speed low	
	Fan speed medium	
	Fan speed high	

<p>Operating mode</p> <ul style="list-style-type: none"> <li>Automatic <input checked="" type="checkbox"/></li> <li>Ventilation <input checked="" type="checkbox"/></li> <li>Exhaust <input checked="" type="checkbox"/></li> <li>Intelligent <input checked="" type="checkbox"/></li> <li>Powerful <input checked="" type="checkbox"/></li> <li>Power-saving <input checked="" type="checkbox"/></li> <li>Heat recovery <input checked="" type="checkbox"/></li> <li>Internal circulation <input checked="" type="checkbox"/></li> <li>External circulation <input checked="" type="checkbox"/></li> <li>Disinfection <input checked="" type="checkbox"/></li> <li>Total exhaust <input checked="" type="checkbox"/></li> <li>Bypass <input checked="" type="checkbox"/></li> </ul>	<ul style="list-style-type: none"> <li>Automatic</li> <li>Ventilation</li> <li>Exhaust</li> <li>Intelligent</li> <li>Powerful</li> <li>Power-saving</li> <li>Heat recovery</li> <li>Internal circulation</li> <li>External circulation</li> <li>Disinfection</li> <li>Total exhaust</li> <li>Bypass</li> </ul>	<p>Used to enable each operation mode.</p>
<p>Operating mode control value</p> <ul style="list-style-type: none"> <li>Automatic 0</li> <li>Ventilation 1</li> <li>Exhaust 2</li> <li>Intelligent 3</li> <li>Powerful 4</li> <li>Power-saving 5</li> <li>Heat recovery 6</li> <li>Internal circulation 7</li> <li>External circulation 8</li> <li>Disinfection 9</li> <li>Total exhaust 10</li> <li>Bypass 11</li> </ul>	<ul style="list-style-type: none"> <li>Automatic</li> <li>Ventilation</li> <li>Exhaust</li> <li>Intelligent</li> <li>Powerful</li> <li>Power-saving</li> <li>Heat recovery</li> <li>Internal circulation</li> <li>External circulation</li> <li>Disinfection</li> <li>Total exhaust</li> <li>Bypass</li> </ul>	<p>Used to set the output values and status feedback values for each operation mode switchover. The device will update the icon status of operation mode according to the received feedback value.</p> <p>Options: 0~255.</p>

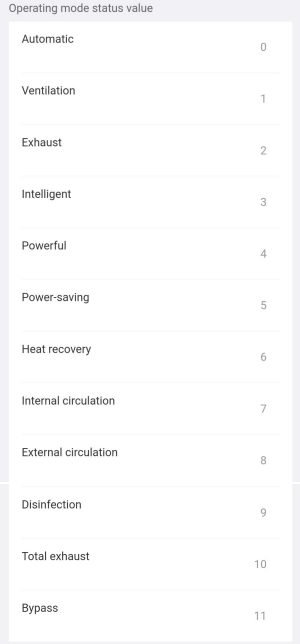
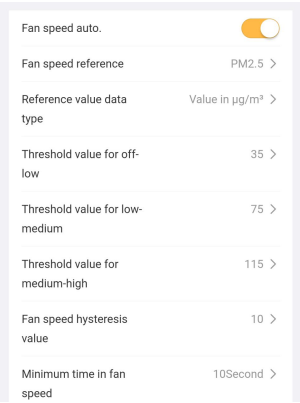
		
	<p>Fan speed auto.</p>	<p>Used to set whether to enable fan speed auto function. When enabled, following auto settings are valid.</p> <p>The fan speed can be linked with the PM2.5 or CO2 detection value, and the sensor data can be obtained from the KNX bus. The telegrams of auto fan speed is 1-enable, 0-disable.</p> <p>After the device is powered on or programmed, automatic operation is not enabled by default. Power off and manually adjust the fan speed can exit the automatic operation.</p>
	<p>Fan speed reference</p>	<p>Used to set the reference value, options: PM2.5、CO2</p>

	Reference value data type	Used to set the datatype of PM2.5/CO2, select it according to the docking sensor.  PM2.5, options:  Value in ug/m3(DPT_7.001), Float value in ug/m3(DPT_9.030)  CO2, options:  Value in ppm(DPT_7.001), Float value in ppm(DPT_9.008)
	Threshold value for off-low	Define threshold value for speed OFF<-->low,  options: 1~999/100~4000  If the control value is greater than or equal to this setting threshold value, start to run low fan speed; if the control value is less than this setting threshold value, the fan will be turned off.
	Threshold value for low-medium	Define the threshold value for speed low<-->medium, if the control value is greater than or equal to this setting threshold, start to run medium fan speed. Options: 1~999/100~4000
	Threshold value for medium-high	Define the threshold for speed medium<-->high, if the control value is greater than or equal to this setting threshold, start to run high fan speed. Options: 1~999/100~4000

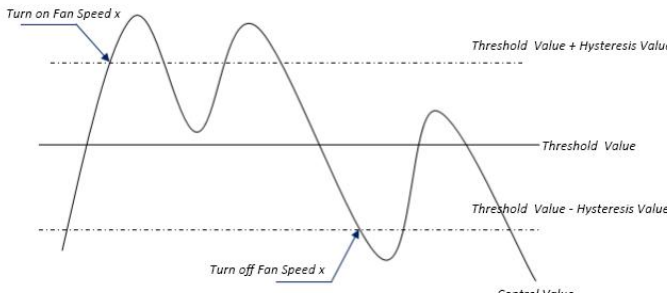
	<p>Fan speed hysteresis value</p>	<p>Used to set the hysteresis value of the threshold value, which can avoid the unnecessary action of the fan when the control value fluctuates near the threshold. Options: 10~30/100~400</p> <p>For example, the control type is PM2.5, the Hysteresis value is 10 and the threshold is 35, then the upper limit threshold 45 (Threshold value+Hysteresis value) and the lower limit threshold 25 (Threshold value-Hysteresis value). When the control value is between 25~45, fan action will not be caused, and the previous status will still be maintained.</p> <p>Only less than 25 or greater than or equal to 45 will change the running status of the fan. As shown in the following figure:</p> 
	<p>Minimum time in fan speed</p>	<p>Defines the residence time of the fan from the current fan speed to a higher fan speed or lower fan speed, that is, the minimum time for a fan speed operation. Optional range is 0~65535 second, 0 is no minimum running time.</p> <p>If you need to switch to another fan speed, you need to wait for this period of time before switching.</p> <p>If the current fan speed has been running long enough, the fan speed can be changed quickly.</p>

**Note:**

When hysteresis is enabled, if the threshold overlap occurs, fan action is specified as follows:

- 1) Hysteresis determines the control point where Fan speed conversion occurs;
- 2) If Fan speed conversion occurs, new fan speed is determined by control value and threshold

value, irrespective of hysteresis.

For example (1):

Take PM2.5 as an example

OFF <-> Low fan speed threshold value is 35

Low fan speed <->Medium fan speed threshold value is 55

Medium fan speed <-> High fan speed threshold value is 75

Hysteresis value is 25

The fan speed of the fan turbine increases from OFF:

Fan OFF status will change at a control value of 60 ( $\geq 25+35$ ), and new fan speed will be the mid-fan speed (because 60 is between 55 and 75, irrespective of hysteresis at this time), so the low fan speed is ignored;

The behavior of fan speed when descending from a high fan speed:

The high fan speed will change at a control value of 50 ( $< 75-25$ ), and new fan speed will be low fan speed (because 50 is between 35 and 55, irrespective of hysteresis), so the fan speed is ignored.

For example(2):

Take PM2.5 as an example

OFF <-> Low fan speed threshold value is 20

Low fan speed <->Medium fan speed threshold value is 40

Medium fan speed <-> High fan speed threshold value is 70

Hysteresis value is 10

When fan speed is increasing from OFF:

The OFF status will be turned when the control value is 30 ( $\geq 20+10$ )

When the control value 41 is received, the new speed will be at medium(because the hysteresis is

ignored when the value 41 is between 40 and 70), therefore the low speed is ignored.

When the control value 39 is received, the new speed will be at low (because the hysteresis is ignored when the value 39 is between 20 and 40)

When Fan Speed decreasing from high:

The high speed will be turned when the control value is 60 (<70-10)

When the control value 39 is received, the new speed will be at low(because the hysteresis is ignored when the value 39 is between 20 and 40),therefore the medium speed is ignored.

3) When the control value is 0,the fan will be off at any circumstances.

### 5.12.16.2.KNX configuration

<p>KNX configuration</p> <p>Switch operation group address 0/0/0</p> <p>Switch status group address 0/0/0</p> <p>Heat recovery switching group address 0/0/0</p> <p>Heat recovery status group address 0/0/0</p> <p>Filter reset operation group address 0/0/0</p> <p>Filter alarm 0/0/0</p> <p>Fan speed operation group address 0/0/0</p> <p>Fan speed status group address 0/0/0</p> <p>Fan speed auto. operating group address 0/0/0</p> <p>Fan speed auto. status group address 0/0/0</p> <p>PM2.5 value status group address 0/0/0</p> <p>Filter usage time 0/0/0</p> <p>Operating mode operating group address 0/0/0</p> <p>Operation mode status group address 0/0/0</p>	<p>Switch operation group address</p>	<p>1bit type. Input group address for sending on / off telegrams to the KNX bus to control device.</p> <p>Telegrams: 1 - Power on, 0 - Power off</p>
	<p>Switch status group address</p>	<p>1bit type. Input group address for receiving on / off status from other devices on the KNX bus.</p> <p>Telegrams: 1 - Power on, 0 - Power off</p>
	<p>Heat recovery group address</p>	<p>1bit type. Input group address for sending on / off telegrams of heat recovery to the KNX bus to control device.</p> <p>Telegrams: 1 - On, 0 - Off</p>
	<p>Heat recovery status group address</p>	<p>1bit type. Input group address for receiving the status of heat recovery from other devices on the KNX bus.</p> <p>Telegrams: 1 - On, 0 - Off</p>
	<p>Filter reset operation group address</p>	<p>1bit type. Input group address for reset filter time, and after the filter is reset, the filter time is used to start counting again.</p> <p>Telegrams: 1 - Reset</p>

	Filter alarm	<p>1bit type. Input group address for sending an alarm to remind the user to replace the filter, when use time exceeds the setting value.</p> <p>Telegrams: 1 - Alarm</p>
	Fan speed operation group address	<p>1byte type. Input group address, activate the corresponding fan speed on APP for sending fan speed value to the KNX bus to control device. The corresponding telegram value of each fan speed is defined by the parameter.</p>
	Fan speed status group address	<p>1byte type. Input group address for receiving specified value from other devices on the KNX bus, the display status of fan speed on APP is updated to the corresponding fan speed.</p>
	Fan speed auto. operation group address	<p>1bit type. Input group address for sending telegrams of auto fan speed to the KNX bus to control device.</p> <p>Telegrams: 1 - Automatic, 0 - Cancel automatic</p>
	Fan speed auto. status group address	<p>1bit type. Input group address for receiving status of auto fan speed from other devices on the KNX bus.</p> <p>Telegrams: 1 - Automatic, 0 - Cancel automatic</p>
	PM2.5 value status group address	<p>2byte type. Input group address for receiving the PM2.5 value detected by the sensor from other devices on the KNX bus, and can be updated to the display. The telegram value is defined by the object datatype.</p>
	CO2 value status group address	<p>2byte type. Input group address for receiving the CO2 value detected by the sensor from other devices on the KNX bus, and can be updated to the display. The telegram value is defined by the object datatype.</p>

	Filter usage time	2byte type. Input group address for counting the use time of the filter. When the count value changes, it can be sent to the bus, and the time can also be modified by the bus. The unit of filter time counter is in hours.
	Operation mode operation group address	1byte type. Input group address for sending operation mode to the KNX bus to control device. The corresponding telegram value of each mode is defined by the parameter.
	Operation mode status group address	1byte type. Input group address for receiving status of operation mode from other devices on the KNX bus. The corresponding telegram value of each mode is defined by the parameter.

### 5.12.16.3. Controlling device

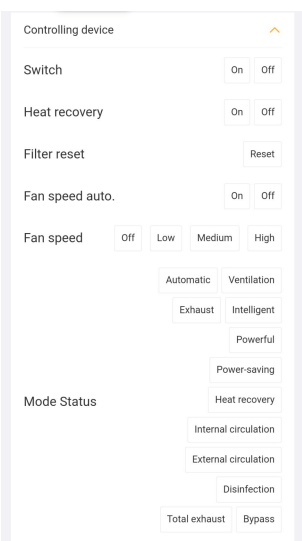
	Switch	There are two control buttons, "On" and "Off", which can be clicked to send the corresponding control commands to the KNX bus or the 485 bus
	Heat recovery	There are two control buttons, "On" and "Off", which can be clicked to send the corresponding control commands to the KNX bus or the 485 bus
	Filter reset	There is one control button, "Reset", which can be clicked to send the command to reset filter time, and after the filter is reset, the filter time is used to start counting again.
	Fan speed auto.	There are two control buttons, "On" and "Off", which can be clicked to send the corresponding control commands to the KNX bus or the 485 bus

	Fan speed	There are four control buttons, "Off", "Low", "Medium", and "High", which can be clicked to send the corresponding control commands to the KNX bus or the 485 bus.
	Mode status	There are multiple control buttons, "Automatic", "Ventilation", "Exhaust", "Intelligent", "Powerful", "Power-saving", "Heat recovery" "Internal circulation" and more, which can be clicked to send the corresponding control commands to the KNX bus or the 485 bus.

#### 5.12.16.4. Get device properties

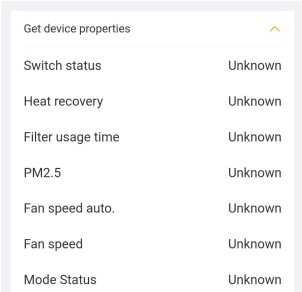
	Switch status	Display the received status, or "Unknown" if not sure.
	Heat recovery	Display the received status, or "Unknown" if not sure.
	Filter usage time	Display the received status, or "Unknown" if not sure.
	PM2.5	Display the received status, or "Unknown" if not sure.
	CO2	Display the received status, or "Unknown" if not sure.
	Fan speed auto.	Display the received status, or "Unknown" if not sure.
	Fan speed	Display the received status, or "Unknown" if not sure.
	Mode status	Display the received status, or "Unknown" if not sure.

### 5.12.17 Background music

Type of Background music requires device model configuration; it supports access to KNX devices and 485 devices.

#### 5.12.17.1.Device model configuration

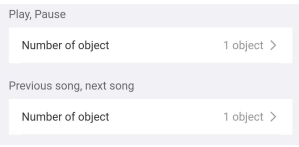
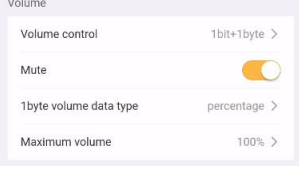
	Switch Enable	Used to set whether to enable the function of power on/off. When not enabled, the power on/off icon on the "GVS Smart" APP will not be displayed.
	Play, Pause	Used to set the number of objects that control play/pause, 1 common object or 2 separate objects.  Options: One object, Two objects
	Previous song, next song	Used to set the number of objects that control next/previous song, 1 common object or 2 separate objects.  Options: One object, Two objects
	Volume control	Used to set the datatype of volume adjustment.  Options: 1bit、 1bit+1byte。  When 1 bit, support to increase/decrease volume and mute function; When 1 byte, only support 1byte object to adjust volume, and you can set the maximum volume.
	Mute	Used to set whether enable mute function
	1byte volume data type	Visible when "1bit+1byte" is selected. Set the datatype of 1byte object. Options:e percent, percent_255
	Maximum volume	Visible when "1bit+1byte" is selected. Set the the maximum volume value. Options: 10..100%

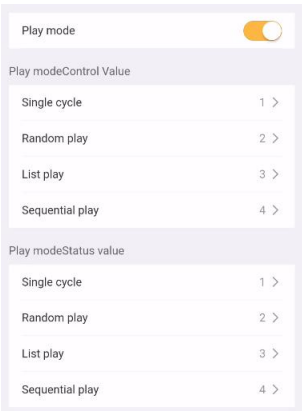
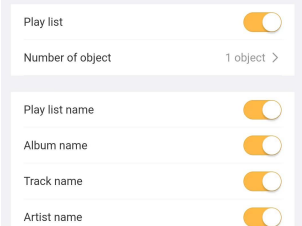
	Play mode	Used to set whether enable the function of play mode. When enabled, following 4 settings are valid.
	Single cycle	Used to set the output values and status feedback values for each play mode. The device will update the icon status of play mode according to the received feedback value. Options: 0~255
	Random play	
	List play	
	Sequential play	
	Play list	Used to set whether enable the function of play list. When enabled, next setting is valid.
	Number of object	Used to set the number of objects that control next/previous play list, 1 common object or 2 separate objects.  Options: One object, Two objects
	Play list name	Used to set the whether to display the play list name.
	Album name	Used to set the whether to display the album name.
	Track name	Used to set the whether to display the track name.
	Artist name	Used to set the whether to display the artist name.

### 5.12.17.2.KNX configuration

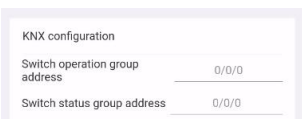
	Switch operation group address	1bit type. Input group address for sending on / off telegrams to the KNX bus to control device.  Telegrams: 1 - Power on, 0 - Power off
	Switch status group address	1bit type. Input group address for receiving on / off status from other devices on the KNX bus.  Telegrams: 1 - Power on, 0 - Power off

<p>Play pause operation group address 0/0/0</p> <p>Play pause status group address 0/0/0</p> <p>Previous song next song operation group address 0/0/0</p> <p>Volume adjustment operation group address 0/0/0</p> <p>Volume adjustment status group address 0/0/0</p> <p>Volume up/down operation group address 0/0/0</p> <p>Previous list next list operation group address 0/0/0</p> <p>Play mode operation group address 0/0/0</p> <p>Play mode status group address 0/0/0</p> <p>Mute operation group address 0/0/0</p> <p>Mute status group address 0/0/0</p>	<p>Pause operation group address</p>	<p>1bit type, visible when "Two objects" is selected. Input group address for sending the telegram to stop the music in the audio module. Telegram 1 is to stop, 0 is meaningless.</p>
<p>List name status group address 0/0/0</p> <p>Track name status group address 0/0/0</p> <p>Artist name status group address 0/0/0</p> <p>Album name status group address 0/0/0</p>	<p>Pause status group address</p>	<p>1bit type, visible when "Two objects" is selected. Input group address for receiving the status of pause in audio module. Telegram 1 is to stop, 0 is meaningless.</p>
	<p>Play operation group address</p>	<p>1bit type, visible when "Two objects" is selected. Input group address for sending the telegram to play the music in the audio module. Telegram 1 is to play, 0 is meaningless.</p>
	<p>Play status group address</p>	<p>1bit type, visible when "Two objects" is selected. Input group address for receiving the status of play in audio module. Telegram 1 is to play, 0 is meaningless.</p>
	<p>Play pause operation group address</p>	<p>1bit type, visible when "One object" is selected. Input group address for sending the telegram to play/pause the music in the audio module. Telegram 1 is to play, 0 is to pause.</p>
	<p>Play pause status group address</p>	<p>1bit type, visible when "One object" is selected. Input group address for receiving the status of play/pause in audio module, and feed back to APP display.</p>
	<p>Next song operation group address</p>	<p>1bit type, visible when "Two objects" is selected. Input group address for sending the telegram to switch the playing song in the audio module. Telegram 1 is to switch the next song, 0 is meaningless.</p>

	Previous song operation group address	1bit type, visible when "Two objects" is selected. Input group address for sending the telegram to switch the playing song in the audio module. Telegram 1 is to switch the previous song, 0 is meaningless.
	Previous song next song operation group address	1bit type, visible when "One object" is selected. Input group address for sending the telegram to switch the playing song in the audio module. Telegram 1 is to switch the next song, 0 is to switch the previous song.
	Volume adjustment operation group address	1byte type. Input group address for sending the telegram to adjust volume of the audio module. Telegrams value is according to different object types: 0..100 / 0..255
	Volume adjustment status group address	1byte type. Input group address for receiving the volume status of the audio module, and feed back to APP display. Telegrams value is according to different object types: 0..100 / 0..255
	Volume up/down operation group address	1bit type. Input group address for sending the telegram to adjust volume of the audio module.  Telegrams: 1-Increase volume, 0-Decrease volume
	Next list operation group address	1bit type, visible when "Two objects" is selected. Input group address for sending the telegram to switch playing list in the audio module. Telegram 1 is to switch the next list, 0 is meaningless.

Previous list operation group address	1bit type, visible when "Two objects" is selected. Input group address for sending the telegram to switch playing list in the audio module. Telegram 1 is to switch the previous list, 0 is meaningless.
Previous list next list operation group address	1bit type, visible when "One object" is selected. Input group address for sending the telegram to switch the playing list in the audio module. Telegram 1 is to switch the next list, 0 is to switch the previous list.
Play mode operation group address	1byte type. Input group address for sending the telegram of play mode to KNX bus to control device, the telegram for the different modes are preset by the parameter.
Play mode status group address	1byte type. Input group address for receiving status of play mode from other devices on the KNX bus, the receiving telegrams should be preset by parameters before the display status on the APP can be updated.
Mute operation group address	1bit type. Input group address for sending telegrams to control mute of audio module via the APP.  Telegrams: 1 - Mute, 0 - Cancel mute
Mute status group address	1bit type. Input group address for receiving the mute status of the audio module, and feed back to APP display.
List name status group address	14byte type. Input group address for receiving the list name, and feed back to APP display.
Track name status group address	14byte type. Input group address for receiving the song name, and feed back to APP display.

	Artist name status group address	14byte type. Input group address for receiving the artist name, and feed back to APP display.
	Album name status group address	14byte type. Input group address for receiving the album name , and feed back to APP display.

### 5.12.17.3. Controlling device

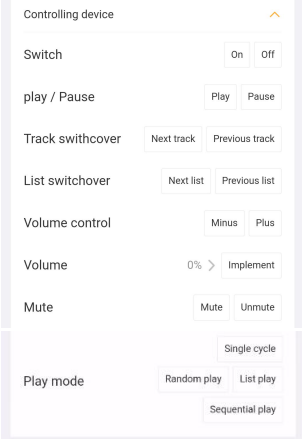
	Switch	There are two control buttons, "On" and "Off", which can be clicked to send the corresponding control commands to the KNX bus or the 485 bus
	Play/Pause	There are two control buttons, "Play" and "Pause", which can be clicked to send the corresponding control commands to the KNX bus or the 485 bus
	Track swithcover	There are two control buttons, "Next song" and "Previous song", which can be clicked to send the corresponding control commands to the KNX bus or the 485 bus
	List swithcover	There are two control buttons, "Next list" and "Previous list", which can be clicked to send the corresponding control commands to the KNX bus or the 485 bus
	Volume control	1bit is relative volume control, there are two control buttons, "Minus" and "Add", which can be clicked to send the corresponding control commands to the KNX bus or the 485 bus
	Volume	1byte is relative volume control, click on the volume value to pop-up a adjustment window, the adjustable range is 0~100%, after setting, click on "Implement" button to send the value to

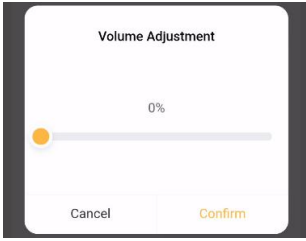
		<p>KNX bus or 485 bus.</p> 
	Mute	<p>There are two control buttons, "Mute" and "Unmute", which can be clicked to send the corresponding control commands to the KNX bus or the 485 bus.</p>
	Play mode	<p>There are four control buttons, "Single cycle", "Random play", "List play" and "Sequential play", which can be clicked to send the corresponding control commands to the KNX bus or the 485 bus.</p>

#### 5.12.17.4. Get device properties

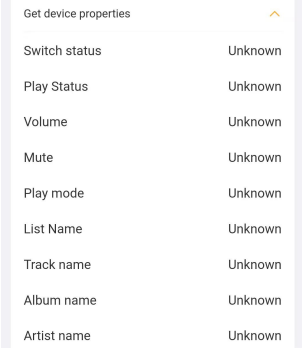
	Switch status	Display the received status, or "Unknown" if not sure.
	Play status	Display the received status, or "Unknown" if not sure.
	Volume	Display the received status, or "Unknown" if not sure.
	Mute	Display the received status, or "Unknown" if not sure.
	Play mode	Display the received status, or "Unknown" if not sure.
	List name	Display the received status, or "Unknown" if not sure.
	Track name	Display the received status, or "Unknown" if not sure.
	Album name	Display the received status, or "Unknown" if not sure.
	Artist name	Display the received status, or "Unknown" if not sure.

### 5.12.18 Energy monitoring

Type of Energy monitoring requires device model configuration; it supports access to KNX devices and 485 devices.

#### 5.12.18.1. Device model configuration

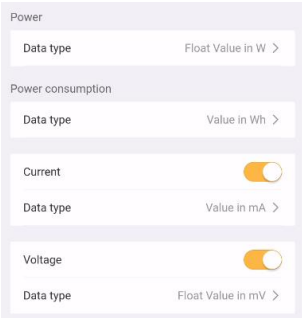
	Power data type	Used to set the datatype of power. Options: Float value in W(DPT 14.056), Float value in kW(DPT 9.024)
	Power consumption data type	Used to set the datatype of power consumption. Options: Value in Wh(DPT 13.010), Value in kWh(DPT 13.013)
	Current	Used to set whether to enable function of current data. When enabled, next settings is valid.
	Current data type	Used to set the datatype of current. Options: Value in mA(DPT 7.012), Float value in mA(DPT 9.021), Float value in A(DPT 14.019)
	Voltage	Used to set whether to enable function of voltage data. When enabled, next settings is valid.
	Voltage data type	Used to set the datatype of voltage. Options: Float value in mV(DPT 9.020), Float value in V(DPT 14.027)

#### 5.12.18.2. KNX configuration

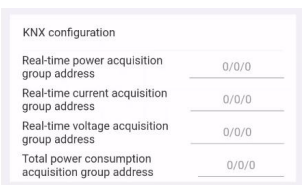
	Real-time power acquisition group address	2byte type. Input group address for receiving the power value from other devices on the KNX bus, and update to APP display.
---	---	---

	Real-time current acquisition group address	2byte type. Input group address for receiving the current value from other devices on the KNX bus, and update to APP display.
	Real-time voltage acquisition group address	2byte type. Input group address for receiving the voltage value from other devices on the KNX bus, and update to APP display.
	Total power consumption acquisition group address	2byte type. Input group address for receiving the power consumption value from other devices on the KNX bus, and update to APP display.

### 5.12.18.3. Controlling device

There are no device control commands that can be sent.

### 5.12.18.4. Get device properties

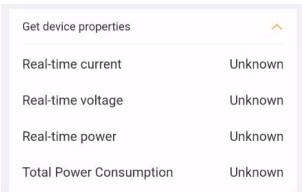
	Real-time current	Display the received status, or "Unknown" if not sure.
	Real-time voltage	Display the received status, or "Unknown" if not sure.
	Real-time power	Display the received status, or "Unknown" if not sure.
	Total power consumption	Display the received status, or "Unknown" if not sure.

### 5.12.19 AQI

Type of AQI requires device model configuration; it supports access to KNX devices and 485 devices.

#### 5.12.19.1. Device model configuration

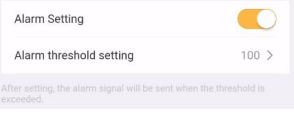
	Alarm setting	Used to set whether to enable alarm function. When enabled, next settings is valid.
	Alarm threshold setting	Used to set alarm threshold, optional range is 0~500. Once the threshold is exceeded will send an alarm telegram.

#### 5.12.19.2. KNX configuration

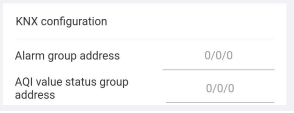
	Alarm group address	1bit type. Input group address for sending an alarm to KNX bus when AQI value exceeds the setting value.  Telegrams: 1 - Alarm, 0 - No alarm
	AQI value status group address	2byte type. Input group address for receiving the AQI value from other devices on the KNX bus, and update to APP display. Range is 0~500.

#### 5.12.19.3. Controlling device

There are no device control commands that can be sent.

#### 5.12.19.4. Get device properties

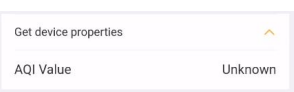
	AQI value	Display the received status, or "Unknown" if not sure.
---	-----------	--

### 5.12.20 PM2.5

Type of PM2.5 requires device model configuration; it supports access to KNX devices and 485 devices.

#### 5.12.20.1. Device model configuration

	PM2.5 data type	Set Value in ug/m3 as the data type of PM 2.5.
		Set Float Value in ug/m3 as the data type of PM 2.5.
	Unit	Units are displayed according to the selected data type.
	Alarm setting	Used to set whether to enable alarm function. When enabled, next settings is valid.
	Alarm threshold setting	Used to set alarm threshold, optional range is 0~999. Once the threshold is exceeded will send an alarm telegram.

#### 5.12.20.2. KNX configuration

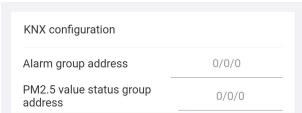
	Alarm group address	1bit type. Input group address for sending an alarm to KNX bus when PM2.5 value exceeds the setting value.  Telegrams: 1 - Alarm, 0 - No alarm
	PM2.5 value status group address	2byte type. Input group address for receiving the PM2.5 value from other devices on the KNX bus, and update to APP display.  Range is 0~999ug/m3.

#### 5.12.20.3. Controlling device

There are no device control commands that can be sent.

#### 5.12.20.4. Get device properties

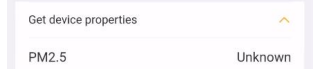
	PM2.5	Display the received status, or "Unknown" if not sure.
---	-------	--

#### 5.12.21 PM10

Type of PM10 requires device model configuration; it supports access to KNX devices and 485 devices.

##### 5.12.21.1. Device model configuration

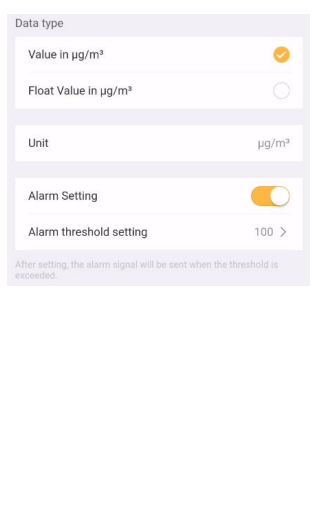
	PM10 data type	Set Value in ug/m3 as the data type of PM 10. Set Float Value in ug/m3 as the data type of PM 10.
	Unit	Units are displayed according to the selected data type.
	Alarm setting	Used to set whether to enable alarm function. When enabled, next settings is valid.
	Alarm threshold setting	Used to set alarm threshold, optional range is 0~999. Once the threshold is exceeded will send an alarm telegram.

##### 5.12.21.2. KNX configuration

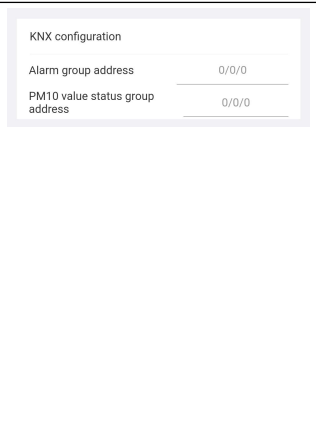
	Alarm group address	1bit type. Input group address for sending an alarm to KNX bus when PM10 value exceeds the setting value. Telegrams: 1 - Alarm, 0 - No alarm
	PM10 value status group address	2byte type. Input group address for receiving the PM10 value from other devices on the KNX bus, and update to APP display. Range is 0~999ug/m3.

### 5.12.21.3. Controlling device

There are no device control commands that can be sent.

### 5.12.21.4. Get device properties

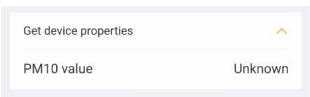
	PM10 value	Display the received status, or "Unknown" if not sure.
---	------------	--

## 5.12.22 Temperature sensor

Type of Temperature sensor requires device model configuration; it supports access to KNX devices and 485 devices.

### 5.12.22.1. Device model configuration

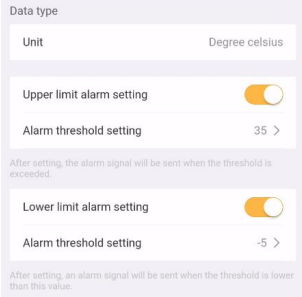
	Unit	The temperature unit is fixed at °C.
	Upper limit alarm setting	Used to set whether to enable upper limit alarm function. When enabled, next settings is valid.
	Alarm threshold setting	Used to set upper limit alarm threshold, optional range is -20~100. Once exceed threshold will send an alarm telegram.
	Lower limit alarm setting	Used to set whether to enable lower limit alarm function. When enabled, next settings is valid.
	Alarm threshold setting	Used to set lower limit alarm threshold, optional range is -20~100. Once lower than threshold will send an alarm telegram.

### 5.12.22.2.KNX configuration

	Room Temperature status group address	2byte type. Input group address for receiving the temperature value from other devices on the KNX bus, and update to APP display.  Range is -40~99°C.
	Low threshold alarm group address	1bit type. Input group address for sending an alarm to KNX bus when temperature value is lower than the setting value.  Telegrams: 1 - Alarm, 0 - No alarm
	High threshold alarm group address	1bit type. Input group address for sending an alarm to KNX bus when temperature value is higher than the setting value.  Telegrams: 1 - Alarm, 0 - No alarm

### 5.12.22.3.Controlling device

There are no device control commands that can be sent.

### 5.12.22.4.Get device properties

	Real-time temperature	Display the received status, or "Unknown" if not sure.
--	-----------------------	--

### 5.12.23 Humidity sensor

Type of Humidity sensor requires device model configuration; it supports access to KNX devices and 485 devices.

#### 5.12.23.1.Device model configuration

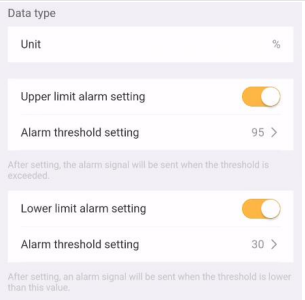
	Unit	The temperature unit is fixed at %.
	Upper limit alarm setting	Used to set whether to enable upper limit alarm function. When enabled, next settings is valid.
	Alarm threshold setting	Used to set upper limit alarm threshold, optional range is 0~100. Once exceed threshold will send an alarm telegram.
	Lower limit alarm setting	Used to set whether to enable lower limit alarm function. When enabled, next settings is valid.
	Alarm threshold setting	Used to set lower limit alarm threshold, optional range is 0~100. Once lower than threshold will send an alarm telegram.

#### 5.12.23.2.KNX configuration

	Humidity value status group address	2byte type. Input group address for receiving the humidity value from other devices on the KNX bus, and update to APP display. Range is 0~100%.
	Low threshold alarm group address	1bit type. Input group address for sending an alarm to KNX bus when humidity value is lower than the setting value. Telegrams: 1 - Alarm, 0 - No alarm
	High threshold alarm group address	1bit type. Input group address for sending an alarm to KNX bus when humidity value is higher than the setting value. Telegrams: 1 - Alarm, 0 - No alarm

### 5.12.23.3. Controlling device

There are no device control commands that can be sent.

### 5.12.23.4. Get device properties

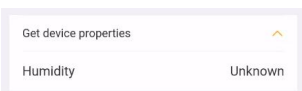
	Humidity	Display the received status, or "Unknown" if not sure.
---	----------	--

### 5.12.24 CO2 sensor

Type of CO2 sensor requires device model configuration; it supports access to KNX devices and 485 devices.

#### 5.12.24.1. Device model configuration

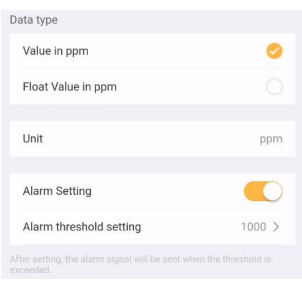
	CO2 data type	Set Value in ppm as the data type of CO2.
		Set Float Value in ppm as the data type of CO2.
	Unit	Units are displayed according to the selected data type.
	Alarm setting	Used to set whether to enable alarm function. When enabled, next settings is valid.
Alarm threshold setting	Used to set alarm threshold, optional range is 0~4000. Once the threshold is exceeded will send an alarm telegram.	

#### 5.12.24.2. KNX configuration

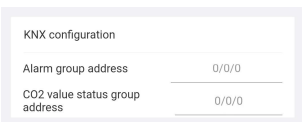
	Alarm group address	1bit type. Input group address for sending an alarm to KNX bus when CO2 value exceeds the setting value.  Telegrams: 1 - Alarm, 0 - No alarm
---	---------------------	--

	CO2 value status group address	2byte type. Input group address for receiving the CO2 value from other devices on the KNX bus, and update to APP display. Range is 0~999ug/m3.
--	--------------------------------	--

### 5.12.24.3. Controlling device

There are no device control commands that can be sent.

### 5.12.24.4. Get device properties

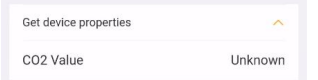
	CO2 value	Display the received status, or "Unknown" if not sure.
---	-----------	--

### 5.12.25 CO sensor

Type of CO sensor requires device model configuration; it supports access to KNX devices and 485 devices.

#### 5.12.25.1. Device model configuration

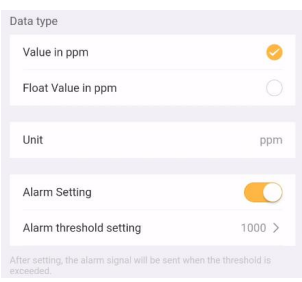
	CO data type	Set Value in ppm as the data type of CO.
		Set Float Value in ppm as the data type of CO.
	Unit	Units are displayed according to the selected data type.
	Alarm setting	Used to set whether to enable alarm function. When enabled, next settings is valid.
	Alarm threshold setting	Used to set alarm threshold, optional range is 0~9999. Once the threshold is exceeded will send an alarm telegram.

### 5.12.25.2.KNX configuration

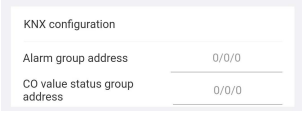
	Alarm group address	1bit type. Input group address for sending an alarm to KNX bus when CO value exceeds the setting value.  Telegrams: 1 - Alarm, 0 - No alarm
	CO value status group address	2byte type. Input group address for receiving the CO value from other devices on the KNX bus, and update to APP display. Range is 0~999ug/m3.

### 5.12.25.3.Controlling device

There are no device control commands that can be sent.

### 5.12.25.4.Get device properties

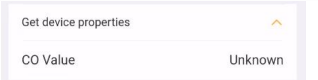
	CO value	Display the received status, or "Unknown" if not sure.
---	----------	--

### 5.12.26 Formaldehyde sensor

Type of Formaldehyde sensor requires device model configuration; it supports access to KNX devices, but not support to 485 interface and dry contact interface.

#### 5.12.26.1.Device model configuration

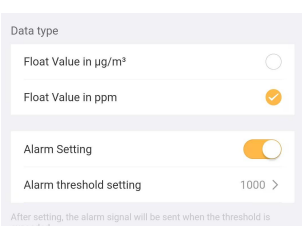
	Formaldehyde data type	Set Float Value in ppm as the data type of formaldehyde.  Set Float Value in ug/m3 as the data type of formaldehyde.
	Alarm setting	Used to set whether to enable alarm function. When enabled, next settings is valid.

	Alarm threshold setting	Used to set alarm threshold, optional range is 0~9999 /0~4000. Once the threshold is exceeded will send an alarm telegram.
--	-------------------------	---

### 5.12.26.2.KNX configuration

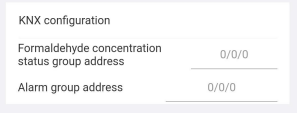
	Alarm group address	1bit type. Input group address for sending an alarm to KNX bus when formaldehyde value exceeds the setting value.  Telegrams: 1 - Alarm, 0 - No alarm
	Formaldehyde concentration status group address	2byte type. Input group address for receiving the formaldehyde value from other devices on the KNX bus, and update to APP display. Range is 0~9999ug/m3.

### 5.12.26.3.Controlling device

There are no device control commands that can be sent.

### 5.12.26.4.Get device properties

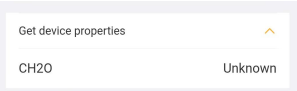
	CH2O	Display the received status, or "Unknown" if not sure.
---	------	--

### 5.12.27 VOC sensor

Type of VOC sensor requires device model configuration; it supports access to KNX devices and 485 devices.

#### 5.12.27.1.Device model configuration

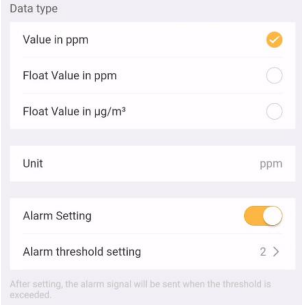
 <p>The screenshot shows a configuration panel for a VOC sensor. It includes sections for 'Data type' with radio buttons for 'Value in ppm' (selected), 'Float Value in ppm', and 'Float Value in µg/m³'. Below is a 'Unit' dropdown set to 'ppm'. An 'Alarm Setting' section has a toggle switch turned on and an 'Alarm threshold setting' field with a value of '2' and a right arrow. A small note at the bottom states: 'After setting, the alarm signal will be sent when the threshold is exceeded.'</p>	VOC data type	Set Value in ppm as the data type of VOC.
		Set Float Value in ppm as the data type of VOC.
		Set Float Value in ug/m3 as the data type of VOC.
	Unit	Units are displayed according to the selected data type.
	Alarm setting	Used to set whether to enable alarm function. When enabled, next settings is valid.
Alarm threshold setting	Used to set alarm threshold, optional range is 0~500/0~9990. Once the threshold is exceeded will send an alarm telegram.	

#### 5.12.27.2.KNX configuration

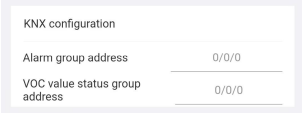
 <p>The screenshot shows a 'KNX configuration' panel with two input fields: 'Alarm group address' and 'VOC value status group address', both currently set to '0/0/0'.</p>	Alarm group address	1bit type. Input group address for sending an alarm to KNX bus when VOC value exceeds the setting value.  Telegrams: 1 - Alarm, 0 - No alarm
	VOC value status group address	2byte type. Input group address for receiving the VOC value from other devices on the KNX bus, and update to APP display. Range is 0~999ug/m3 or 0~4000ppm.

#### 5.12.27.3.Controlling device

There are no device control commands that can be sent.

#### 5.12.27.4. Get device properties

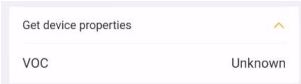
	VOC	Display the received status, or "Unknown" if not sure.
---	-----	--

#### 5.12.28 Brightness sensor

Type of Brightness sensor requires device model configuration; it supports access to KNX devices and 485 devices.

##### 5.12.28.1. Device model configuration

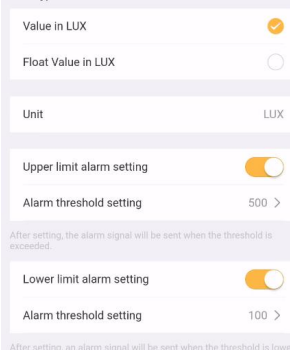
	Brightness data	Set Value in Lux as the data type of brightness.
	type	Set Float Value in Lux as the data type of brightness.
	Unit	Units are displayed according to the selected data type.
	Upper limit alarm setting	Used to set whether to enable upper limit alarm function. When enabled, next settings is valid.
	Alarm threshold setting	Used to set upper limit alarm threshold, optional range is 0~9999. Once exceed threshold will send an alarm telegram.
	Lower limit alarm setting	Used to set whether to enable lower limit alarm function. When enabled, next settings is valid.
	Alarm threshold setting	Used to set lower limit alarm threshold, optional range is 0~9999. Once lower than threshold will send an alarm telegram.

##### 5.12.28.2. KNX configuration

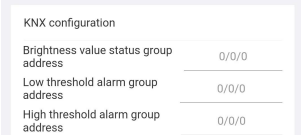
	Brightness value status group address	2byte type. Input group address for receiving the brightness value from other devices on the KNX bus, and update to APP display. Range is 0~50000lux.
---	---------------------------------------	---

	Low threshold alarm group address	1bit type. Input group address for sending an alarm to KNX bus when brightness value is lower than the setting value.  Telegrams: 1 - Alarm, 0 - No alarm
	High threshold alarm group address	1bit type. Input group address for sending an alarm to KNX bus when brightness value is higher than the setting value.  Telegrams: 1 - Alarm, 0 - No alarm

### 5.12.28.3. Controlling device

There are no device control commands that can be sent.

### 5.12.28.4. Get device properties

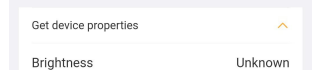
	Brightness	Display the received status, or "Unknown" if not sure.
---	------------	--

### 5.12.29 Wind sensor

Type of Wind sensor requires device model configuration; it supports access to KNX devices and 485 devices.

#### 5.12.29.1.Device model configuration

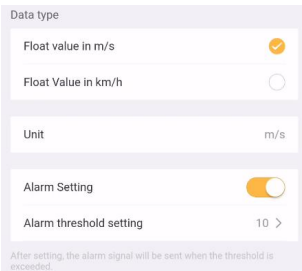
	Wind speed data	Set Float Value in m/s as the data type of wind speed.
	type	Set Float Value in km/h as the data type of wind speed.
	Unit	Units are displayed according to the selected data type.
	Alarm setting	Used to set whether to enable alarm function. When enabled, next settings is valid.
	Alarm threshold setting	Used to set alarm threshold, optional range is 0~50/0~183. Once the threshold is exceeded will send an alarm telegram.

#### 5.12.29.2.KNX configuration

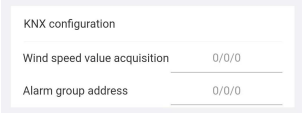
	Wind speed value acquisition	2byte type. Input group address for receiving the wind speed value from other devices on the KNX bus, and update to APP display.
	Alarm group address	1bit type. Input group address for sending an alarm to KNX bus when wind speed value exceeds the setting value.  Telegrams: 1 - Alarm, 0 - No alarm

#### 5.12.29.3.Controlling device

There are no device control commands that can be sent.

#### 5.12.29.4.Get device properties

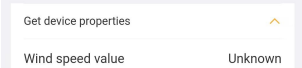
	Wind speed	Display the received status, or "Unknown" if not sure.
---	------------	--

### 5.12.30 General IO Device

Type of General IO Device requires device model configuration; it supports access to KNX devices and dry contact interface.

#### 5.12.30.1.Device model configuration

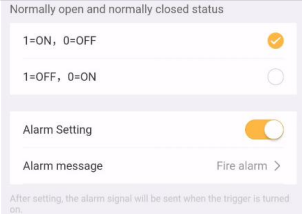
	Normally open and normally closed status	Set 1=ON, 0=OFF as the telegrams of normally open and normally closed.
		Set 0=ON, 1=OFF as the telegrams of normally open and normally closed.
	Alarm setting	Used to set whether to enable alarm function. When enabled, next settings is valid.
	Alarm message	Used to set alarm message, only allow to input Chinese and English and space, limited to 14byte.  When the dry contact interface is not configured, the alarm signal will be sent when the device is triggered to turn on.  When was configured, if the device is off, the alarm signal will be sent when the open status is triggered; if it is on, the alarm signal will be sent when the dry contact is shorted.

#### 5.12.30.2.KNX configuration

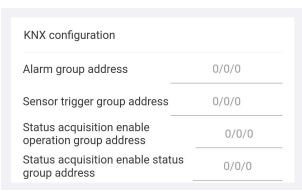
	Alarm group address	1bit type. Input group address for sending an alarm to KNX bus when the open status is triggered by IO device.  Telegrams: 1 - Alarm, 0 - No alarm
---	---------------------	--

	Sensor trigger group address	1bit type. Input group address for receiving the IO value from other devices on the KNX bus, and update to APP display. Telegrams are defined by the parameter.
	Status acquisition enable operation group address	1bit type. Input group address for sending telegrams of status acquisition to the KNX bus. Telegrams: 1-Enable, 0-Disable.  When enabled, the gateway can be allowed to receive the status of IO device, or it will not be processed. <i>Note: the function is generally associated with the automation scene, which you can set in the "GVS Smart" APP.</i>
	Status acquisition enable status group address	1bit type. Input group address for receiving the enable status of acquisition function. Telegrams: 1-Enable, 0-Disable.

### 5.12.30.3. Controlling device

There are no device control commands that can be sent.

### 5.12.30.4. Get device properties

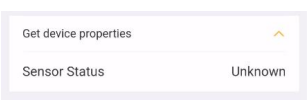
	Sensor status	Display the received status, or "Unknown" if not sure.
---	---------------	--

#### **5.12.31 Fire alarm**

Type of Fire alarm requires device model configuration; it supports access to KNX devices and dry contact interface. The configuration is the the same as that of the General IO sensor.

#### **5.12.32 Flood alarm**

Type of Flood alarm requires device model configuration; it supports access to KNX devices and dry contact interface. The configuration is the the same as that of the General IO sensor.

#### **5.12.33 Gas alarm**

Type of Gas alarm requires device model configuration; it supports access to KNX devices and dry contact interface. The configuration is the the same as that of the General IO sensor.

#### **5.12.34 Smoke alarm**

Type of Smoke alarm requires device model configuration; it supports access to KNX devices and dry contact interface. The configuration is the the same as that of the General IO sensor.

### 5.12.35 Motion sensor

Type of Motion sensing sensor does not require device model configuration; it supports access to 485 devices, also supports communication via KNX bus.

#### 5.12.35.1.KNX configuration

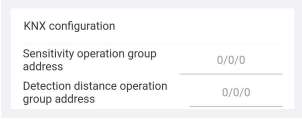
	<p>Sensitivity operation group address</p>	<p>1byte type. Input group address for adjusting the sensitivity of motion sensor. Range is 0~100.</p>
	<p>Detection distance operation group address</p>	<p>1byte type. Input group address for adjusting the detection distance of motion sensor. Range is 0~100.</p>

#### 5.12.35.2.Controlling device

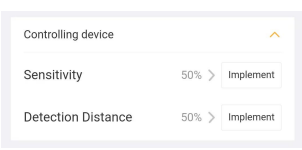
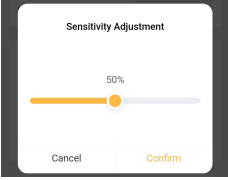
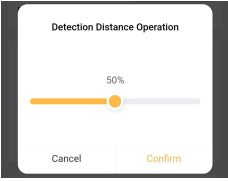
	<p>Sensitivity</p>	<p>Click on the sensitivity value to pop-up a adjustment window, the adjustable range is 0~100%, after setting, click on "Implement" button to send the value to KNX bus or 485 bus.</p> 
	<p>Detection distance</p>	<p>Click on the detection distance value to pop-up a adjustment window, the adjustable range is 0~100%, after setting, click on "Implement" button to send the value to KNX bus or 485 bus.</p> 

### 5.12.35.3. Get device properties

There are no device statuses that can be obtained.

### 5.12.36 Fresh Air ventilator

Type of Fresh Air ventilator requires device model configuration; it supports access to 485 devices, also supports communication via KNX bus.

#### 5.12.36.1. Device model configuration

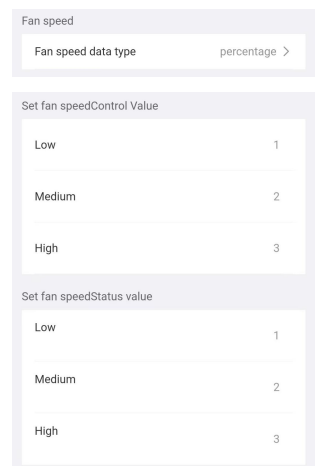
	<p>Fan speed data type</p>	<p>Used to set the datatype of 1byte fan speed. Options: Fan stage (DPT 5.100), Percentage (DPT 5.001).</p>
	<p>Fan speed low</p>	<p>Used to set the output values and status feedback values for each fan speed switchover, support 3 fan speeds: low, medium, high.</p>
	<p>Fan speed medium</p>	
	<p>Fan speed high</p>	<p>Options according to wind object datatype: 0..255/0..100</p>

#### 5.12.36.2. KNX configuration

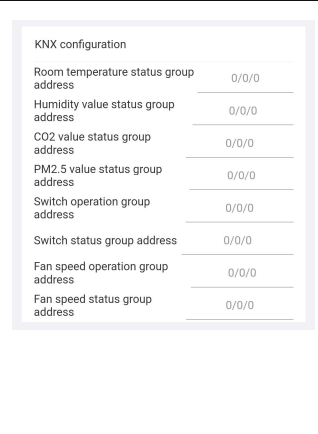
	<p>Switch operation group address</p>	<p>1bit type. Input group address for sending on / off telegrams to the KNX bus to control device.  Telegrams: 1 - Power on, 0 - Power off</p>
	<p>Switch status group address</p>	<p>1bit type. Input group address for receiving on / off status from other devices on the KNX bus.  Telegrams: 1 - Power on, 0 - Power off</p>

	Fan speed operation group address	1byte type. Input group address, activate the corresponding fan speed on APP for sending fan speed value to the KNX bus to control device. The corresponding telegram value of each fan speed is defined by the parameter.
	Fan speed status group address	1byte type. Input group address for receiving specified value from other devices on the KNX bus, the display status of fan speed on APP is updated to the corresponding fan speed.
	PM2.5 value status group address	2byte type. Input group address for receiving the PM2.5 value detected by the sensor from other devices on the KNX bus, and can be updated to the display. The telegram value is defined by the object datatype.
	CO2 value status group address	2byte type. Input group address for receiving the CO2 value detected by the sensor from other devices on the KNX bus, and can be updated to the display. The telegram value is defined by the object datatype.
	Room temperature status group address	2byte type. Input group address for receiving the temperature value detected by the temperature sensor from other devices on the KNX bus.
	Humidity value status group address	2byte type. Input group address for receiving the humidity value detected by the humidity sensor from other devices on the KNX bus.

### 5.12.36.3. Controlling device

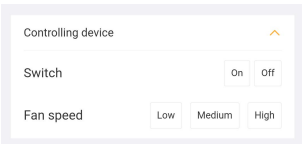
	Switch	There are two control buttons, "On" and "Off", which can be clicked to send the corresponding control commands to the KNX bus or the 485 bus
	Fan speed	There are three control buttons, "Low", "Medium", and "High", which can be clicked to send the corresponding control commands to the KNX bus or the 485 bus.

### 5.12.36.4. Get device properties

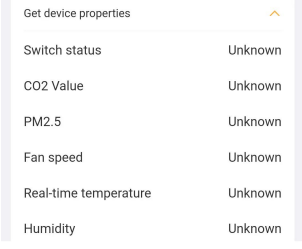
	Switch status	Display the received status, or "Unknown" if not sure.
	PM2.5	Display the received status, or "Unknown" if not sure.
	CO2	Display the received status, or "Unknown" if not sure.
	Fan speed	Display the received status, or "Unknown" if not sure.
	Real-time temperature	Display the received status, or "Unknown" if not sure.
	Humidity	Display the received status, or "Unknown" if not sure.

### 5.12.37 Panasonic Fresh Air

Type of Panasonic Fresh Air requires device model configuration; it supports access to 485 devices, also supports communication via KNX bus.

#### 5.12.37.1. Device model configuration

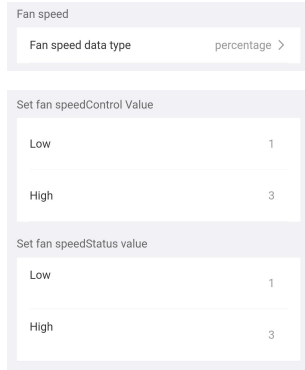
 <p>Fan speed data type: percentage &gt;</p> <p>Set fan speedControl Value</p> <p>Low: 1</p> <p>High: 3</p> <p>Set fan speedStatus value</p> <p>Low: 1</p> <p>High: 3</p>	Fan speed data type	Used to set the datatype of 1byte fan speed. Options: Fan stage (DPT 5.100), Percentage (DPT 5.001).
	Fan speed low	Used to set the output values and status feedback values for each fan speed switchover, support 2 fan speeds: low, high. Options according to wind object datatype: 0..255/0..100
	Fan speed high	

#### 5.12.37.2. KNX configuration

 <p>KNX configuration</p> <p>Switch operation group address: 0/0/0</p> <p>Switch status group address: 0/0/0</p> <p>Fan speed operation group address: 0/0/0</p> <p>Fan speed status group address: 0/0/0</p>	Switch operation group address	1bit type. Input group address for sending on / off telegrams to the KNX bus to control device.  Telegrams: 1 - Power on, 0 - Power off
	Switch status group address	1bit type. Input group address for receiving on / off status from other devices on the KNX bus.  Telegrams: 1 - Power on, 0 - Power off
	Fan speed operation group address	1byte type. Input group address, activate the corresponding fan speed on APP for sending fan speed value to the KNX bus to control device. The corresponding telegram value of each fan speed is defined by the parameter.

	<p>Fan speed status group address</p>	<p>1byte type. Input group address for receiving specified value from other devices on the KNX bus, the display status of fan speed on APP is updated to the corresponding fan speed.</p>
--	---------------------------------------	---

**5.12.37.3. Controlling device**

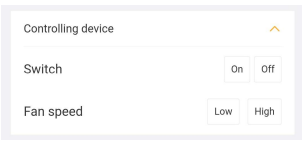
	<p>Switch</p>	<p>There are two control buttons, "On" and "Off", which can be clicked to send the corresponding control commands to the KNX bus or the 485 bus</p>
	<p>Fan speed</p>	<p>There are two control buttons, "Low" and "High", which can be clicked to send the corresponding control commands to the KNX bus or the 485 bus.</p>

**5.12.37.4. Get device properties**

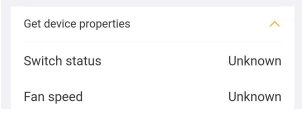
	<p>Switch status</p>	<p>Display the received status, or "Unknown" if not sure.</p>
	<p>Fan speed</p>	<p>Display the received status, or "Unknown" if not sure.</p>

### 5.12.38 Humidifier

Type of Humidifier requires device model configuration; it supports access to 485 devices, also supports communication via KNX bus.

#### 5.12.38.1.Device model configuration

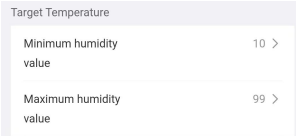
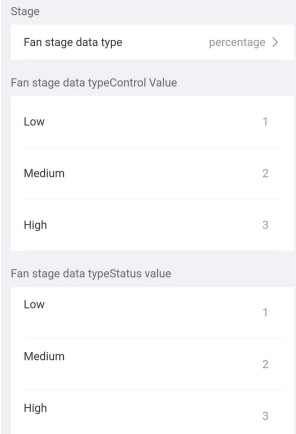
	<p>Minimum humidity value</p>	<p>Used to set the upper and lower thresholds of humidity. The minimum value must be less than the maximum value. Optional</p>
	<p>Maximum humidity value</p>	<p>range is 1~99%.</p>
	<p>Fan speed data type</p>	<p>Used to set the datatype of 1byte fan speed. Options: Fan stage (DPT 5.100), Percentage (DPT 5.001).</p>
	<p>Low</p>	<p>Used to set the output values and status feedback values for each fan speed switchover, support 3 fan speeds low, medium, high.</p>
	<p>Medium</p>	
	<p>High</p>	
	<p>Options according to wind object datatype: 0..255/0..100</p>	

#### 5.12.38.2.KNX configuration

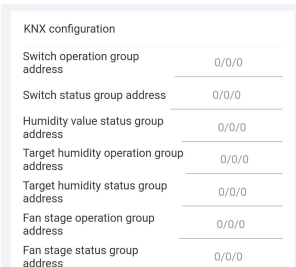
	<p>Switch operation group address</p>	<p>1bit type. Input group address for sending on / off telegrams to the KNX bus to control device.</p> <p>Telegrams: 1 - Power on, 0 - Power off</p>
	<p>Switch status group address</p>	<p>1bit type. Input group address for receiving on / off status from other devices on the KNX bus.</p> <p>Telegrams: 1 - Power on, 0 - Power off</p>

	Fan stage operation group address	1byte type. Input group address, activate the corresponding fan speed on APP for sending fan speed value to the KNX bus to control device. The corresponding telegram value of each fan speed is defined by the parameter.
	Fan stage status group address	1byte type. Input group address for receiving specified value from other devices on the KNX bus, the display status of fan speed on APP is updated to the corresponding fan speed.
	Humidity value status group address	1byte type. Input group address for receiving the humidity value detected by the humidity sensor from other devices on the KNX bus.
	Target humidity operation group address	1byte type. Input group address for sending target humidity to the KNX bus.
	Target humidity status group address	1byte type. Input group address for receiving the status of target humidity from other devices on the KNX bus.

### 5.12.38.3. Controlling device

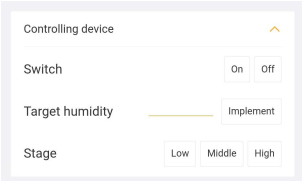
 <p>The screenshot shows a control panel titled 'Controlling device'. It includes a 'Switch' section with 'On' and 'Off' buttons, a 'Target humidity' section with a slider and an 'Implement' button, and a 'Stage' section with 'Low', 'Middle', and 'High' buttons.</p>	Switch	There are two control buttons, "On" and "Off", which can be clicked to send the corresponding control commands to the KNX bus or the 485 bus
---	--------	--

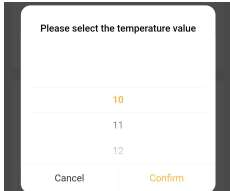
	Target humidity	<p>Click on the target humidity value to pop-up a adjustment window, after setting, click on "Implement" button to send the value to KNX bus or 485 bus.</p> 
	Stage	<p>There are two control buttons, "Low", "Medium" and "High", which can be clicked to send the corresponding control commands to the KNX bus or the 485 bus.</p>

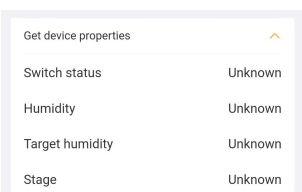

**5.12.38.4. Get device properties**

	Switch status	Display the received status, or "Unknown" if not sure.
	Humidity	Display the received status, or "Unknown" if not sure.
	Target humidity	Display the received status, or "Unknown" if not sure.
	Stage	Display the received status, or "Unknown" if not sure.

### 5.12.39 Switch panel

Type of Switch panel requires device model configuration; it supports access to KNX devices, but not support to 485 interface and dry contact interface.

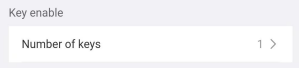
#### 5.12.39.1.Device model configuration

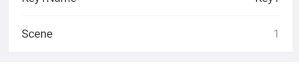
	Number of keys	Used to set the number of keys, up to 8 keys.
<p>Switch:</p> 	Key function	Used to set the key function, options: Switch, Scene
<p>Scene:</p> 	Key name	Used to set the name of key, up to input 18 characters (Including Chinese alphanumeric or other special characters).
	Scene	This parameter is visible when “Scene” is selected. Used to set the scene number, options:1~64.

#### 5.12.39.2.KNX configuration

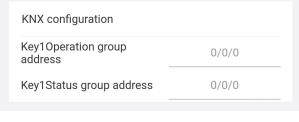
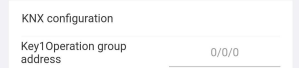
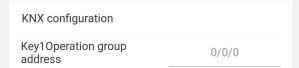
	Key operation group address	This parameter is visible when “Switch” is selected. 1bit type. Input group address for sending on / off telegrams to the KNX bus to control device. Telegrams: 1 - Power on, 0 - Power off
	Key status group address	This parameter is visible when “Switch” is selected. 1bit type. Input group address for receiving on / off status from other devices on the KNX bus. Telegrams: 1 - Power on, 0 - Power off
	Key operation group address	This parameter is visible when “Scene” is selected. 1byte type. Input group address for recalling scene via the KNX bus. Telegrams: 0~63

### 5.12.39.3. Controlling device

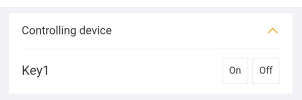
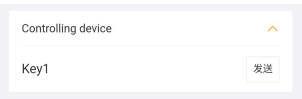
	key	This parameter is visible when "Switch" is selected. There are two control buttons, "On" and "Off", which can be clicked to send the corresponding control commands to the KNX bus or the 485 bus
	key	This parameter is visible when "Scene" is selected. Click button to recall scene.

### 5.12.39.4. Get device properties

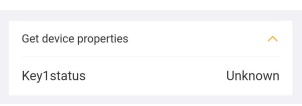
	Key status	Display the received status, or "Unknown" if not sure.
---	------------	--

### 5.12.40 Smart screen

Type of Smart screen requires device model configuration; it supports access to 485 devices, also supports communication via KNX bus.

#### 5.12.40.1. Device model configuration

 <p>SceneDevice 1 &gt;          SensorDevice 0 &gt;          LightDevice 0 &gt;          ACDevice 0 &gt;          Floor heatingDevice 0 &gt;          VentilationDevice 0 &gt;          SocketDevice 0 &gt;          CurtainDevice 0 &gt;          HeaterDevice 0 &gt;          Background musicDevice 0 &gt;</p>	Scene device	Used to associate the default scenes of the APP. Up to set 8 devices.  <i>Note: the same device cannot be selected repeatedly, as below.</i>
	Sensor device	Used to associate the sensors of the APP with Temperature, Humidity, PM2.5, Formaldehyde, TVOC, CO2, and 2 customized switch devices.
	Light device	Used to associate the light devices of the APP. Up to set 35 devices.
	AC device	Used to associate the AC devices of the APP. Up to set 12 devices.
	Floor heating device	Used to associate the floor heating devices of the APP. Up to set 12 devices.
	Ventilation device	Used to associate the ventilation devices of the APP. Up to set 12 devices.
	Socket device	Used to associate the socket devices of the APP. Up to set 16 devices.
	Curtain device	Used to associate the curtain devices of the APP. Up to set 16 devices.
	Heater device	Used to associate the heater devices of the APP. Up to set 16 devices.

	Background music device	Used to associate the background music devices of the APP. Up to set 16 devices.
--	-------------------------	--

#### **5.12.40.2.KNX configuration**

There are no KNX objects that can be configured.

#### **5.12.40.3.Controlling device**

There are no device control commands that can be sent.

#### **5.12.40.4.Get device properties**

There are no device status that can be received.

### 5.12.41 Integrated environmental sensor

Type of Integrated environmental sensor requires device model configuration; it supports access to 485 devices, also supports communication via KNX bus.

#### 5.12.41.1. Device model configuration

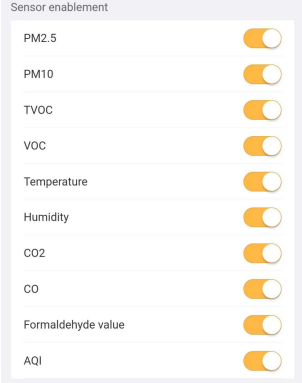
 <p>Sensor enablement</p> <ul style="list-style-type: none"> <li>PM2.5 <input checked="" type="checkbox"/></li> <li>PM10 <input checked="" type="checkbox"/></li> <li>TVOC <input checked="" type="checkbox"/></li> <li>VOC <input checked="" type="checkbox"/></li> <li>Temperature <input checked="" type="checkbox"/></li> <li>Humidity <input checked="" type="checkbox"/></li> <li>CO2 <input checked="" type="checkbox"/></li> <li>CO <input checked="" type="checkbox"/></li> <li>Formaldehyde value <input checked="" type="checkbox"/></li> <li>AQI <input checked="" type="checkbox"/></li> </ul>	PM2.5	<p>Used to enable each operation mode.</p> <p>Used to enable each type of sensors. If enabled, you can set the data type of the sensor. More details please see Chapter 5.12.19 to Section 5.12.27.</p> <p><i>Note: at least one sensor is enabled.</i></p>
	PM10	
	TVOC	
	VOC	
	Temperature	
	Humidity	
	CO2	
	CO	
	Formaldehyde value	
	AQI	

#### 5.12.41.2. KNX configuration

More details please see Chapter 5.12.19 to Section 5.12.27.

#### 5.12.41.3. Controlling device

More details please see Chapter 5.12.19 to Section 5.12.27.

#### 5.12.41.4. Get device properties

More details please see Chapter 5.12.19 to Section 5.12.27.

### 5.12.42 KNX AQI

Type of KNX AQI requires device model configuration; it supports access to KNX devices and 485 devices.

#### 5.12.42.1. Device model configuration

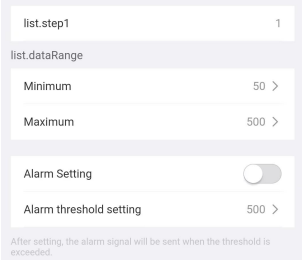
	Adjustment step	Used to set the adjustment step value, it is default by 1.
	Data range	Used to set the data range of AQI. The minimum value must be less than the maximum value. Optional range is 0~500.
	Alarm setting	Used to set whether to enable alarm function. When enabled, next settings is valid.
	Alarm threshold setting	Used to set alarm threshold, optional range is 0~500, but need to be in the setting value range of minimum and maximum.  Once the threshold is exceeded will send an alarm telegram.

#### 5.12.42.2. KNX configuration

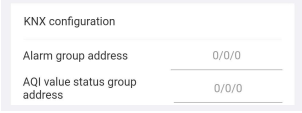
	Alarm group address	1bit type. Input group address for sending an alarm to KNX bus when AQI value exceeds the setting value.  Telegrams: 1 - Alarm, 0 - No alarm
	AQI value status group address	2byte type. Input group address for receiving the AQI value from other devices on the KNX bus, and update to APP display.

#### 5.12.42.3. Controlling device

There are no device control commands that can be sent.

#### 5.12.42.4. Get device properties

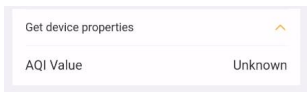
	AQI value	Display the received status, or "Unknown" if not sure.
---	-----------	--

#### 5.12.43 KNX PM2.5

Type of KNX PM2.5 requires device model configuration; it supports access to KNX devices and 485 devices.

##### 5.12.43.1. Device model configuration

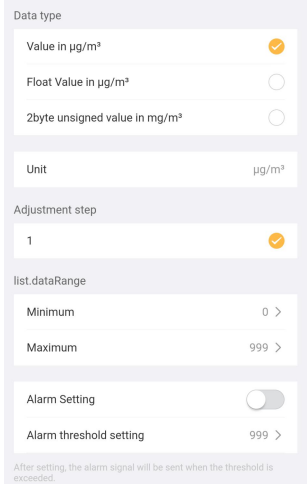
	PM2.5 data type	Set Value in ug/m3 as the data type of PM 2.5.
		Set Float Value in ug/m3 as the data type of PM 2.5.
		Set 2byte unsigned value in mg/m3 as the data type of PM 2.5.
	Unit	Units are displayed according to the selected data type.
	Adjustment step	Used to set the adjustment step value, it is default by 1 when unit is ug/m3. it can be set to 0.001 or 0.01 when unit is mg/m3.
	Data range	Used to set the data range of PM2.5. The minimum value must be less than the maximum value. Optional range is 0~999ug/m3 / 0~1mg/m3.
Alarm setting	Used to set whether to enable alarm function. When enabled, next settings is valid.	
Alarm threshold setting	Used to set alarm threshold, optional range is 0~999ug/m3 / 0~1mg/m3, but need to be in the setting value range of minimum and maximum.  Once the threshold is exceeded will send an alarm telegram.	

### 5.12.43.2.KNX configuration

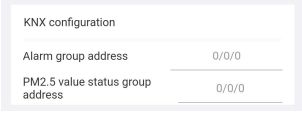
	Alarm group address	1bit type. Input group address for sending an alarm to KNX bus when PM2.5 value exceeds the setting value.  Telegrams: 1 - Alarm, 0 - No alarm
	PM2.5 value status group address	2byte type. Input group address for receiving the PM2.5 value from other devices on the KNX bus, and update to APP display.

### 5.12.43.3.Controlling device

There are no device control commands that can be sent.

### 5.12.43.4.Get device properties

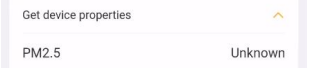
	PM2.5	Display the received status, or "Unknown" if not sure.
---	-------	--

## 5.12.44 KNX PM10

Type of KNX PM10 requires device model configuration; it supports access to KNX devices and 485 devices.

### 5.12.44.1.Device model configuration

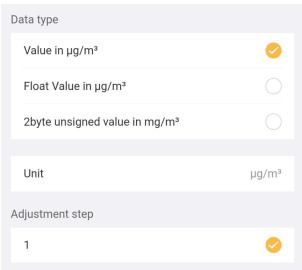
	PM10 data type	Set Value in ug/m3 as the data type of PM 10.
		Set Float Value in ug/m3 as the data type of PM 10.
		Set 2byte unsigned value in mg/m3 as the data type of PM 10.
Unit	Units are displayed according to the selected data type.	
Adjustment step	Used to set the adjustment step value, it is default by 1 when unit is ug/m3. it can be set to 0.01 or 0.1 when unit is mg/m3.	

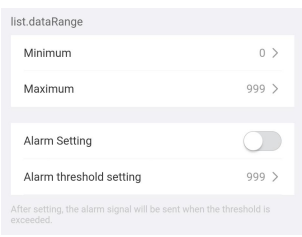
 <p>list.dataRange</p> <p>Minimum 0 &gt;</p> <p>Maximum 999 &gt;</p> <p>Alarm Setting <input type="checkbox"/></p> <p>Alarm threshold setting 999 &gt;</p> <p><small>After setting, the alarm signal will be sent when the threshold is exceeded.</small></p>	Data range	Used to set the data range of PM10. The minimum value must be less than the maximum value. Optional range is 0~999ug/m3 / 0~1mg/m3.
	Alarm setting	Used to set whether to enable alarm function. When enabled, next settings is valid.
	Alarm threshold setting	Used to set alarm threshold, optional range is 0~999ug/m3 / 0~1mg/m3, but need to be in the setting value range of minimum and maximum.  Once the threshold is exceeded will send an alarm telegram.

#### 5.12.44.2.KNX configuration

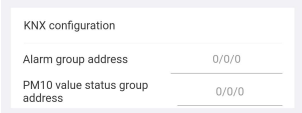
 <p>KNX configuration</p> <p>Alarm group address 0/0/0</p> <p>PM10 value status group address 0/0/0</p>	Alarm group address	1bit type. Input group address for sending an alarm to KNX bus when PM10 value exceeds the setting value.  Telegrams: 1 - Alarm, 0 - No alarm
	PM10 value status group address	2byte type. Input group address for receiving the PM10 value from other devices on the KNX bus, and update to APP display.

#### 5.12.44.3.Controlling device

There are no device control commands that can be sent.

#### 5.12.44.4.Get device properties

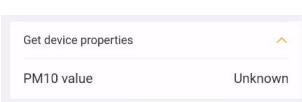
 <p>Get device properties</p> <p>PM10 value Unknown</p>	PM10 value	Display the received status, or "Unknown" if not sure.
--	------------	--

### 5.12.45 KNX Temperature sensor

Type of KNX Temperature sensor requires device model configuration; it supports access to KNX devices and 485 devices.

#### 5.12.45.1.Device model configuration

	Unit	The temperature unit can be set to °C or °F.
	Adjustment step	Used to set the adjustment step value, it can be set to 1, 0.5 or 0.1 when unit is °C. it can be set to 1 or 0.1 when unit is °F.
	Data range	Used to set the data range of temperature. The minimum value must be less than the maximum value. Optional range is -40~99°C / -40~210°F.
	Upper limit alarm setting	Used to set whether to enable upper limit alarm function. When enabled, next settings is valid.
	Alarm threshold setting	Used to set upper limit alarm threshold, optional range is -40~99°C / -40~210°F, but need to be in the setting value range of minimum and maximum, and the lower limit can not be higher than the upper limit. Once exceed threshold will send an alarm telegram.
	Lower limit alarm setting	Used to set whether to enable lower limit alarm function. When enabled, next settings is valid.
	Alarm threshold setting	Used to set lower limit alarm threshold, optional range is -40~99°C / -40~210°F, but need to be in the setting value range of minimum and maximum, and the lower limit can not be higher than the upper limit. Once lower than threshold will send an alarm telegram.

**5.12.45.2.KNX configuration**

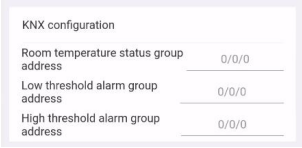
	Room Temperature status group address	2byte type. Input group address for receiving the temperature value from other devices on the KNX bus, and update to APP display.
	Low threshold alarm group address	1bit type. Input group address for sending an alarm to KNX bus when temperature value is lower than the setting value.  Telegrams: 1 - Alarm, 0 - No alarm
	High threshold alarm group address	1bit type. Input group address for sending an alarm to KNX bus when temperature value is higher than the setting value.  Telegrams: 1 - Alarm, 0 - No alarm

**5.12.45.3.Controlling device**

There are no device control commands that can be sent.

**5.12.45.4.Get device properties**

	Real-time temperature	Display the received status, or "Unknown" if not sure.
---	--------------------------	--

### 5.12.46 KNX Humidity sensor

Type of KNX Humidity sensor requires device model configuration; it supports access to KNX devices and 485 devices.

#### 5.12.46.1.Device model configuration

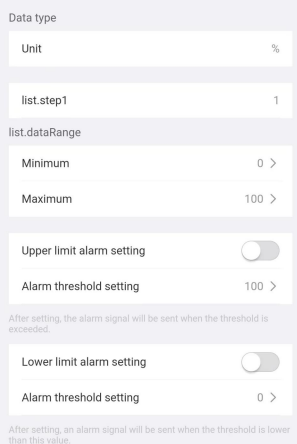
	Unit	The temperature unit is fixed at %.
	Adjustment step	Used to set the adjustment step value, it is default by 1.
	Data range	Used to set the data range of humidity. The minimum value must be less than the maximum value. Optional range is 0~100%.
	Upper limit alarm setting	Used to set whether to enable upper limit alarm function. When enabled, next settings is valid.
	Alarm threshold setting	Used to set upper limit alarm threshold, optional range is 0~100 but need to be in the setting value range of minimum and maximum, and the lower limit can not be higher than the upper limit.  Once exceed threshold will send an alarm telegram.
	Lower limit alarm setting	Used to set whether to enable lower limit alarm function. When enabled, next settings is valid.
	Alarm threshold setting	Used to set lower limit alarm threshold, optional range is 0~100 but need to be in the setting value range of minimum and maximum, and the lower limit can not be higher than the upper limit.  Once lower than threshold will send an alarm telegram.

### 5.12.46.2.KNX configuration

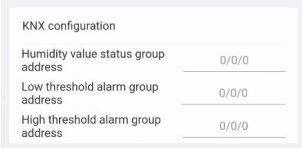
	<p>Humidity value status group address</p>	<p>2byte type. Input group address for receiving the humidity value from other devices on the KNX bus, and update to APP display.</p>
	<p>Low threshold alarm group address</p>	<p>1bit type. Input group address for sending an alarm to KNX bus when humidity value is lower than the setting value.</p> <p>Telegrams: 1 - Alarm, 0 - No alarm</p>
	<p>High threshold alarm group address</p>	<p>1bit type. Input group address for sending an alarm to KNX bus when humidity value is higher than the setting value.</p> <p>Telegrams: 1 - Alarm, 0 - No alarm</p>

### 5.12.46.3.Controlling device

There are no device control commands that can be sent.

### 5.12.46.4.Get device properties

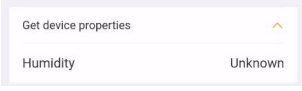
	<p>Humidity</p>	<p>Display the received status, or "Unknown" if not sure.</p>
---	-----------------	---

### 5.12.47 KNX CO2 sensor

Type of KNX CO2 sensor requires device model configuration; it supports access to KNX devices and 485 devices.

#### 5.12.47.1. Device model configuration

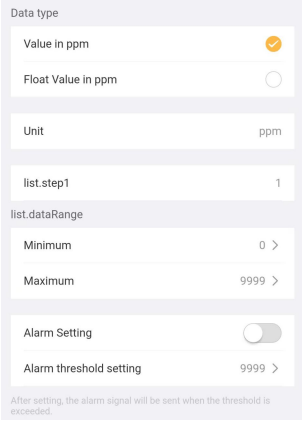
	CO2 data type	Set Value in ppm as the data type of CO2.
		Set Float Value in ppm as the data type of CO2.
	Unit	Units are displayed according to the selected data type.
	Adjustment step	Used to set the adjustment step value, it is default by 1.
	Data range	Used to set the data range of CO2. The minimum value must be less than the maximum value. Optional range is 0~9999ppm.
	Alarm setting	Used to set whether to enable alarm function. When enabled, next settings is valid.
Alarm threshold setting	Used to set alarm threshold, optional range is 0~9999ppm but need to be in the setting value range of minimum and maximum. Once the threshold is exceeded will send an alarm telegram.	

#### 5.12.47.2. KNX configuration

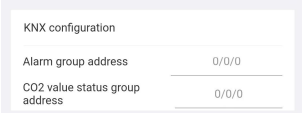
	Alarm group address	1bit type. Input group address for sending an alarm to KNX bus when CO2 value exceeds the setting value.  Telegrams: 1 - Alarm, 0 - No alarm
	CO2 value status group address	2byte type. Input group address for receiving the CO2 value from other devices on the KNX bus, and update to APP display.

### 5.12.47.3. Controlling device

There are no device control commands that can be sent.

### 5.12.47.4. Get device properties

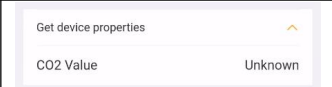
	CO2 value	Display the received status, or "Unknown" if not sure.
---	-----------	--

### 5.12.48 KNX CO sensor

Type of KNX CO sensor requires device model configuration; it supports access to KNX devices and 485 devices.

#### 5.12.48.1. Device model configuration

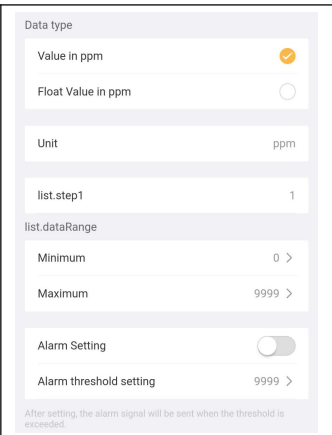
	CO data type	Set Value in ppm as the data type of CO.
		Set Float Value in ppm as the data type of CO.
	Unit	Units are displayed according to the selected data type.
	Adjustment step	Used to set the adjustment step value, it is default by 1.
	Data range	Used to set the data range of CO. The minimum value must be less than the maximum value. Optional range is 0~9999ppm.
	Alarm threshold setting	Used to set alarm threshold, optional range is 0~9999ppm but need to be in the setting value range of minimum and maximum. Once the threshold is exceeded will send an alarm telegram.

### 5.12.48.2.KNX configuration

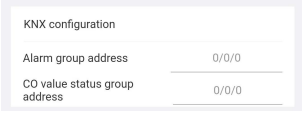
	Alarm group address	1bit type. Input group address for sending an alarm to KNX bus when CO value exceeds the setting value.  Telegrams: 1 - Alarm, 0 - No alarm
	CO value status group address	2byte type. Input group address for receiving the CO value from other devices on the KNX bus, and update to APP display.

### 5.12.48.3.Controlling device

There are no device control commands that can be sent.

### 5.12.48.4.Get device properties

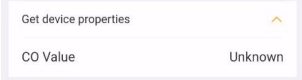
	CO value	Display the received status, or "Unknown" if not sure.
---	----------	--

### 5.12.49 KNX Formaldehyde sensor

Type of KNX Formaldehyde sensor requires device model configuration; it supports access to KNX devices, but not support to 485 interface and dry contact interface.

#### 5.12.49.1.Device model configuration

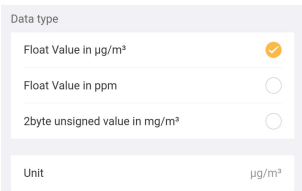
	Formaldehyde	Set Float Value in ppm as the data type of formaldehyde.
	data type	Set Float Value in ug/m3 as the data type of formaldehyde.
		Set 2byte unsigned value in mg/m3 as the data type of formaldehyde.
	Unit	Units are displayed according to the selected data type.

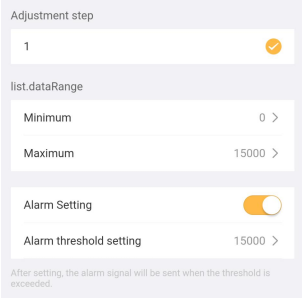
	Adjustment step	Used to set the adjustment step value, it is default by 1 when unit is ug/m3; it can be set to 0.01 or 0.1 when unit is ppm; it can be set to 0.001 or 0.01 when unit is mg/m3.
	Data range	Used to set the data range of formaldehyde. The minimum value must be less than the maximum value. Optional range is 0~15000ug/m3 / 0~20ppm / 0~15mg/m3.
	Alarm setting	Used to set whether to enable alarm function. When enabled, next settings is valid.
	Alarm threshold setting	Used to set upper limit alarm threshold, optional range is 0~15000ug/m3 / 0~20ppm / 0~15mg/m3, but need to be in the setting value range of minimum and maximum.  Once exceed threshold will send an alarm telegram.

### 5.12.49.2.KNX configuration

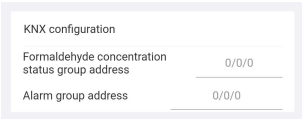
	Alarm group address	1bit type. Input group address for sending an alarm to KNX bus when formaldehyde value exceeds the setting value.  Telegrams: 1 - Alarm, 0 - No alarm
	Formaldehyde concentration status group address	2byte type. Input group address for receiving the formaldehyde value from other devices on the KNX bus, and update to APP display.

### 5.12.49.3.Controlling device

There are no device control commands that can be sent.

#### 5.12.49.4. Get device properties

	CH20	Display the received status, or "Unknown" if not sure.
--	------	--

#### 5.12.50 KNX VOC sensor

Type of KNX VOC sensor requires device model configuration; it supports access to KNX devices and 485 devices.

##### 5.12.50.1. Device model configuration

	VOC data type	Set Value in ppm as the data type of VOC. Set Float Value in ppm as the data type of VOC. Set Float Value in ug/m3 as the data type of VOC. Set 2byte unsigned value in mg/m3 as the data type of VOC.
	Unit	Units are displayed according to the selected data type.
	Adjustment step	Used to set the adjustment step value, it is default by 1 when unit is ug/m3. it can be set to 0.01 or 0.1 when unit is ppm or mg/m3.
	Data range	Used to set the data range of VOC. The minimum value must be less than the maximum value. Optional range is 0~999ug/m3 / 0~9.99ppm / 0~1mg/m3.
	Alarm setting	Used to set whether to enable alarm function. When enabled, next settings is valid.

	Alarm threshold setting	Used to set upper limit alarm threshold, optional range is 0~999ug/m3 / 0~9.99ppm / 0~1mg/m3, but need to be in the setting value range of minimum and maximum.  Once exceed threshold will send an alarm telegram.
--	-------------------------	---

### 5.12.50.2.KNX configuration

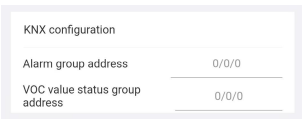
	Alarm group address	1bit type. Input group address for sending an alarm to KNX bus when VOC value exceeds the setting value.  Telegrams: 1 - Alarm, 0 - No alarm
	VOC value status group address	2byte type. Input group address for receiving the VOC value from other devices on the KNX bus, and update to APP display.

### 5.12.50.3.Controlling device

There are no device control commands that can be sent.

### 5.12.50.4.Get device properties

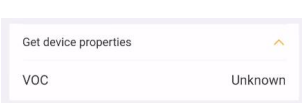
	VOC	Display the received status, or "Unknown" if not sure.
---	-----	--

### 5.12.51 KNX Brightness sensor

Type of KNX Brightness sensor requires device model configuration; it supports access to KNX devices and 485 devices.

#### 5.12.51.1.Device model configuration

	Brightness data	Set Value in Lux as the data type of brightness.
	type	Set Float Value in Lux as the data type of brightness.
	Unit	Units are displayed according to the selected data type.
	Adjustment step	Used to set the adjustment step value, it is default by 1.
	Data range	Used to set the data range of brightness. The minimum value must be less than the maximum value. Optional range is 0~99999 lux.
	Upper limit alarm setting	Used to set whether to enable upper limit alarm function. When enabled, next settings is valid.
	Alarm threshold setting	Used to set upper limit alarm threshold, optional range is 0~99999 lux, but need to be in the setting value range of minimum and maximum. Once exceed threshold will send an alarm telegram.
	Lower limit alarm setting	Used to set whether to enable lower limit alarm function. When enabled, next settings is valid.
Alarm threshold setting	Used to set lower limit alarm threshold, optional range is 0~99999 lux, but need to be in the setting value range of minimum and maximum. Once lower than threshold will send an alarm telegram.	

### 5.12.51.2.KNX configuration

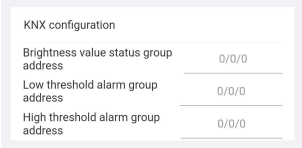
	<b>Brightness value status group address</b>	2byte type. Input group address for receiving the brightness value from other devices on the KNX bus, and update to APP display.
	<b>Low threshold alarm group address</b>	1bit type. Input group address for sending an alarm to KNX bus when brightness value is lower than the setting value.  Telegrams: 1 - Alarm, 0 - No alarm
	<b>High threshold alarm group address</b>	1bit type. Input group address for sending an alarm to KNX bus when brightness value is higher than the setting value.  Telegrams: 1 - Alarm, 0 - No alarm

### 5.12.51.3.Controlling device

There are no device control commands that can be sent.

### 5.12.51.4.Get device properties

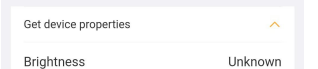
	<b>Brightness</b>	Display the received status, or "Unknown" if not sure.
---	-------------------	--

### 5.12.52 KNX Wind sensor

Type of KNX Wind sensor requires device model configuration; it supports access to KNX devices and 485 devices.

#### 5.12.52.1. Device model configuration

	Wind speed data	Set Float Value in m/s as the data type of wind speed.
	type	Set Float Value in km/h as the data type of wind speed.
	Unit	Units are displayed according to the selected data type.
	Adjustment step	Used to set the adjustment step value, it can be set to 1 or 0.1.
	Data range	Used to set the data range of wind speed. The minimum value must be less than the maximum value. Optional range is 0~50m/s / 0~183km/h.
	Alarm setting	Used to set whether to enable alarm function. When enabled, next settings is valid.
Alarm threshold setting	Used to set alarm threshold, optional range is 0~50m/s / 0~183km/h, but need to be in the setting value range of minimum and maximum.  Once the threshold is exceeded will send an alarm telegram.	

#### 5.12.52.2. KNX configuration

	Wind speed value acquisition	2byte type. Input group address for receiving the wind speed value from other devices on the KNX bus, and update to APP display.
	Alarm group address	1bit type. Input group address for sending an alarm to KNX bus when wind speed value exceeds the setting value.  Telegrams: 1 - Alarm, 0 - No alarm

### 5.12.52.3. Controlling device

There are no device control commands that can be sent.

### 5.12.52.4. Get device properties

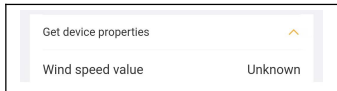
	Wind speed	Display the received status, or "Unknown" if not sure.
---	------------	--

### 5.12.53 KNX TVOC sensor

Type of KNX TVOC sensor requires device model configuration; it supports access to KNX devices and 485 devices.

#### 5.12.53.1. Device model configuration

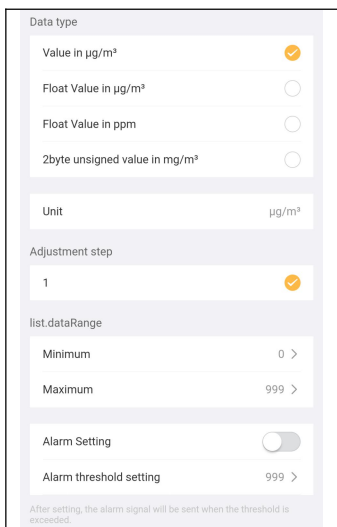
	TVOC data type	<p>Set Value in ppm as the data type of TVOC.</p> <p>Set Float Value in ppm as the data type of TVOC.</p> <p>Set Float Value in ug/m3 as the data type of TVOC.</p> <p>Set 2byte unsigned value in mg/m3 as the data type of TVOC.</p>
	Unit	Units are displayed according to the selected data type.
	Adjustment step	Used to set the adjustment step value, it is default by 1 when unit is ug/m3. it can be set to 0.01 or 0.1 when unit is ppm or mg/m3.
	Data range	Used to set the data range of TVOC. The minimum value must be less than the maximum value. Optional range is 0~999ug/m3 / 0~9.99ppm / 0~1mg/m3.
	Alarm setting	Used to set whether to enable alarm function. When enabled, next settings is valid.

	Alarm threshold setting	Used to set upper limit alarm threshold, optional range is 0~999ug/m3 / 0~9.99ppm / 0~1mg/m3, but need to be in the setting value range of minimum and maximum.  Once exceed threshold will send an alarm telegram.
--	-------------------------	---

### 5.12.53.2.KNX configuration

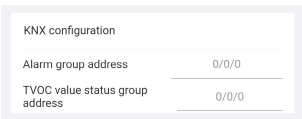
	Alarm group address	1bit type. Input group address for sending an alarm to KNX bus when TVOC value exceeds the setting value.  Telegrams: 1 - Alarm, 0 - No alarm
	TVOC value status group address	2byte type. Input group address for receiving the TVOC value from other devices on the KNX bus, and update to APP display.

### 5.12.53.3.Controlling device

There are no device control commands that can be sent.

### 5.12.53.4.Get device properties

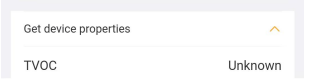
	TVOC	Display the received status, or "Unknown" if not sure.
---	------	--

### 5.12.54 Weather station

Type of weather station requires device model configuration; it supports access to KNX devices and 485 devices.

#### 5.12.54.1. Device model configuration

<p>Weather station function enable</p> <ul style="list-style-type: none"> <li>Twilight status <input checked="" type="checkbox"/></li> <li>Night status <input checked="" type="checkbox"/></li> <li>Temperature status <input checked="" type="checkbox"/></li> <li>Apparent temperature <input checked="" type="checkbox"/></li> <li>Dew point temperature status <input checked="" type="checkbox"/></li> <li>Humidity status <input checked="" type="checkbox"/></li> <li>Absolute humidity status <input checked="" type="checkbox"/></li> <li>Comfort status <input checked="" type="checkbox"/></li> <li>Brightness status <input checked="" type="checkbox"/></li> <li>Sun azimuth status <input checked="" type="checkbox"/></li> <li>Sun elevation status <input checked="" type="checkbox"/></li> <li>Wind speed <input checked="" type="checkbox"/></li> <li>Wind speed level <input checked="" type="checkbox"/></li> <li>Wind direction <input checked="" type="checkbox"/></li> <li>Pressure <input checked="" type="checkbox"/></li> <li>Frost <input checked="" type="checkbox"/></li> </ul>	Twilight status	Used to set whether to enable twilight status function. When enabled, "twilight status data type" is valid.
	Night status	Used to set whether to enable night status function. When enabled, "night status data type" is valid.
	Temperature status	Used to set whether to enable temperature status function.
	Apparent temperature	Used to set whether to enable apparent temperature function.
	Dew point	Used to set whether to enable dew point temperature status function.
	Humidity status	Used to set whether to enable humidity status function.
	Absolute humidity status	Used to set whether to enable absolute humidity status function. When enabled, "absolute humidity status data type" is valid.
	Comfort status	Used to set whether to enable comfort status function. When enabled, "comfort status data type" is valid.
	Brightness status	Used to set whether to enable brightness status function.
	Sun azimuth status	Used to set whether to enable sun azimuth status function. When enabled, "sun azimuth status data type" is valid.
	Sun elevation status	Used to set whether to enable sun elevation status function. When enabled, "sun elevation status data type" is valid.
	Wind speed	
	Wind speed level	
	Wind direction	

	Wind speed	Used to set whether to enable wind speed function.	
	Wind speed level	Used to set whether to enable wind speed level function.	
	Wind direction	Used to set whether to enable wind direction function.	
	Pressure	Used to set whether to enable pressure function.	
	Frost	Used to set whether to enable frost function. When enabled, "frost data type" is valid.	
<div style="border: 1px solid #ccc; padding: 5px;"> <p><b>Twilight status</b>Data type</p> <p>0 activated; 1 deactivated <input type="radio"/></p> <p>1 activated; 0 deactivated <input checked="" type="radio"/></p> </div> <div style="border: 1px solid #ccc; padding: 5px; margin-top: 5px;"> <p><b>Night status</b>Data type</p> <p>0 activated; 1 deactivated <input checked="" type="radio"/></p> <p>1 activated; 0 deactivated <input type="radio"/></p> </div> <div style="border: 1px solid #ccc; padding: 5px; margin-top: 5px;"> <p><b>Absolute humidity status</b>Data type</p> <p>14.005 amplitude g/kg <input type="radio"/></p> <p>9.*2-byte float value g/m<sup>3</sup> <input checked="" type="radio"/></p> </div> <div style="border: 1px solid #ccc; padding: 5px; margin-top: 5px;"> <p><b>Comfort status</b>Data type</p> <p>0 activated; 1 deactivated <input type="radio"/></p> <p>1 activated; 0 deactivated <input checked="" type="radio"/></p> </div> <div style="border: 1px solid #ccc; padding: 5px; margin-top: 5px;"> <p><b>Sun azimuth status</b>Data type</p> <p>14.007 angle (degree) <input type="radio"/></p> <p>9.*2-byte float value <input checked="" type="radio"/></p> </div> <div style="border: 1px solid #ccc; padding: 5px; margin-top: 5px;"> <p><b>Sun elevation status</b>Data type</p> <p>14.007 angle (degree) <input type="radio"/></p> <p>9.*2-byte float value <input checked="" type="radio"/></p> </div> <div style="border: 1px solid #ccc; padding: 5px; margin-top: 5px;"> <p><b>Frost</b>Data type</p> <p>0 activated; 1 deactivated <input type="radio"/></p> <p>1 activated; 0 deactivated <input checked="" type="radio"/></p> </div>	Twilight status data type	Set 0 activated; 1 deactivated as the telegram of twilight status.	
			Set 1 activated; 0 deactivated as the telegram of twilight status.
		Night status data type	Set 0 activated; 1 deactivated as the telegram of night status.
			Set 1 activated; 0 deactivated as the telegram of night status.
		Absolute humidity status data type	Set "14.005 amplitude g/kg" as the data type of absolute humidity status.
			Set "9.*2-byte float value g/m <sup>3</sup> " as the data type of absolute humidity status.
		Comfort status data type	Set 0 activated; 1 deactivated as the telegram of comfort status.
			Set 1 activated; 0 deactivated as the telegram of comfort status.
		Sun azimuth status data type	Set "14.007 angle(degree)" as the data type of absolute humidity status.
			Set "9.*2-byte float value" as the data type of absolute humidity status.
	Sun elevation status	Set "14.007 angle(degree)" as the data type of absolute	

	data type	humidity status.
		Set "9.*2-byte float value" as the data type of absolute humidity status.
	Frost data type	Set 0 activated; 1 deactivated as the telegram of frost.
		Set 1 activated; 0 deactivated as the telegram of frost.

### 5.12.54.2.KNX configuration

<div style="border: 1px solid black; padding: 5px;"> <p>KNX configuration</p> <p>Twilight status <input type="checkbox"/> 0/0/0</p> <p>Night status <input type="checkbox"/> 0/0/0</p> <p>Temperature status <input type="checkbox"/> 0/0/0</p> <p>Apparent temperature status <input type="checkbox"/> 0/0/0</p> <p>Dew point temperature status <input type="checkbox"/> 0/0/0</p> <p>Humidity status <input type="checkbox"/> 0/0/0</p> <p>Absolute humidity status <input type="checkbox"/> 0/0/0</p> <p>Comfort status <input type="checkbox"/> 0/0/0</p> <p>Brightness status <input type="checkbox"/> 0/0/0</p> <p>Sun azimuth status <input type="checkbox"/> 0/0/0</p> <p>Sun elevation status <input type="checkbox"/> 0/0/0</p> <p>Wind speed <input type="checkbox"/> 0/0/0</p> <p>Wind speed level <input type="checkbox"/> 0/0/0</p> <p>Wind direction <input type="checkbox"/> 0/0/0</p> <p>Pressure <input type="checkbox"/> 0/0/0</p> <p>Frost <input type="checkbox"/> 0/0/0</p> </div>	Twilight status	1bit type. Input group address for receiving the twilight status value from other devices on the KNX bus, and update to APP display. The telegram value is defined by the "twilight status data type".
	Night status	1bit type. Input group address for receiving the night status value from other devices on the KNX bus, and update to APP display. The telegram value is defined by the "night status data type".
	Temperature status	2byte type. Input group address for receiving the temperature status value from other devices on the KNX bus, and update to APP display. Optional range is -50~80°C
	Apparent temperature	2byte type. Input group address for receiving the apparent temperature value from other devices on the KNX bus, and update to APP display. Optional range is -50~80°C
	Dew point Temperature status	2byte type. Input group address for receiving the dew point temperature status value from other devices on the KNX bus, and update to APP display. Optional range is -50~80°C
	Humidity status	2byte type. Input group address for receiving the humidity status

		value from other devices on the KNX bus, and update to APP display. Optional range is 0~100%
Absolute humidity status		2byte type. Input group address for receiving the absolute humidity status value from other devices on the KNX bus, and update to APP display. Optional range is 0~999g/m <sup>3</sup>
Comfort status		1bit type. Input group address for receiving the comfort status value from other devices on the KNX bus, and update to APP display. The telegram value is defined by the "comfort status data type".
Brightness status		2byte type. Input group address for receiving the brightness status value from other devices on the KNX bus, and update to APP display. Optional range is 0~100000Lux
Sun azimuth status		2byte type. Input group address for receiving the sun azimuth status value from other devices on the KNX bus, and update to APP display. Optional range is 0~360°
Sun elevation status		2byte type. Input group address for receiving the sun elevation status value from other devices on the KNX bus, and update to APP display. Optional range is 0~90°
Wind speed		2byte type. Input group address for receiving the wind speed value from other devices on the KNX bus, and update to APP display.
Wind speed level		1byte type. Input group address for receiving the wind speed level from other devices on the KNX bus, and update to APP display.
Wind direction		1bit type. Input group address for receiving the wind direction from other devices on the KNX bus, and update to APP display.

	Pressure	2byte type. Input group address for receiving the pressure value from other devices on the KNX bus, and update to APP display.  Optional range is 95000~105000Pa
	Frost	1bit type. Input group address for receiving the frost status value from other devices on the KNX bus, and update to APP display.  The telegram value is defined by the "frost status data type".

### 5.12.54.3. Controlling device

There are no device control commands that can be sent.

### 5.12.54.4. Get device properties

	Temperature status	Display the received temperature status, or "Unknown" if not sure.
	Relative humidity	Display the received relative humidity status, or "Unknown" if not sure.
	Brightness status	Display the received brightness status, or "Unknown" if not sure.
	Twilight status	Display the received twilight status, or "Unknown" if not sure.
	Night status	Display the received night status, or "Unknown" if not sure.
	Frost	Display the received frost status, or "Unknown" if not sure.
	Comfort status	Display the received comfort status, or "Unknown" if not sure.
	Apparent temperature	Display the received apparent temperature status, or "Unknown" if not sure.
	Dew point temperature	Display the received dew point temperature status, or "Unknown" if not sure.
	Absolute humidity	
	Sun azimuth	
	Sun elevation	

	Absolute humidity	Display the received absolute humidity status, or "Unknown" if not sure.
	Sun azimuth	Display the received sun azimuth status, or "Unknown" if not sure.
	Sun elevation	Display the received sun elevation status, or "Unknown" if not sure.
	Pressure	Display the received pressure status, or "Unknown" if not sure.
	Wind level	Display the received wind level status, or "Unknown" if not sure.
	Wind direction	Display the received wind direction status, or "Unknown" if not sure.
	Wind speed	Display the received wind speed status, or "Unknown" if not sure.

### 5.12.55 Legrand 13 screen

Type of legrand 13 screen requires device model configuration; it supports access to 485 devices, but not support to KNX interface and dry contact interface. Gateway sub-devices can be synchronized and displayed on the legrand 13 screen.

The configuration steps are as follows:

1. After configuring the devices on the legrand 13 screen, provide the correspondence between devices and A/PL.
2. In GVS smart assistant app, select the devices to be synchronized to the rogerland 13 screen, and associate each device with the correct A/PL address.
3. The configuration takes effect after being deployed to the gateway.

**Note:** This function supports legrand protocol V1.12.

#### 5.12.55.1.Device model configuration

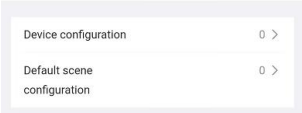
	Device configuration	Used to associate the device of the APP.  <i>Note: Only support switch, brightness adjustment, curtain position, Air conditioner, central ventilation system, floor heating, integrated environmental sensor.</i>
	Default scene configuration	Used to associate the default scenes of the APP.

#### 5.12.55.2.KNX configuration

There are no KNX objects that can be configured.

#### **5.12.55.3. Controlling device**

There are no device control commands that can be sent.

#### **5.12.55.4. Get device properties**

There are no device status that can be received.

## Chapter 6 KNX Engineering Assistant Management Platform

### 6.1 Summary

The login address of KNX Engineering Assistant Management Platform is

<https://assistant.gvs-icloud.com/#/> and the login page is shown below.

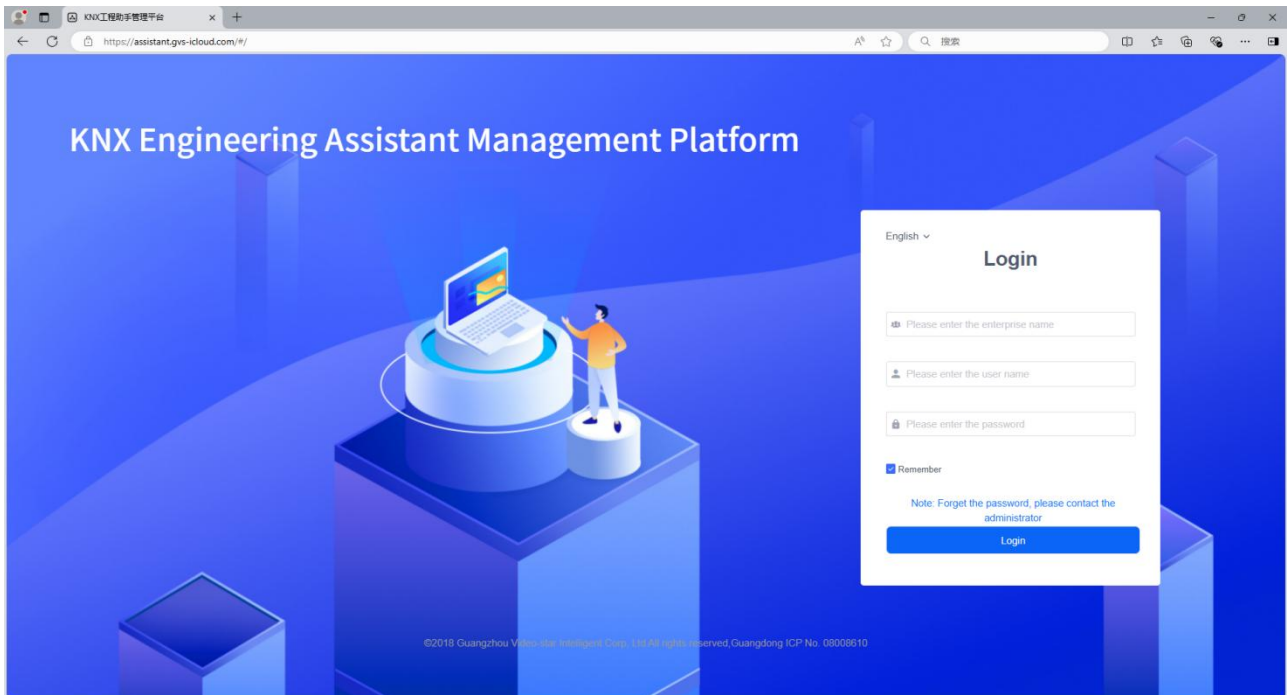

Login page

KNX Engineering Assistant Management Platform is a background management system that assists Multifunctional Gateway in debug project.

Use the corporate administrator account or the engineer's account to log in, it is mainly used for the management of projects belonging to the corporate, engineer management, equipment management, project template management, deletion record management and use feedback. And you can view the details of the project configuration under the specific project.

**The corporate administrator account and initial password are obtained from the system administrator, it is created by the system administrator.**

## 6.2 Enterprise Management Client

### 6.2.1 Login

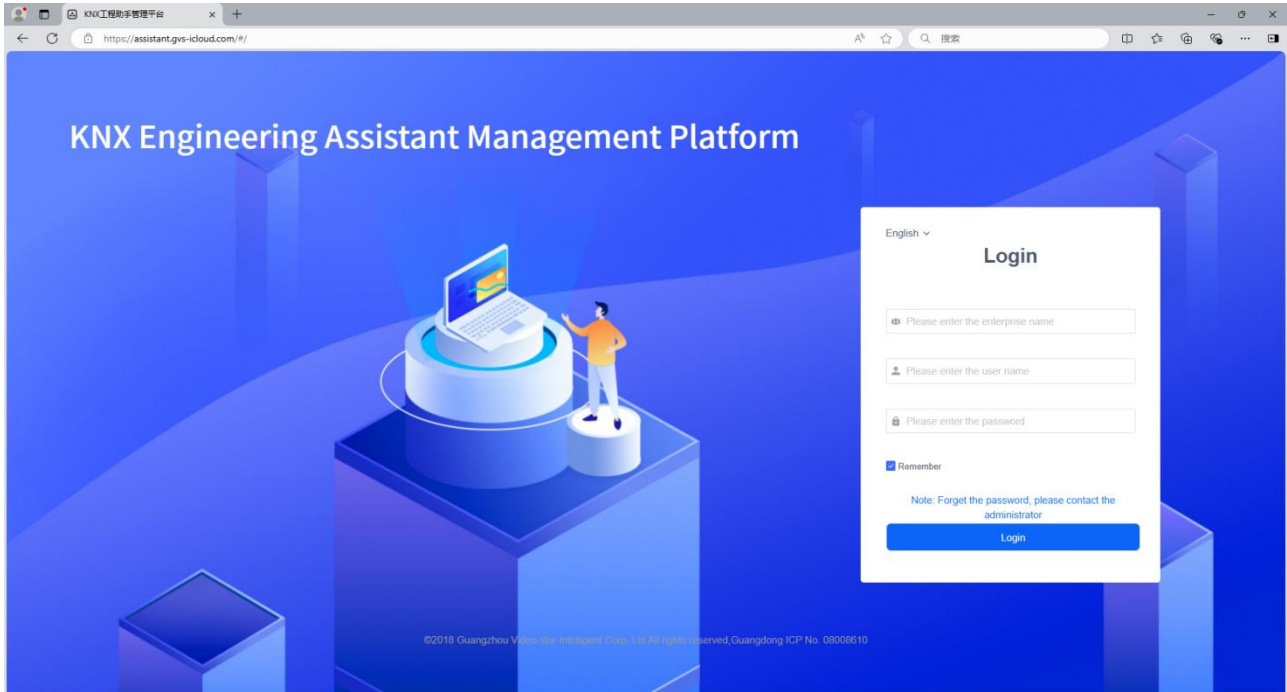

Fig.6.2.1.1Login window

Input correct enterprise name, user name and password to login

It will pop up a dialog box that prompts you need to change your password when firstly login, as shown as following figure. In order to ensure the security of the account, it is mandatory to change the initial password, if cancel change and will return the login window.

If you forget your password, please contact the system administrator.

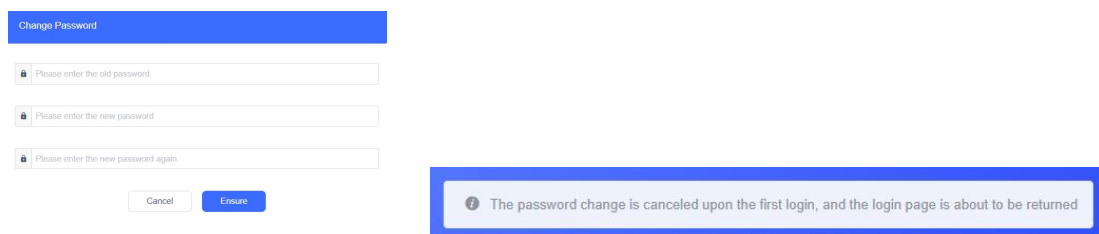

Fig.6.2.1.2Password change

## 6.2.2 Home

Home page shows an overview, including number of projects, engineers and devices, enterprise name, enterprise code, account status and etc.

It provides the password change and logout in the upper right corner of the interface.

The navigation bar on the left of home page, Enterprise administrator can open the interfaces of project management, engineer management, device management and others to edit or view. Operation of each management interface is described in following chapters.

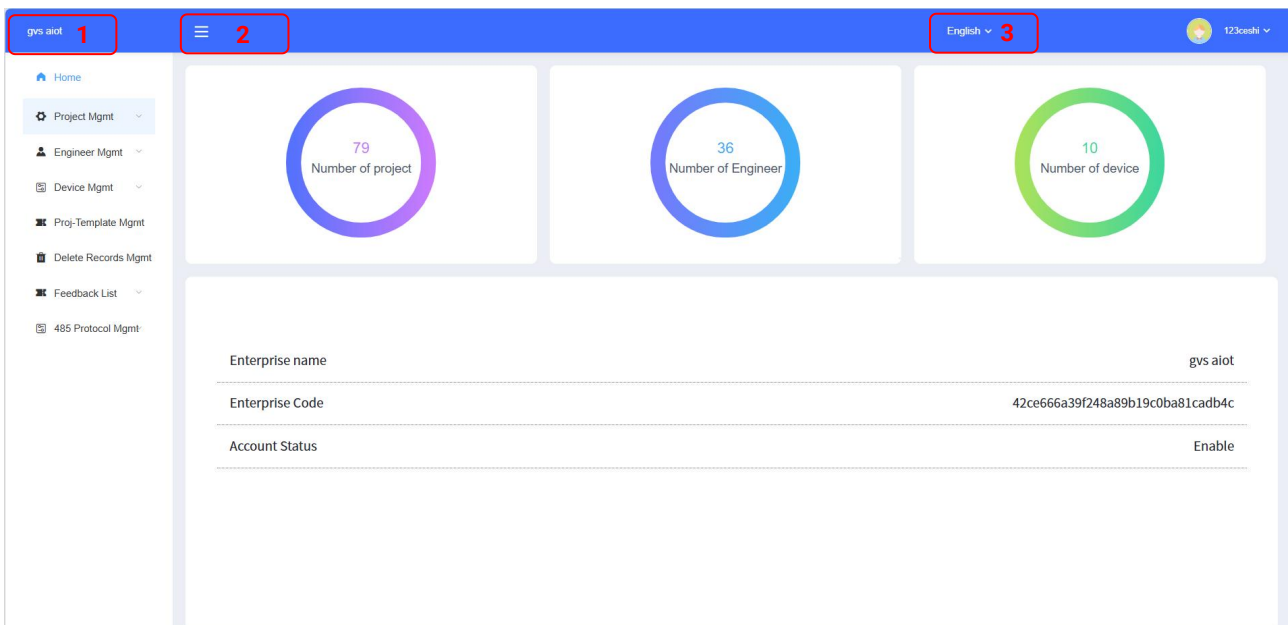

Fig.6.2.2.1 Home page of enterprise management

- (1) Display the enterprise name.
- (2) Set navigation bar hidden or display.
- (3) Set the language of platform, support Chinese and English.

### 6.2.3 Project management

The project management interface displays all projects under the current enterprise. These projects can be established on this platform or on the "GVS Smart assistant" APP.

Interface of project management is shown as Fig.6.2.3.1, you can add, delete, view, search and sort the projects.

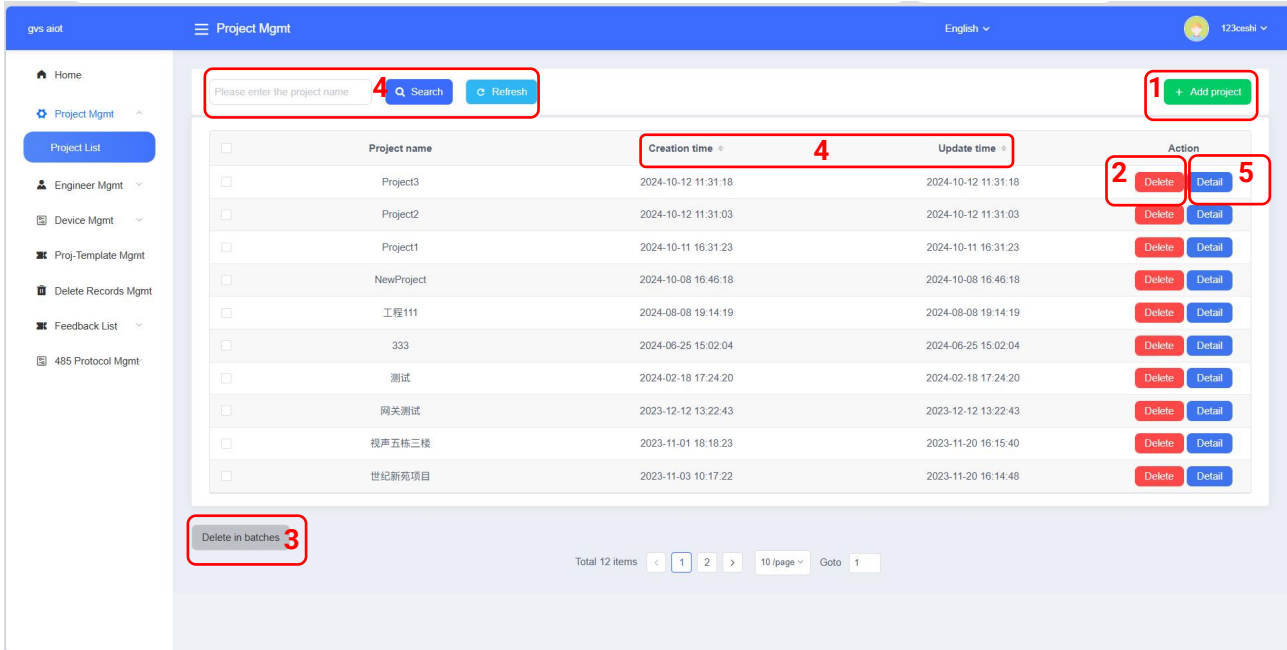

Fig.6.2.3.1 Project management

The instructions for the items in the figure are as follows:

#### (1) Add project

Click "+ Add project" button, pop up a window as shown as Fig.6.2.3.2, enter project name in the window, and the operation is successful after clicking "Ensure", the new created project is added to the project list.

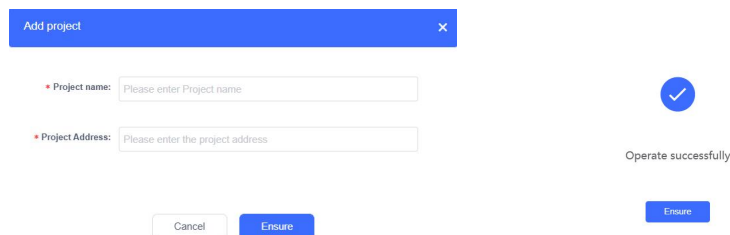

Fig.6.2.3.2 Add new project

Project name: 1-30 characters, all blank strings are prohibited.

Project address: all blank strings are prohibited.

## (2)Delete

Click “Delete” on the interface of project management, pop up a window as following figure, click “Delete” button and the buildings, devices and other configuration in this project are deleted synchronously.

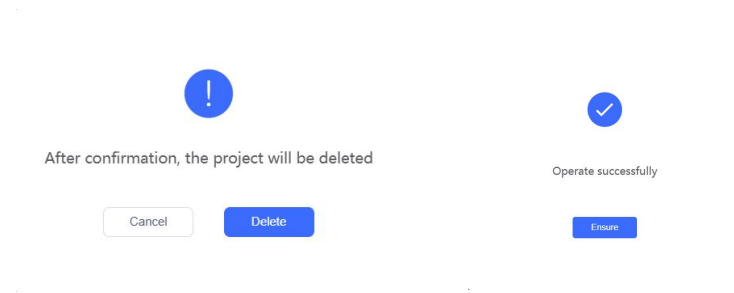

Fig.6.2.3.3 Delete project

## (3)Delete in batches

Choose multiple projects and delete together.

## (4)Search&Sort

- ①Search: support fuzzy search of keywords, such as project name.
- ②Refresh: refresh the interface display when there is update.
- ③Sort: sort with creation time or update time.

(5)Detail

Click “Detail” on the interface of project management, you can view the detail information of project, as show as Fig.6.2.3.4.

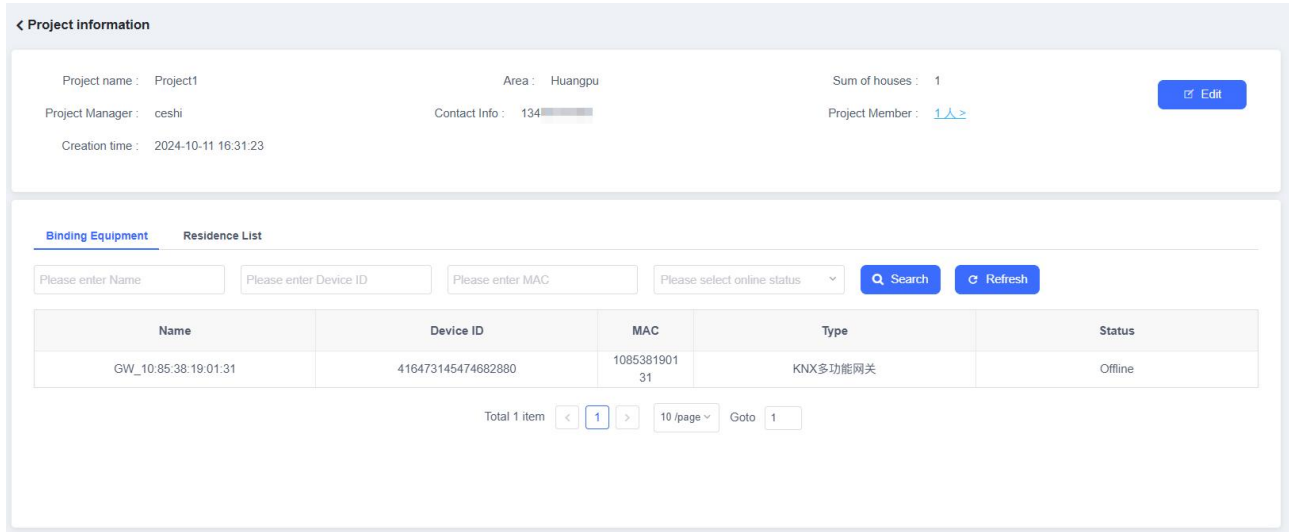
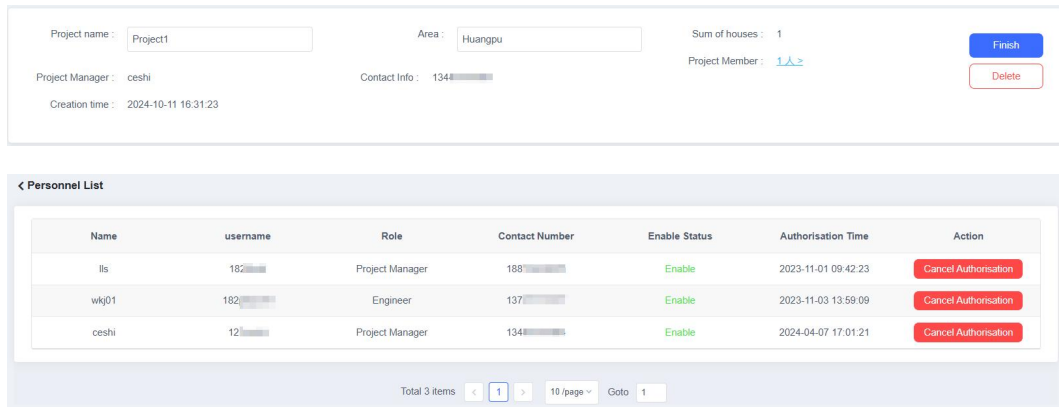

Fig.6.2.3.4 Project detail

View or edit project information, device list and building list (also included detail of buildings).

①Edit project information



Edit project information and cancel authorization

❖Project name: allow to modify the project name.

❖Area: allow to modify the area the project belong to.

- ❖Project Manager, Contact Info: display the name of the project manager who created the project, and his contact information.
- ❖Sum of houses : display the number of buildings that have been uploaded to the cloud by this project in APP.
- ❖Project Member : display the number of authorized engineers for this project. After clicking, you can view the account information of the person list. After operate "Cancel Authorisation", the member will be canceled to get the permission to synchronize and modify the cloud project, and for the project that has been downloaded locally, some operations will be prohibited, such as configuration file download and gateway re-connection.
- ❖Delete : operate to delete the project. After successful deletion, the page jumps to the project management interface, and the corresponding project in the list is deleted.

## ②View binding device

Binding Equipment Residence List

Please enter Name Please enter Device ID Please enter MAC Please select online status Search Refresh

Name	Device ID	MAC	Type	Status
GW_10:85:38:19:01:31	416473145474682880	108538190131	KNX多功能网关	Offline

Total 1 item 1 10/page Goto 1

### Binding Equipment list

Display all devices bound to the project, and view the basic information of each device, such as device name, device ID, MAC address, and online status.

## ③View building

Binding Equipment Residence List

Please enter building name or building number Please input house name or house number Please enter the gateway SN code Please enter MAC Please select online status Search Refresh

	Building Name	House Name	Gateway ID	Gateway MAC	Device Type	Status	Audit Status	Action
<input type="checkbox"/>	Building1	Room1	416473145474682880	108538190131	KNX多功能网关		---	<a href="#">Delete</a> <a href="#">Detail</a>

Delete in batches Batch Audit

Total 1 item 1 10/page Goto 1

### Residence List

Display all the buildings of the project, you can view the basic information, such as building name, room name, device ID, MAC address of the bound gateway, online status, and the audit status of the configuration file (pending audit, audited, and in the configuration is displayed with "---").

You can also delete, batch delete and batch audit the buildings in the list. Click the "Details" button behind the list of buildings to enter the detail page.

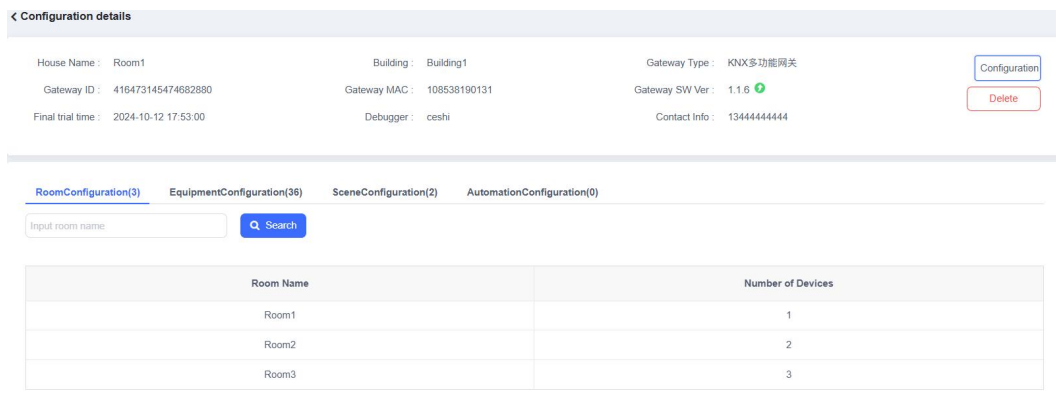

### Residence detail

The building details display the basic information and the status of bound gateway, and also allow to view the Room Configuration, Device Configuration, Scene Configuration, and Automation Scene Configuration.

You can change the review status of the configuration file in this interface: [To be reviewed](#), [Audited](#), [Configuring](#), and you can also perform the delete operation.

Note: creating and editing building files, as well as binding devices are all operated in "GVS Smart Assistant" App, please refer to [Chapter 5](#) for details. In addition, this interface can display the current version of the gateway, and you can update version to the gateway as follows:

Click icon  , the version selection window will pop up, select the version you need to upgrade, and confirm to upgrade:

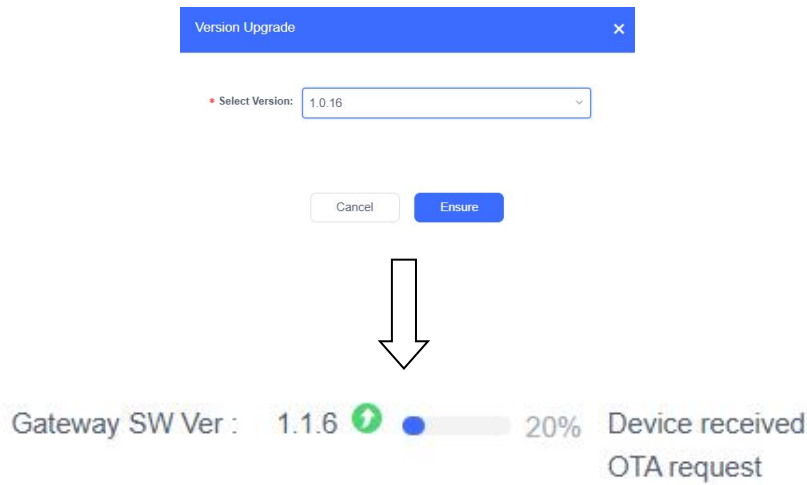

**Note:**

**Before upgrading, make sure the gateway is online.**

**During the upgrade process, you cannot close the webpage or disconnect the gateway, otherwise the upgrade will failure. During the upgrade process, if the pushed version is the same as the current version of the device, the device will not be upgraded and the upgrade process will be skipped directly.**

**After the upgrade is successful, refresh the interface to view the device version information on the platform.**

**If the upgrade fails, the current version will be displayed.**

### 6.2.4 Engineer management

Interface of engineer management is shown as Fig.6.2.4.1, you can add, delete, view, search and sort engineer, as well as authorize device to engineers.

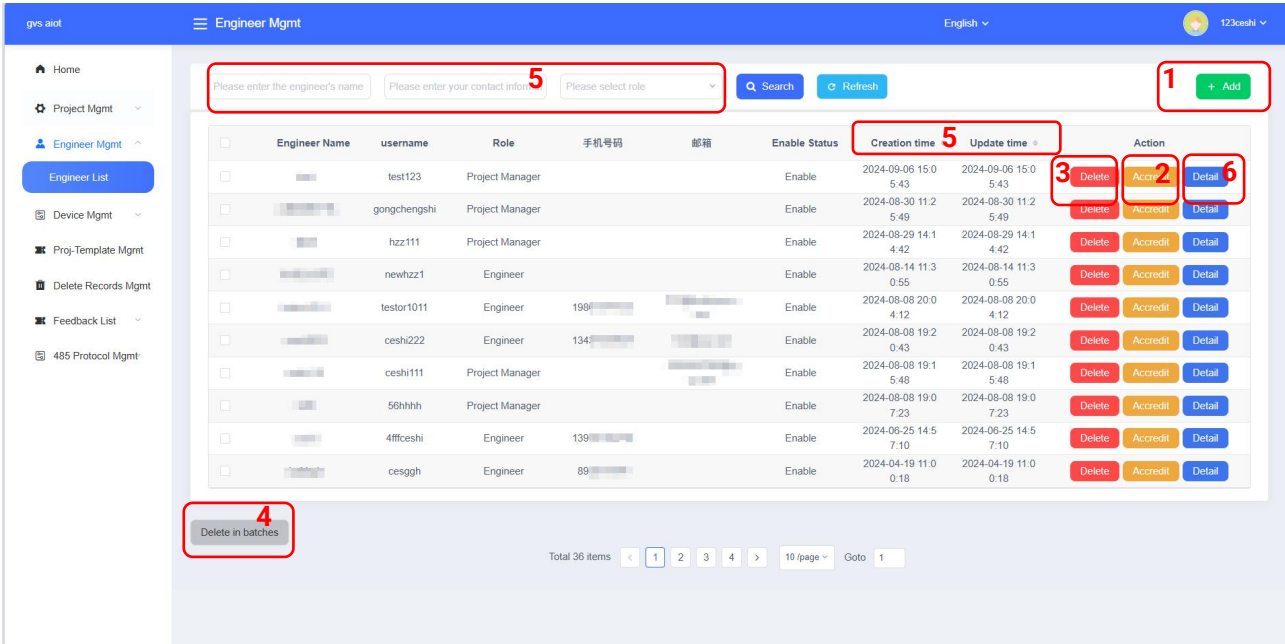

Fig.6.2.4.1 Engineer management

The instructions for the items in the figure are as follows:

#### (1) Add engineer

Click “+ Add” button, pop up a window as shown as Fig.6.2.4.1, enter engineer user name, name of engineer, contact information and role in the window, as well as add remark.

Upon correct operation, a pop-up window prompts you with a randomly generated initial account information for platform and APP, including user name and password, you can copy this information directly and send it to the appropriate team member. At the same time, the newly created engineer is added to the engineer list.

The image shows two screenshots from a web application. The left screenshot is a form titled 'Add' with a close button (X) in the top right corner. It contains several input fields: 'Engineer username' (with a red asterisk), 'Name of engineer' (with a red asterisk), 'Engineer Role' (with a red asterisk and a dropdown arrow), 'Contact Number', 'Email', and 'Remark'. Each field has a placeholder text: 'Please enter the engineer user name', 'Please enter the engineer's name', 'Please select role', 'Please enter a contact number', 'Please enter your contact information', and 'Please enter remarks'. At the bottom of the form are two buttons: 'Cancel' and 'Ensure'. The right screenshot is a 'Hint' message box with a close button (X) in the top right corner. It contains the text 'Operate successfully' followed by a list of details: 'Enterprise name: gvs aiot', 'username: Engineer1', 'initial password: l294FO1u', 'Phone number:', 'Email:', and 'Web page address: https://assistant.gvs-icloud.com'. At the bottom of the hint box is a blue 'Copy' button.

Fig.6.2.4.2 Add new engineer

Engineer user name: 6-50 characters in English or a combination of English and digit, - is allowed.

After adding, it cannot be changed, and the name cannot be repeated, otherwise it cannot be added.

Name of engineer: 1-50 characters, all blank strings are prohibited.

Contact Number: enter a cell phone number that can be used. The number cannot be duplicated, otherwise it cannot be added.

Engineer Role: two engineer roles can be created, Project Manager and Engineer.

Role authority: Project Manager > Engineer.

Engineer role can only log in APP, can not log in platform; while corporate administrator/project manager has all the operation rights.

Remark (optional): 0-200 characters, all blank strings are prohibited.

## (2)Authorization

Click "Accredit" in the engineer management interface to enter the authorization interface as shown in Fig.6.2.4.2 below, select "Engineering AUZ", you can authorize one or more projects to the team member, or release the authorization relationship between these projects and the team member.

After authorization, engineers can use the "GVS Smart Assistant" APP to configure the project.

This operation is generally only used to authorize projects to team members with the role of "Engineer"; corporate administrator/project managers do not need to authorize and can manage all projects.

The "Equipment AUZ" in the following interface is invalid for KNX Multifunction Gateway, and this operation is not described in detail..

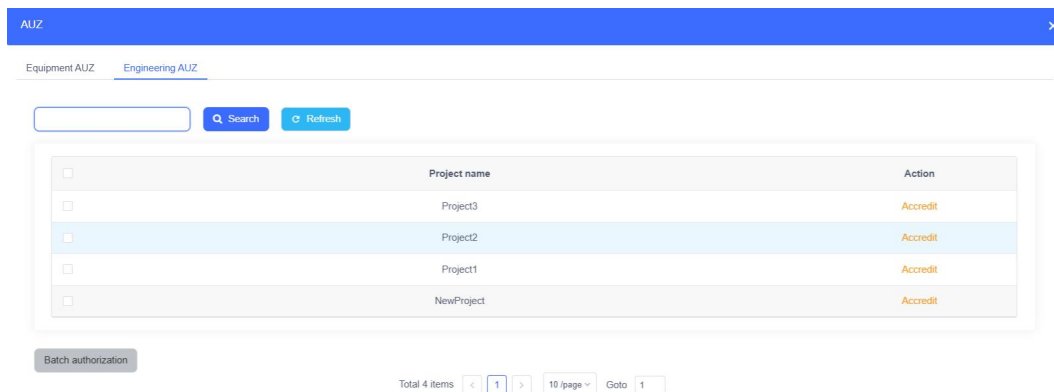

Fig.6.2.4.2 Authorization project

## (3)Delete

Click "Delete" on the interface of engineer management, pop up a window as following figure, click "Delete" button and the authorization relationship between the engineer and the projects is deleted synchronously, and the person will no longer be able to log in to the platform and the "GVS Smart Assistant" APP.

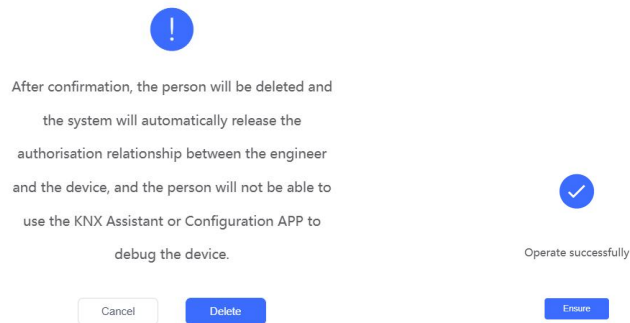

Fig.6.2.4.3 Delete engineer

Cannot delete corporate administrator, no such operation privilege.

#### (4)Delete in batches

Choose multiple engineers and delete together.

#### (5)Search&Sort&Refresh

- ①Search: support fuzzy search of keywords, such as user name, name, phone number or email address.
- ②Select the account status ( Enable / Disable ).
- ③Refresh: refresh the interface display when there is update.
- ④Sort: sort with creation time or update time.

(6)Detail

Click "Details" in the engineer management interface to view detailed engineer information, as shown in Fig.6.2.4.4.

You can edit and view basic engineer information, as well as edit and view authorized projects.

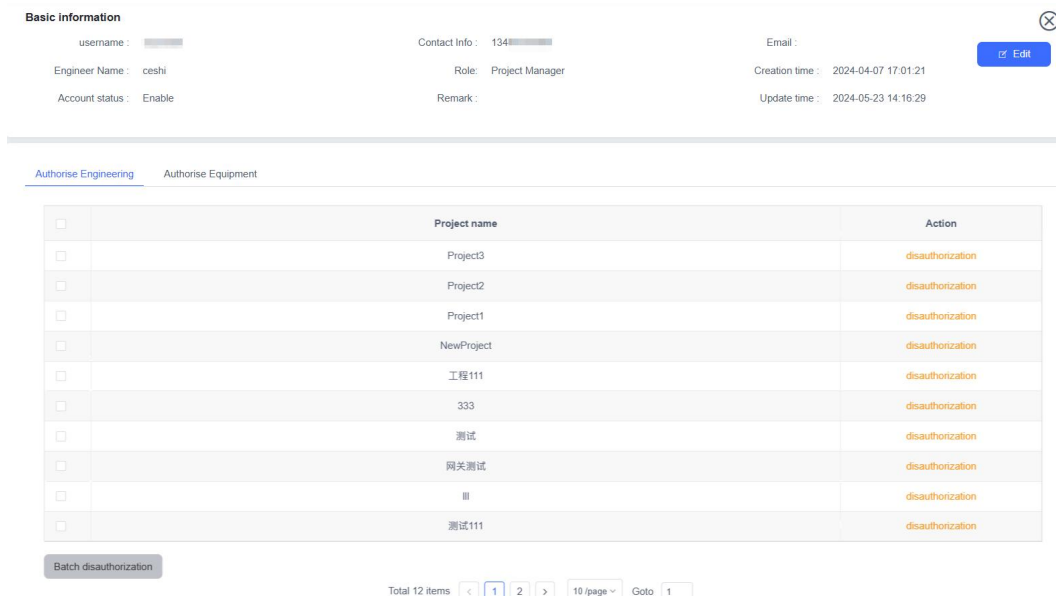
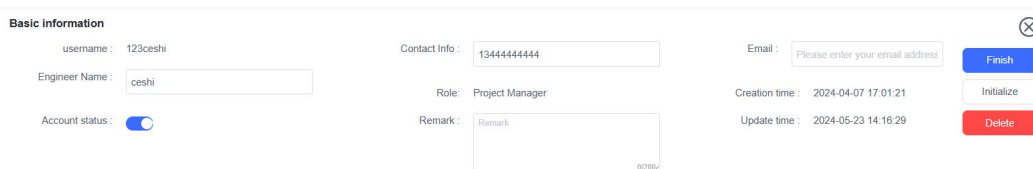

Fig.6.2.4.4 Engineer detail

①Edit basic information



Edit basic information of engineer

- ❖ Engineer Name: allow to modify.
- ❖ Account status: Enable / Disable.
- ❖ Contact Info: allow to modify.
- ❖ Role: allow to modify role as project manager or engineer.
- ❖ Remark: you can add a remark.
- ❖ Delete: delete this engineer. Jump to the interface of engineer management after successful delete, and corresponding engineer in the list is also deleted.

❖Initialize: enterprise administrator / project manager can initialize the login password of engineer.

## ②Cancel Authorization

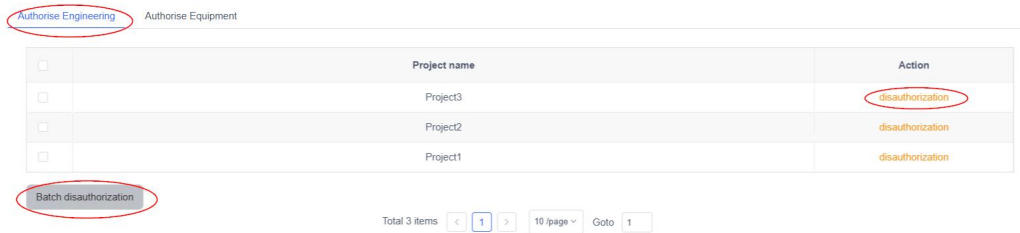

### Authorization project

❖Disauthorization: in the project authorization window, click "Disauthorization", prompting successful operation, you can unauthorize successfully. Then engineers can no longer download or modify the cloud files of the project through the "GVS Smart Assistant" APP, so please be careful with the operation!

❖Disauthorization in batches: choose multiple projects and unauthorize together.

### 6.2.5 Device management

The device management interface is shown in Fig.6.2.5.1 below, which displays all the bound devices under the current enterprise, and allows viewing, upgrading, and deleting operations.

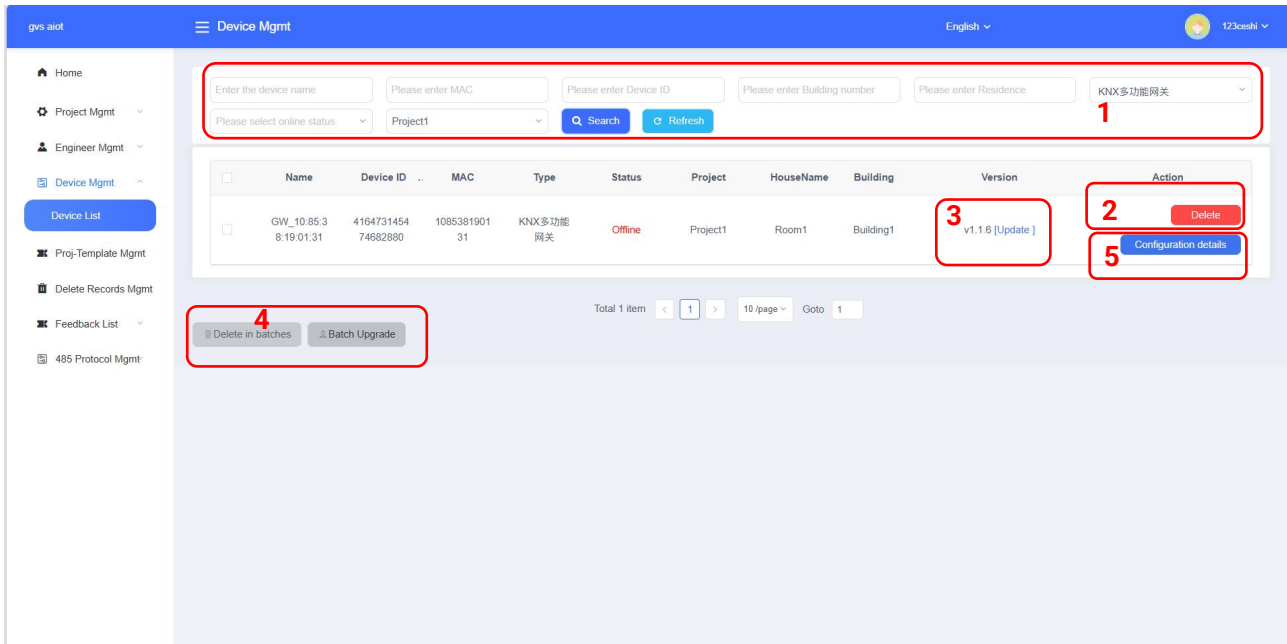

Fig.6.2.5.1 Device management

The instructions for the items in the figure are as follows:

#### (1) Search&Sort&Refresh

- ① Search: support search of keywords, such as device name, device ID, MAC address, building information.
- ② Select the device online status ( Online / Offline ), the project belongs to, device type.
- ③ Refresh: refresh the interface display when there is update.

(2)Delete

Click "Delete" in the device management interface, the window shown in figure below will pop up, confirm to delete.

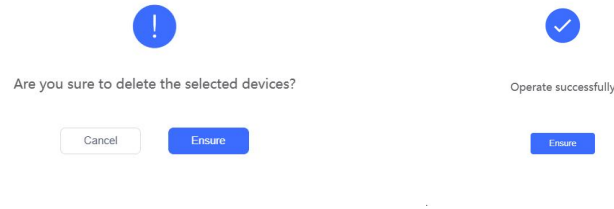



Fig.6.2.4.1 Delete device

The deletion operation only deletes the device information from the platform, which will not affect the associated projects or the connection status between the "GVS Smart Assistant" APP and the device.

If you download the cloud file to the "GVS Smart Assistant" APP for the first time after deletion, the gateway information of the device will be missing on the APP, and the information can only be obtained after rebinding.

If the platform needs to obtain the device information again, just upload it again from the "GVS Smart Assistant" APP.

(3)Version update

Click icon  , the version selection window will pop up, select the version you need to upgrade, and confirm to upgrade:

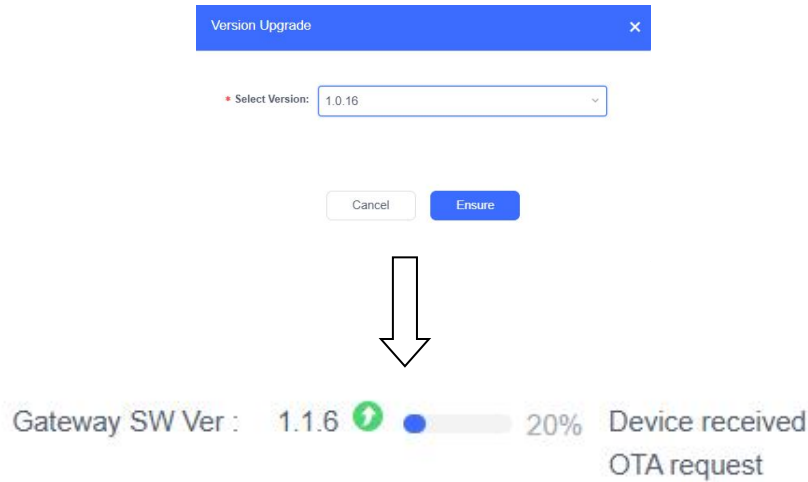

Fig.6.2.5.3 Version update

**Note:**

**Before upgrading, make sure the gateway is online.**

**During the upgrade process, you cannot close the webpage or disconnect the gateway, otherwise the upgrade will failure. During the upgrade process, if the pushed version is the same as the current version of the device, the device will not be upgraded and the upgrade process will be skipped directly.**

**After the upgrade is successful, refresh the interface to view the device version information on the platform.**

**If the upgrade fails, the current version will be displayed.**

(4)Delete in batches&Update in batches

Choose multiple devices and delete or update together.

(5)Detail

**< Configuration details**

House Name : Room1      Building : Building1      Gateway Type : KNX多功能网关      [Configuration](#)  
 Gateway ID : 416473145474682880      Gateway MAC : 108538190131      Gateway SW Ver : 1.1.6 ✔      [Delete](#)  
 Final trial time : 2024-10-12 17:53:00      Debugger : ceshi      Contact info : 13444444444

---

[RoomConfiguration\(3\)](#)   [EquipmentConfiguration\(36\)](#)   [SceneConfiguration\(2\)](#)   [AutomationConfiguration\(0\)](#)

Input room name:  [Search](#)

Room Name	Number of Devices
Room1	1
Room2	2
Room3	3

Fig.6.2.5.4 Device detail

Click "Details" on the device management interface to open the details interface, where you can view gateway information, debugger and contact information, and configuration file information.

You can upgrade the gateway firmware version, change the status of the configuration file (To be reviewed/Audited/Configuring) on this interface, or delete the device.

### 6.2.6 Project template management

The project template management interface, shown in Fig.6.2.6.1 below, displays configuration templates for all projects under the enterprise. The templates can be invoked during building configuration to save time.

The template can be deleted, viewed and searched in the current interface.

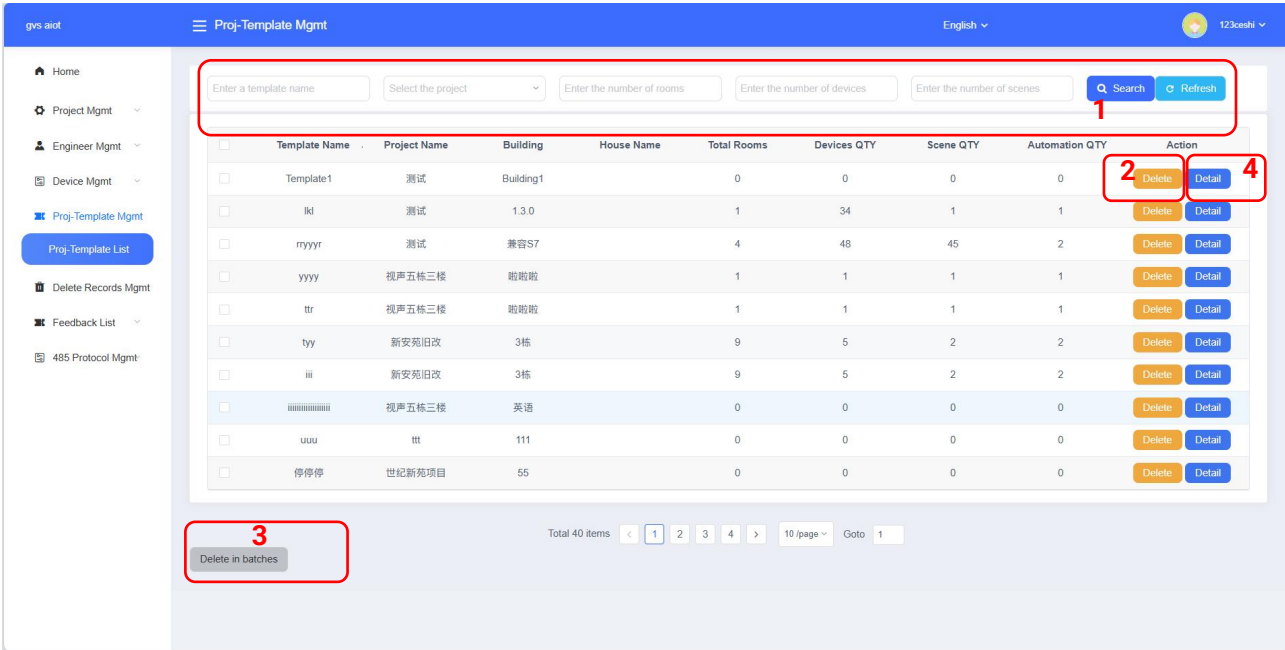

Fig.6.2.6.1 Template management

The instructions for the items in the figure are as follows:

#### (1) Search&Sort&Refresh

- ① Search: support search of keywords, such as template name, the number of rooms, the number of devices, the number of scenes.
- ② Select the project belongs to.
- ③ Refresh: refresh the interface display when there is update.

(2)Delete

Click "Delete" in the template management interface, the window shown in figure below will pop up, confirm to delete.

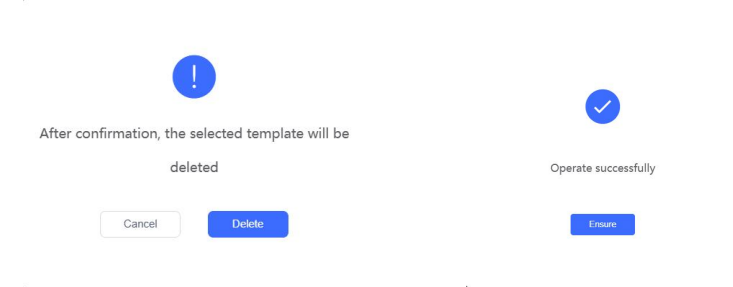

Fig.6.2.4.2 Delete template

(3)Delete in batches

Choose multiple templates and delete together.

(4)Detail

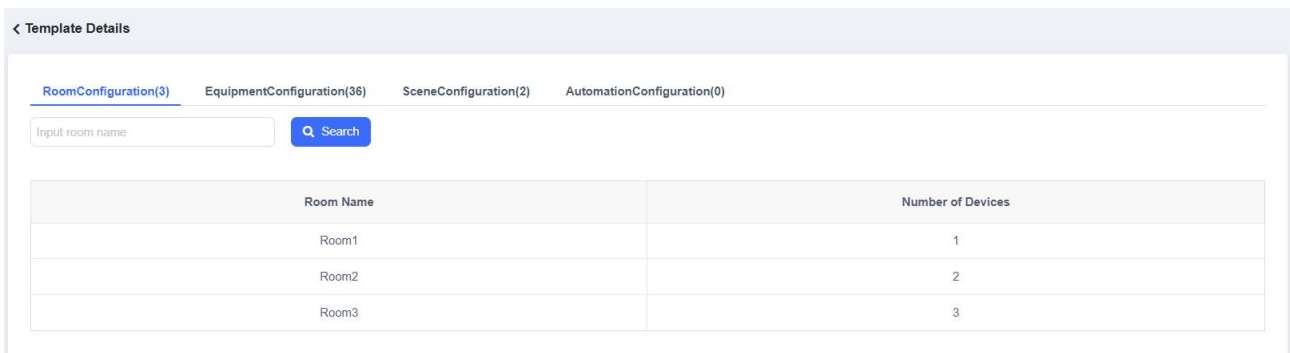

Fig.6.2.6.3 Template detail

Click "Details" in the project template management interface to view the configuration information of the template: Room Configuration, Device Configuration, Scene Configuration, and Automation Configuration.

### 6.2.7 Delete record management

Deleted records management interface is shown in Fig.6.2.7.1 below, you can view the deleted records of projects and devices, and support the operations of restoring and viewing details.

By default, you can only view the records deleted in the last six months, please contact GVS to confirm whether you can view or restore the records before six months.

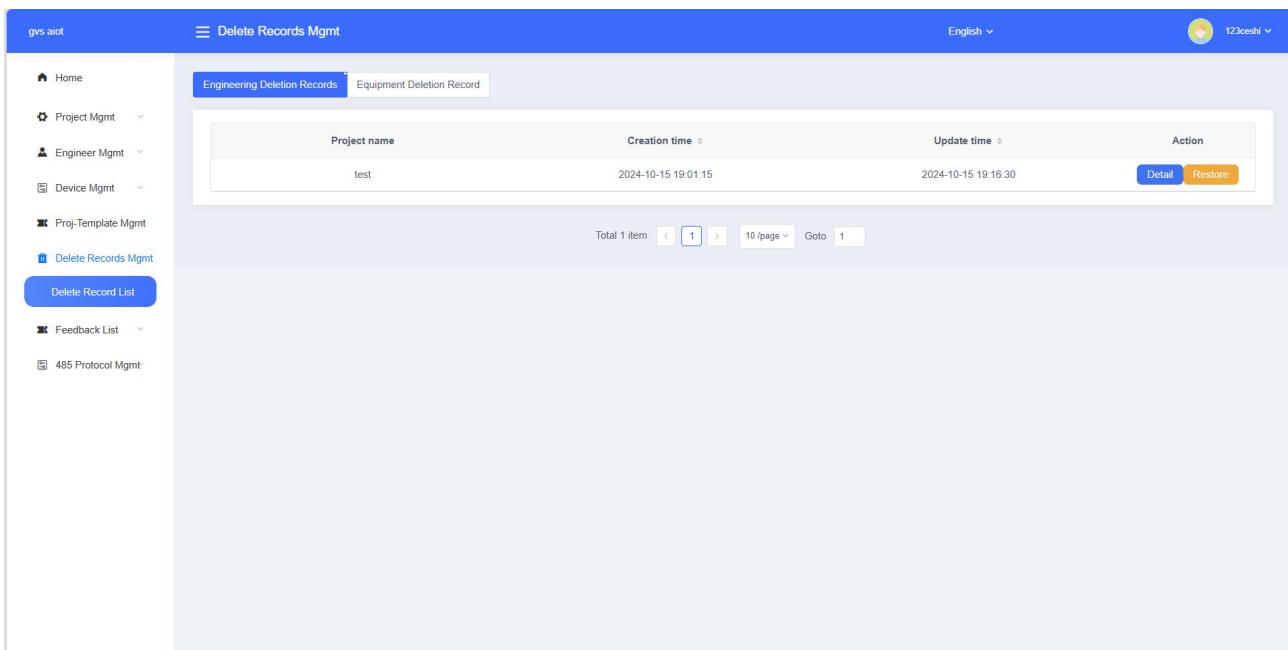

Fig.6.2.7.1 Delete record management

#### (1)Detail

Click "Details" on the interface to view the details of the deleted project/device.

#### (2)Restore

Click "Restore" in the interface, after confirming, you can recover the deleted projects, devices and their configuration files. After voltage recovery, you can see them in the device management and project management interface.

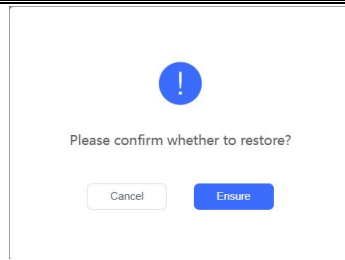

When restoring a project, if there is a conflict with the device bound to the project, you will be prompted with "The currently recovered project has the following devices already applied with other devices, whether to skip these devices". If you select "Confirm", only the configuration information of the building will be restored to the previous status. If the project or building has been deleted, the project and building corresponding to the current device will be restored by default.

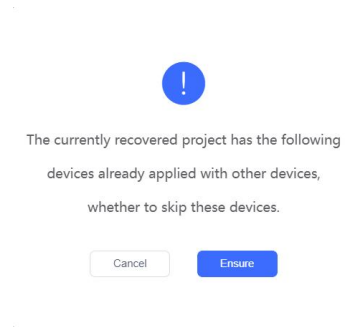

When restoring devices, if there is a device conflict, it will prompt "Association already exists for the device, recovery failed":



### 6.2.8 Feedback list

The feedback interface is shown in Fig.6.2.8.1 below, which is uploaded from "GVS Smart Assistant" APP, and display submitter, feedback content, the submitted time and the current processing status.

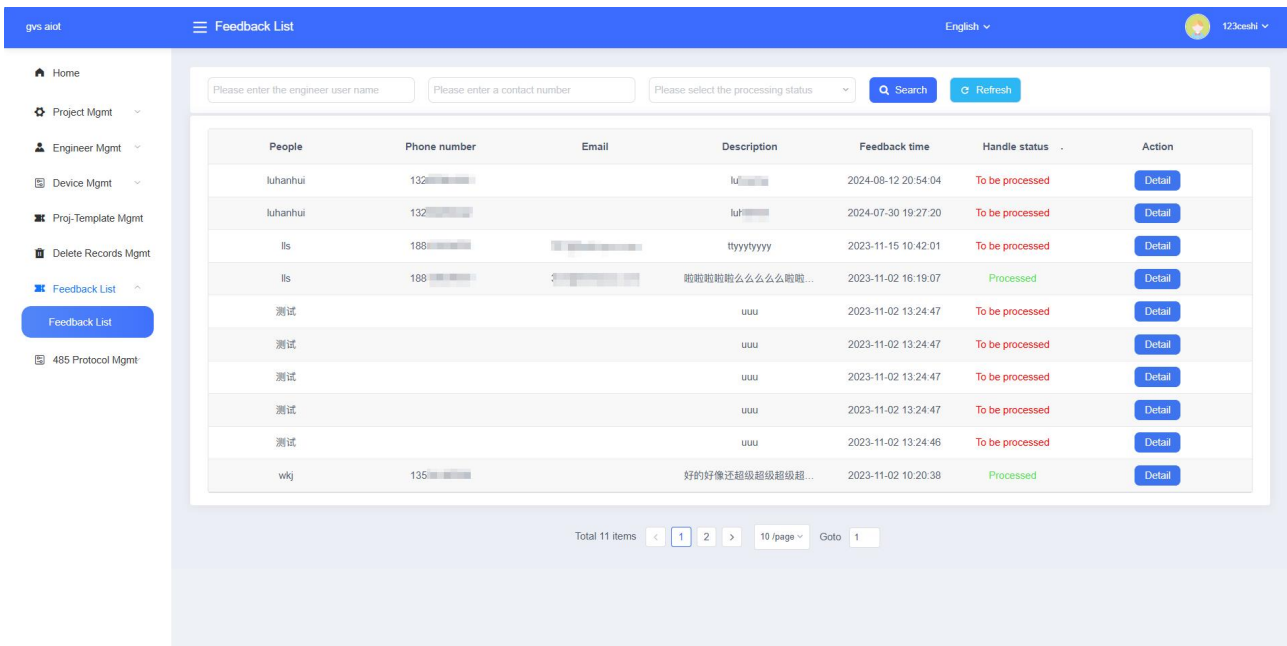

Fig.6.2.8.1 Feedback list

Click "Details" to view the detailed description of the content, as shown in Fig.6.2.8.2 below, and change the feedback status to "Processed"/"Pending".

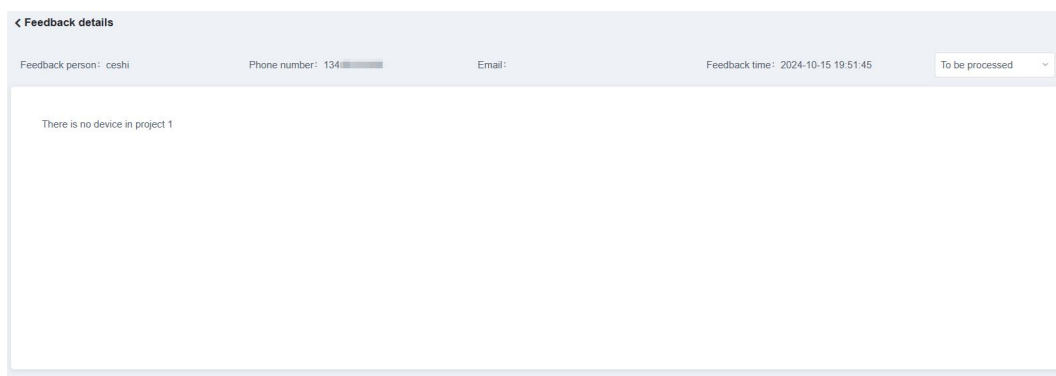

Fig.6.2.8.2 Feedback detail

### 6.2.9 485 Protocol management

The 485 protocol management interface is shown in Fig.6.2.9.1 below, showing all 485/Modbus protocol configuration files under the enterprise, You can create, edit, publish and deactivate these files here.

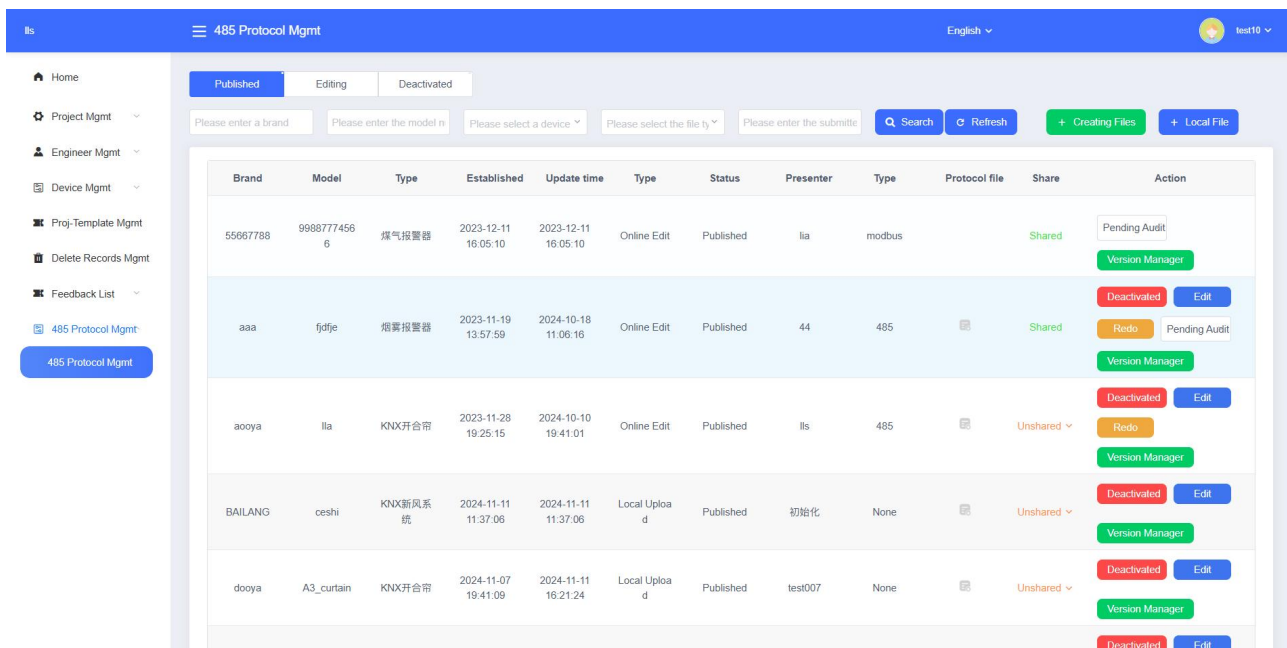

Fig.6.2.9.1 485 Protocol management

#### 6.2.9.1.Cloud file

(1)Create a file

Create a new 485 (or Modbus) protocol file that can be edited online in KNX Engineering Assistant Management Platform (click on it + Creating Files) and enter the necessary information in the window: device type, interface type, protocol type, setup branding and product model.

Add file
✕

\* Type:

\* Interface Type:

\* Protocol:

\* Setup Branding:

\* Model:

Type : choose the device type. If there is no type you need, please contact and feedback to technical support.

Interface type: currently, only the 485 type is supported

Protocol: choose 485 protocol or Modbus protocol.

Setup Branding: enter your brand name.

Model: enter your product model number.

## (2)Edit communication parameter

After the creation is completed, enter the editing list (485 Protocol Mgmt - Editing), select the protocol to edit, and first configure the necessary communication parameters according to the protocol document provided by the manufacturer, as well as upload the document to the platform, as shown in the following figure:

Device Type:

Brand name:

Model:

Communication Rate(bps):

Data Bit(bit):

Stop Bit(bit):

Send interval(ms):

Communication timeout(ms):

Read status interval(s):

Parity check:

Check Type:

Remark:

Protocol file1:

Protocol file2:

Protocol file3:

Device type: display only, not modifiable.

Brand name: displays the brand name and it can be modified.

Model: displays the model name and it can be modified.

Communication Rate (bps): set the communication rate for sending data. You can choose 300, 600, 1200, 2400, 4800, 9600, 19200, 38400, 57600, 115200, or custom input.

Data Bit (bit): set the length for sending data, support to input data bits of 8bit or less.

Stop Bit (bit): set the interval between 2 data telegrams, usually 1 bit.

Send interval (ms): set the time interval for the device to send telegrams to the bus. If it is 0, the function will be inactive. In order to reduce the bus load as much as possible, the maximum time interval should be set according to actual needs to prevent telegrams sticking.

Communication timeout (ms): if no command response or status response is received after sending a telegram, it is judged that the communication has timed out and the control command or read request command will be resent. If it is 0, the function will be inactive.

Read status interval (s): set the time interval for sending device status read request telegram to the bus. Please set it according to actual needs. Too frequent reading may cause too many 485 bus telegrams. If it is 0, the function will be inactive.

Parity check: set the parity check according to the protocol file provided by the manufacturer, N:No Parity, O:Odd Parity, E:Even Parity.

Check Type: set the parity check according to the protocol file provided by the manufacturer, optional: CRC、XOR、SUM、NONE.

Protocol file: the protocol documents (PDF or Word format) provided by the manufacturer need to be uploaded to the platform. At least 1 protocol document should be uploaded, and up to 3 . The size of each document cannot exceed 100M.

Remark: Enter the matters that need to be noted in the protocol application, which cannot exceed 50 words. This information will be displayed in the "GVS Smart Assistant" APP.

(3)Edit protocol

The encoding settings of the Modbus protocol and the 485 protocol are different. Take the device type "KNX Switch" as an example to explain them separately:

1)Edit Modbus protocol

Control Command		End Bit	Name	Length	Data Type	value	Verify starting bit	Verification end bit	Physical model value setting
Status	Switch	8	Slave Address	8	M_DT_BIT		<input type="checkbox"/>	<input type="checkbox"/>	0
Response	Switch	16	Function Code	8	M_DT_BIT	06	<input type="checkbox"/>	<input type="checkbox"/>	0
		32	Register Address	16	M_DT_BYTE_B	1	<input type="checkbox"/>	<input type="checkbox"/>	0
		48	Register Value	16	M_DT_BYTE_B		<input type="checkbox"/>	<input type="checkbox"/>	0
		64	Checksum	16	M_DT_BYTE_B		<input checked="" type="checkbox"/>	48	0

①Add control command

As shown in the figure below, you can expand and see the "Control Command" attribute that can be added +. Select a required function and add it. According to the Modbus protocol standard, the command need to be sent and received simultaneously, and it will automatically add a corresponding "Response" command.

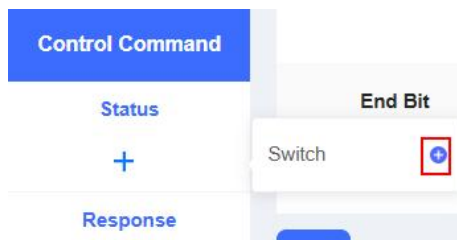

After adding, some of the following information has been preset according to the standard Modbus protocol. If the device uses the standard protocol, no further settings are required. The settings of "Control Command Status" and "Control Command Response" are the same, and are explained below.

End Bit	Name	Length	Data Type	value	Verify starting bit	Verification end bit	Physical model value setting
8	Slave Address	8	M_DT_BIT		<input type="checkbox"/>	<input type="checkbox"/>	ℓ
16	Function Code	8	M_DT_BIT	06	<input type="checkbox"/>	<input type="checkbox"/>	ℓ
32	Register Address	16	M_DT_BYTE_B	1	<input type="checkbox"/>	<input type="checkbox"/>	ℓ
48	Register Value	16	M_DT_BYTE_B		<input type="checkbox"/>	<input type="checkbox"/>	ℓ
64	Checksum	16	M_DT_BYTE_B		<input checked="" type="checkbox"/>	48	ℓ

**End Bit:** display the end bit of the current field, it determined by the setting of "Length".

**Name :** set the name of current field, you can choose: Slave address, Function code, Register address, Register value, Checksum.

Note: all the field names should be set according to the protocol specification, the customized field names do not participate in the verification operation and analysis, do not support the setting of the associated physical model value, and only do the placeholder forwarding.

This system defaults to the standard Modbus protocol format, such as the control telegram is composed of:

Slave address 8bit + Function code 8bit + Register address 16bit + Register value 16bit + Checksum 16bit

**Length :** set the data length of the current field, there is a default length for each field in Modbus protocol, customization is not supported, you can choose: 8bit, 16bit, 24bit.

**Data type :** set the data type of the current field, customization is not supported, you can choose: M\_DT\_BIT (1byte or bit number data type that non-complete byte, such as 4bit), M\_DT\_BYTE\_B (2byte and high bit in the front), M\_DT\_BYTE\_S (2byte and low bit in the front), M\_DT\_STR (string type).

**Value :** set the value corresponding to the current field to be sent to the KNX bus, default input hexadecimal data, the value of each field is set as follows:

Slave Address	The default length is 1byte, which does not need to be set here, and will be written by "GVS Smart Assistant" APP and according to the actual 485 device address.
Function code	The default length is 1byte, the value has been preset according to the standard Modbus protocol, and the default control instruction is 06 (Write Single Holding Register). It can be modified according to the actual protocol definition, but does not support function code 10 (batch control).
Register Address	<p>Length default 2byte type, configured according to the protocol document, you can enter the address value or calculation formula.</p> <p>Take a product as example, address 1 corresponds to the switch function, its register address is 2004, address 2 corresponds to the switch function, its register address is 2008, then here write <math>2000+A*4</math>, where 2000 indicates the offset, A indicates the slave address, and 4 indicates the multiplier relationship.</p>
Register Value	<p>The length of the default 2byte type, enter the current telegram corresponding to the specific value stored in the register, you need to set it in the "Physical model value setting" .</p> <p>The protocols of some manufacturers require data conversion of the transmitted values, and you can enter a formula for the conversion here. For example, an air-conditioning temperature transmission default 3-digit integer, when the temperature is 25.5 °C, you need to send 255 to the air-conditioning gateway, this time to add a formula <math>A*10</math> can be converted to an integer telegram 255, A represents the temperature value.</p>

Checksum	The length is 2byte by default, and there is no need to set the value here. This field is automatically calculated by the system according to the verify mode to get the verify start bit and verify end bit, and complete to the protocol.
----------	---

**Verify starting bit:** configure the value according to the protocol document.

**Verify end bit:** configure the value according to the protocol document.

**Physical model value setting:** click  to set the attributes of the physical model to be associated with the current field and parse the telegram value of this segment.

For example, if the current telegram indicates a switch control function, you need to write the telegram value of switch control in the corresponding register value field. In this case, you need to associate the attribute "switch" with the register value, and then set the start bit and the end bit according to the protocol document, as well as fill in the corresponding on and off values, which are all in decimal. The start and end bits are 0-15 by default, when 2byte, and 0-7 by default when 1byte.

Click  to delete the current attribute, or choose to continue adding other associated attributes.

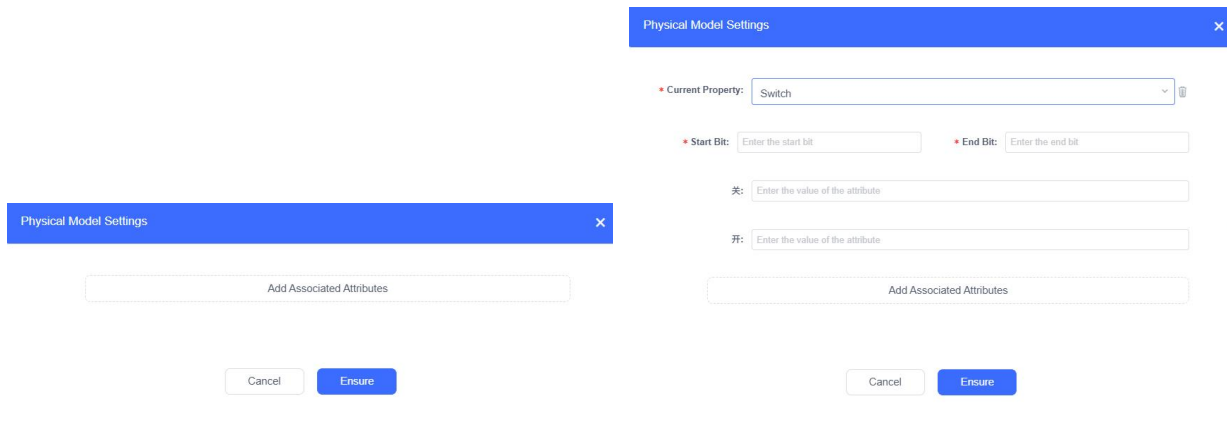

② Add read device command

As shown in the figure below, you can expand and see the "Read Device" attribute that can be added . Select a required function and add it. According to the Modbus protocol standard, it will automatically add a corresponding "Response" command. You can also choose to add a custom to set

up batch status reading.

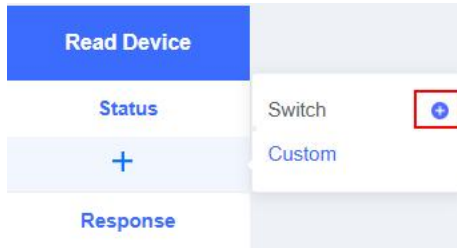

After adding, some of the following information has been preset according to the standard Modbus protocol. If the device uses the standard protocol, no further settings are required. The settings of "Read device Status" and "Read device Status Response" are the same, and are explained below.

End Bit	Name	Length	Data Type	value	Verify starting bit	Verification end bit	Physical model value setting
8	Slave Address	8	M_DT_BIT		<input type="checkbox"/>	<input type="checkbox"/>	∅
16	Function Code	8	M_DT_BIT	03	<input type="checkbox"/>	<input type="checkbox"/>	∅
32	Register Address	16	M_DT_BYTE_B	11	<input type="checkbox"/>	<input type="checkbox"/>	∅
48	Number of register	16	M_DT_BYTE_B	2	<input type="checkbox"/>	<input type="checkbox"/>	∅
64	Checksum	16	M_DT_BYTE_B		<input checked="" type="checkbox"/>	48	∅

**End Bit:** display the end bit of the current field, it determined by the setting of "Length".

**Name:** set the name of current field.

When it is "Status", you can choose: Slave address, Function code, Register address, Number of register, Checksum.

When it is "Response", you can choose: Slave address, Function code, Register address, Number of register, Checksum, Register value, Register-1, Register-2, Register-3...The number of register-n depends on the setting of the number of registers.

Note: all the field names should be set according to the protocol specification, the customized field names do not participate in the verification operation and analysis, do not support the setting of the associated physical model value, and only do the placeholder forwarding.

This system defaults to the standard Modbus protocol format, such as the status telegram is composed of:

Slave address 8bit + Function code 8bit + Register address 16bit + Register value -116bit...+

Register value -n16bit + Checksum 16bit



Note: the maximum length of each telegram cannot exceed 50 bytes.

**Length**: set the data length of the current field, there is a default length for each field in Modbus protocol, customization is not supported, you can choose: 8bit, 16bit, 24bit.

**Data type**: set the data type of the current field, customization is not supported, you can choose: M\_DT\_BIT (1byte or bit number data type that non-complete byte, such as 4bit), M\_DT\_BYTE\_B (2byte and high bit in the front), M\_DT\_BYTE\_S (2byte and low bit in the front), M\_DT\_STR (string type).

**Value**: set the value corresponding to the current field to be sent to the KNX bus, default input hexadecimal data, the value of each field is set as follows:

Slave Address	<p>The default length is 1byte, which does not need to be set here, and will be written by "GVS Smart Assistant" APP and according to the actual 485 device address.</p> <p>Note: the address of some protocols is 1-1 or 2-1, you need to enter the corresponding address according to the actual number; the default address configuration on "GVS Smart Assistant" is master address + slave address.</p>
Function code	<p>The default length is 1 byte type. This value has been preset according to the standard Modbus protocol. The default status read instruction is 03 (Read holding register) or 04 (Read input register). It can be modified according to the actual protocol definition.</p>

<p>Register Address</p>	<p>Length default 2byte type, configured according to the protocol document, you can enter the address value or calculation formula.</p> <p>Take a product as example, address 1 corresponds to the switch function, its register address is 2004, address 2 corresponds to the switch function, its register address is 2008, then here write 2000+A*4, where 2000 indicates the offset, A indicates the slave address, and 4 indicates the multiplier relationship.</p>
<p>Number of register</p>	<p>The default length is 2byte type. In "Read Device Status", set the number of registers to read when sending a read request. If you add  instructions directly from the default attributes, such as "Switch", only one register is required, and the value is set to 1.</p>
<p>Register Value/ Register-n</p>	<p>The default length is 2byte type. In "Read Device Status Response", enter the specific value stored in the register corresponding to the current telegram, you need to set it in the "Physical model value setting" .</p> <p>The number of Registers-n depends on the setting of the number of registers.</p> <p>The protocols of some manufacturers require data conversion of the transmitted values, and you can enter a formula for the conversion here. For example, the feedback temperature from air-conditioning is default to 3-digit integer, when the temperature is 25.5 °C, it will response 255 to the bus, this time to add a formula A/10 can be converted to a float telegram, A represents the temperature value.</p>
<p>Checksum</p>	<p>The length is 2byte by default, and there is no need to set the value here. This field is automatically calculated by the system according to the verify mode to get the verify start bit and verify end bit, and complete to the protocol.</p>

**Verify starting bit:** configure the value according to the protocol document.

**Verify end bit:** configure the value according to the protocol document.

**Physical model value setting:** click  to set the attributes of the physical model to be associated with the current field and parse the telegram value of this segment.

For example, if the current telegram indicates a switch status function, you need to write the telegram value of switch status in the corresponding register value field. In this case, you need to associate the attribute "switch" with the register value, and then set the start bit and the end bit according to the protocol document, as well as fill in the corresponding on and off values, which are all in decimal. The start and end bits are 0-15 by default, when 2byte, and 0-7 by default when 1byte.

Click  to delete the current attribute, or choose to continue adding other associated attributes.

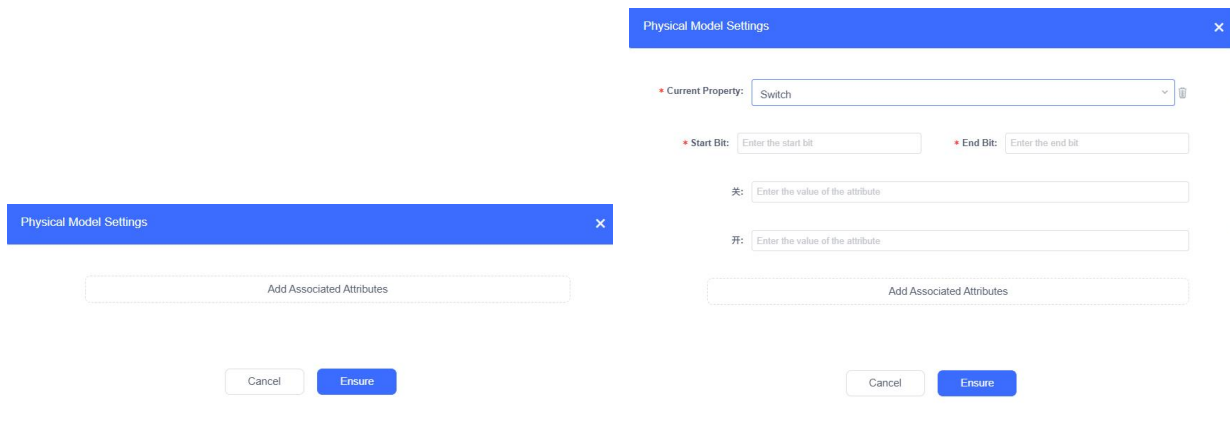

### ③ Move/Add/Delete/Copy

For commands, you can perform the operations of deleting/copy.

End Bit	Name	Length	Data Type	value	Verify starting bit	Verification end bit	Physical model value setting
8	Slave Address	8	M_DT_BIT		<input type="checkbox"/>	<input type="checkbox"/>	ℓ
16	Function Code	8	M_DT_BIT	06	<input type="checkbox"/>	<input type="checkbox"/>	ℓ
32	Register Address	16	M_DT_BYTE_B	1	<input type="checkbox"/>	<input type="checkbox"/>	ℓ
48	Register Value	16	M_DT_BYTE_B		<input type="checkbox"/>	<input type="checkbox"/>	ℓ
64	Checksum	16	M_DT_BYTE_B		<input checked="" type="checkbox"/>	48	ℓ

For the fields in the instruction, you can perform the operations of adding, moving up, moving down,

copying and deleting, adjusting them according to the protocol document.

End Bit	Name	Length	Data Type	value	Verify starting bit	Verification end bit	Physical model value setting
8	Slave Address	8	M_DT_BIT		<input type="checkbox"/>	<input type="checkbox"/>	ℓ
16	Function Code	8	M_DT_BIT	06	<input type="checkbox"/>	<input type="checkbox"/>	ℓ
32	Register Address	16	M_DT_BYTE_B	1	<input type="checkbox"/>	<input type="checkbox"/>	ℓ
48	Register Value	16	M_DT_BYTE_B		<input type="checkbox"/>	<input type="checkbox"/>	ℓ
64	Checksum	16	M_DT_BYTE_B		<input checked="" type="checkbox"/>	48	ℓ

2)Edit 485 protocol

As shown in the figure below, you can see the commands that can be added: Send control command, Receive status report, and status. There is no template preset for adding commands in 485 protocol. You can add the required commands according to the protocol requirements. The methods of adding the three commands are the same. The following takes "Control command" as an example.

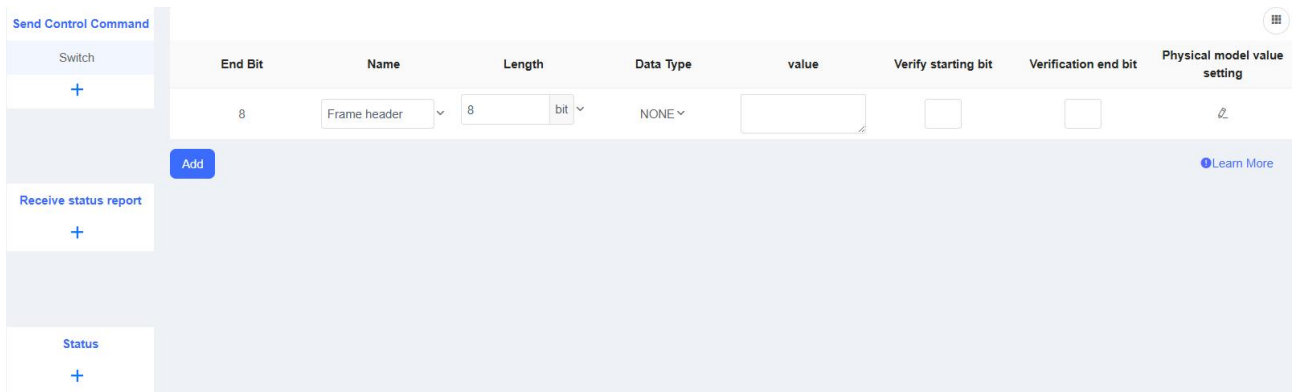

①Add command

As shown in the figure below, you can expand and see the "Control Command" attribute that can be added.

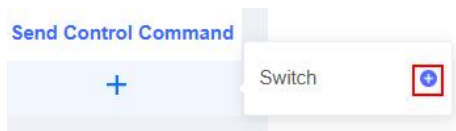

After adding, for the fields in the instruction, you need to add [Add](#) them by yourself according to the protocol document. The settings are explained below.

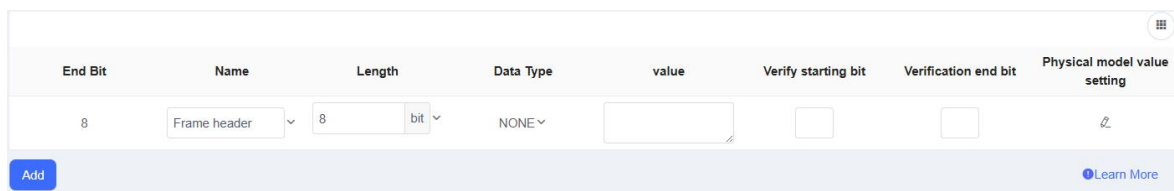

**End Bit:** display the end bit of the current field, it determined by the setting of "Length".

**Name:** set the name of current field, you can choose: Frame header, Device Address, Function Code, Function Subcode, Data length, Data content, Checksum, End of frame or custom input.

Note: all the field names should be set according to the protocol specification, the customized field names do not participate in the verification operation and analysis, do not support the setting of the associated physical model value, and only do the placeholder forwarding.

**Length** : set the data length of the current field, there is a default length for each field in Modbus protocol, customization is not supported, you can choose: 8bit, 16bit, 24bit. Or customize the input length, range: 0~24bit.

**Data type** : set the data type of the current field, customization is not supported, you can choose: NONE, BIT (bit number data type that non-complete byte, such as 4bit), 1BYTE, 2BYTE\_B (high bit in the front), 2BYTE\_S (low bit in the front), 3BYTE\_B (high bit in the front), 3BYTE\_S (low bit in the front), STR (string type).

**Value** : set the value corresponding to the current field to be sent to the KNX bus, default input hexadecimal data, the value of each field is set as follows:

Frame header	There is no need to set the value here. This field is automatically calculated by the system according to the verify mode, and complete to the protocol.
Device Address	The length is generally 2 bytes, for example, 1 byte represents the air conditioning gateway address, and 1 byte represents the sub-device address.
Function Code	Configured according to the protocol document, the field that indicates the functional attribute corresponding to the current telegram.
Function Subcode	Configured according to the protocol document, the field that indicates the functional sub attribute corresponding to the current telegram.
Data length	There is no need to set the value here.

Data content	<p>Enter the current telegram corresponding to the specific value stored in the register, you need to set it in the "Physical model value setting" .</p> <p>The protocols of some manufacturers require data conversion of the transmitted values, and you can enter a formula for the conversion here. For example, an air-conditioning temperature transmission default 3-digit integer, when the temperature is 25.5 °C, you need to send 255 to the air-conditioning gateway, this time to add a formula <math>A*10</math> can be converted to an integer telegram 255, A represents the temperature value.</p>
Checksum	<p>The length is 2byte by default, and there is no need to set the value here. This field is automatically calculated by the system according to the verify mode to get the verify start bit and verify end bit, and complete to the protocol.</p>
End of frame	<p>It is empty by default.</p>

**Verify starting bit:** configure the value according to the protocol document.

**Verify end bit:** configure the value according to the protocol document.

**Physical model value setting:** click  to set the attributes of the physical model to be associated with the current field and parse the telegram value of this segment.

For example, if the current telegram indicates a switch control function, you need to write the telegram value of switch control in the corresponding register value field. In this case, you need to associate the attribute "switch" with the register value, and then set the start bit and the end bit according to the protocol document, as well as fill in the corresponding on and off values, which are all in decimal.

Click  to delete the current attribute, or choose to continue adding other associated attributes.

Physical Model Settings ✕

Add Associated Attributes

Cancel
Ensure

Physical Model Settings ✕

Current Property: Switch

Start Bit: Enter the start bit      End Bit: Enter the end bit

类: Enter the value of the attribute

开: Enter the value of the attribute

Add Associated Attributes

Cancel
Ensure

### ③ Move/Add/Delete/Copy

For commands, you can perform the operations of deleting/copy.

	End Bit	Name	Length	Data Type	value	Verify starting bit	Verification end bit	Physical model value setting
Send Control Command	8	Frame header	8 bit	NONE	<input style="width: 50px;" type="text"/>	<input type="checkbox"/>	<input type="checkbox"/>	ℓ
+	16	Device Address	8 bit	NONE	<input style="width: 50px;" type="text"/>	<input type="checkbox"/>	<input type="checkbox"/>	ℓ
Receive status	24	Function Code	8 bit	NONE	<input style="width: 50px;" type="text"/>	<input type="checkbox"/>	<input type="checkbox"/>	ℓ
Switch	32	Function Subcode	8 bit	NONE	<input style="width: 50px;" type="text"/>	<input type="checkbox"/>	<input type="checkbox"/>	ℓ
+	40	Data length	8 bit	NONE	<input style="width: 50px;" type="text"/>	<input type="checkbox"/>	<input type="checkbox"/>	ℓ
Status	48	Data content	8 bit	NONE	<input style="width: 50px;" type="text"/>	<input type="checkbox"/>	<input type="checkbox"/>	ℓ
Switch	56	Checksum	8 bit	NONE	<input style="width: 50px;" type="text"/>	<input type="checkbox"/>	<input type="checkbox"/>	ℓ
+	64	End of frame	8 bit	NONE	<input style="width: 50px;" type="text"/>	<input type="checkbox"/>	<input type="checkbox"/>	ℓ

Add
Learn More

For the fields in the instruction, you can perform the operations of adding, moving up, moving down, copying and deleting, adjusting them according to the protocol document.

End Bit	Name	Length	Data Type	value	Verify starting bit	Verification end bit	Physical model value setting
8	Frame header	8 bit	NONE		<input type="checkbox"/>	<input type="checkbox"/>	∅
16	Device Address	8 bit	NONE		<input type="checkbox"/>	<input type="checkbox"/>	∅
24	Function Code	8 bit	NONE		<input type="checkbox"/>	<input type="checkbox"/>	∅
32	Function Subcode	8 bit	NONE		<input type="checkbox"/>	<input type="checkbox"/>	∅
40	Data length	8 bit	NONE		<input type="checkbox"/>	<input type="checkbox"/>	∅
48		8 bit	NONE		<input type="checkbox"/>	<input type="checkbox"/>	∅
56		8 bit	NONE		<input type="checkbox"/>	<input type="checkbox"/>	∅
64		8 bit	NONE		<input type="checkbox"/>	<input type="checkbox"/>	∅

[Learn More](#)

### (6)Apply file

After completing the protocol settings, save and return to the edit list to apply the protocol (485 Protocol Mgmt - Editing - click **Apply** ). After applying, the protocol will be displayed in the published list (485 Protocol Mgmt - Published), and then it can be used and delivered to the device in the "GVS Smart Assistant" APP.



Are you sure to apply the protocol, after which the protocol will be able to be called down to the device?

### (7)Delete file

Return to the edit list and delete the protocol (485 Protocol Mgmt - Editing - click **Delete** ).

Note: after deletion, editing can be restored in the deactivated list.

### 6.2.9.2. Local file

Upload a configuration file in the KNX Engineering Assistant Management Platform (click

[+ Local File](#)), enter the information and upload the necessary files.

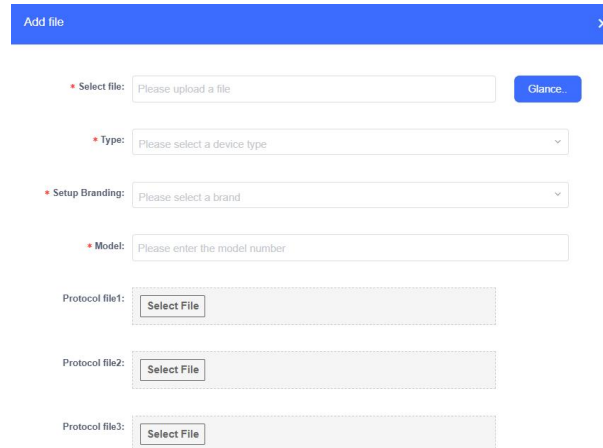

The screenshot shows a modal window titled "Add file" with a close button (X) in the top right corner. The form contains the following fields:

- Select file:** A text input field with the placeholder "Please upload a file" and a blue "Glance..." button to its right.
- Type:** A dropdown menu with the placeholder "Please select a device type".
- Setup Branding:** A dropdown menu with the placeholder "Please select a brand".
- Model:** A text input field with the placeholder "Please enter the model number".
- Protocol file 1:** A text input field with a "Select File" button.
- Protocol file 2:** A text input field with a "Select File" button.
- Protocol file 3:** A text input field with a "Select File" button.

Select file: upload local files, only bin, ini format is supported.

Type : choose the device type. If there is no type you need, please contact and feedback to technical support.

Setup Branding: enter your brand name.

Model: enter your product model number.

Protocol file: the protocol documents (PDF or Word format) provided by the manufacturer need to be uploaded to the platform. At least 1 protocol document should be uploaded, and up to 3 . The size of each document cannot exceed 100M.

### 6.2.9.3. Published file management

For published protocol files, you can perform the following operations in the list (485 Protocol Mgmt - Published):

Brand	Model	Type	Established	Update time	Type	Status	Presenter	Type	Protocol file	Share	Action
GVS	Modbus-SW	KNX开关	2024-12-31 13:58:05	2024-12-31 14:39:46	Online Edit	Published	test	modbus		Unshared ▾	<span>Deactivated</span> <span>Edit</span> <span>Redo</span> <span>Version Manager</span>

(1)Share



Click in the list and confirm. The configuration file will be shared with GVS. After the administrator passes the audit, the file will be shared to the public platform, and all GVS users can use this agreement.

Share can not be withdrawn, if you need to cancel the release to the public platform, then change the audit status to "Pending Audit".

The unshared files are only available to members of the company to which they belong.



Confirm to share this configuration file to Sight & Sound Intelligence, after we review it, it will be released to the public platform, all Sight & Sound users will be able to use this protocol, thank you for sharing!

Brand	Model	Type	Established	Update time	Type	Status	Presenter	Type	Protocol file	Share	Action
GVS	Modbus-SW	KNX开关	2024-12-31 13:58:05	2024-12-31 14:39:46	Online Edit	Published	test	modbus		Shared	<span>Deactivated</span> <span>Edit</span> <span>Redo</span> <span>Pending Audit</span> <span>Version Manager</span> <span>Audit</span> <span>Pending Audit</span>

## (2)Edit

Click  in the list to edit the information of the published file: replace the configuration file, change the brand name, product model, and replace or supplement the agreement document.

The operation of replacing the configuration file is only valid for the locally uploaded files, and the online configuration files cannot be replaced.

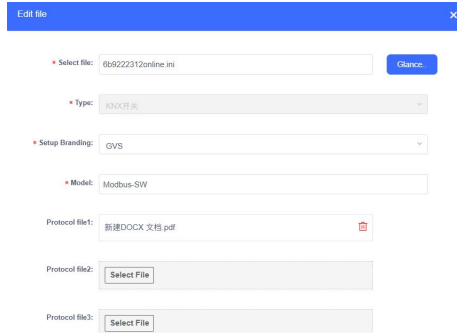

## (2)Restore edit

Click  in the list, the file will be restored to edit, and after confirmation, the file will be returned to the edit list (485 Protocol Mgmt - Editing ).

This operation is only supported for files configured online.

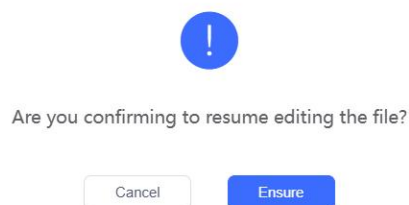

When the protocol is changed and saved, the difference between the current protocol and the previous protocol will be checked by default. If there is a difference, a version will be iterated when saving.

If the number of version reaches 14, it will be prompted when saving: The protocol version is no

more than 16, and the current one is the 14th. Please process the historical data in time, otherwise the historical versions will be overwritten in order.

### (3)Version management

Click **Version Manager** in the list to view the version information of the file. Up to 16 versions can be saved, and old versions can be deleted in this interface. The current version is the latest version and cannot be deleted.

Brand	Model	Type	Established	Type	Presenter	Type	Protocol file	Version	Action
GVS	Modbus-SW	KNX开关	2024-12-31 14:45:22	Online Edit	test	modbus		V1.1(Current version)	<b>Delete</b>
GVS	Modbus-SW	KNX开关	2024-12-31 13:58:05	Online Edit	test	modbus		V1.0	<b>Delete</b>

### (4)Deactivated

Click **Deactivated** in the list, the protocol will be deactivated, and it will not be available after deactivation.

After deactivation, the existing configuration on the "GVS Smart Assistant" will not be removed.

Please replace the 485 protocol that can be used normally in the APP in time.



Do you confirm deactivation of the protocol, after deactivation you will not be able to call the protocol! Deactivation can be viewed in Deactivated.

### 6.2.9.4. Deactivated file management

For deactivated protocol files, you can do the following:

Brand	Model	Type	Established	Update time	Type	Status	Presenter	Type	Protocol file	Action
GVS	haixin11	KNX开关	2023-11-24 1 0:40:53	2023-11-29 1 6:52:31	Local Upload	Deactivated	lls	None		Restore APPL Delete
GVS	Hisence_m	KNX开关	2023-11-23 1 7:31:01	2023-11-24 1 0:09:23	Local Upload	Deactivated	lls	modbus		Restore APPL Delete
GVS	Modbus-SW	KNX开关	2024-12-10 1 7:31:17	2024-12-10 1 7:44:58	Online Edit	Deactivated	test	modbus		Redo Delete

#### (1) Restore apply

Click **Restore APPL** in the list, the file will be restored to apply, after confirmation, the file will be returned to the publish list (485 Protocol Mgmt - Published).

Click **Redo** in the list, the file will be restored to editing, after confirmation, the file will be returned to the editing list (485 Protocol Mgmt - Editing). This operation is only supported for files configured online.

#### (2) Delete

Click **Delete** in the list and the file will be completely deleted and cannot be recovered.