

## Outdoor Station

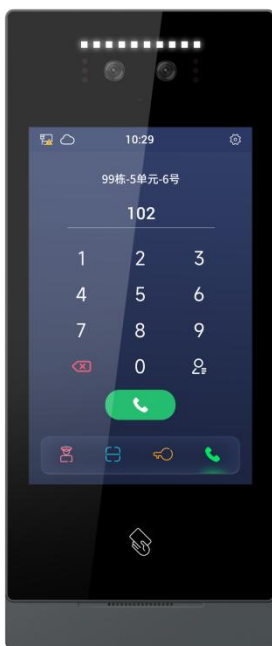

**H Series - Outdoor Station With Face Recognition User Manual\_V1.0**

**Model: H-OS18S、H-OS18S-P48**

# Attentions

- 1、 Please keep devices away from strong magnetic field , high temperature , wet environment ;



- 2、 Please do not fall the devices to the ground or make them get hard impact ;



- 3、 Please do not use wet cloth or volatile reagent to wipe the devices ;



- 4、 Please do not disassemble the devices.

# Content

<b>Chapter 1 Overview</b> .....	<b>1</b>
1.1 Functions and Characteristics .....	1
1.2 Specifications .....	2
<b>Chapter 2 Appearance and Interface</b> .....	<b>3</b>
2.1 Front View .....	3
2.2 Product Dimension .....	4
2.3 Rear View .....	5
<b>Chapter 3 Installation</b> .....	<b>7</b>
3.1 Installation Illustration .....	7
3.2 Installation Height .....	9
3.3 Wiring Diagrams .....	9
<b>Chapter 4 Operation Instructions</b> .....	<b>12</b>
4.1 Calling Management Center .....	12
4.2 Unlock by Face Recognition & Code Scanning .....	13
4.3 Unlock by PIN .....	14
4.4 Calling .....	15
<b>Chapter 5 Setting</b> .....	<b>17</b>
5.1 RingTone Setting .....	18
5.2 Time Setting .....	19
5.3 Language Setting .....	19
5.4 Unlock Setting .....	20
5.5 Call setting .....	22
5.6 Contact List Management .....	23
5.7 Face management .....	25
5.8 Access card management .....	26
5.9 Data synchronization (no server mode) .....	27
5.10 Data backup (No Server Mode) .....	27
5.11 Lift Control .....	28
5.12 Alarm Setting .....	29
5.13 Engineering Setting .....	30

5.14 About..... 37

**Chapter 6 Appendix.....40**

# Chapter 1 Overview

The Outdoor station is one of the main parts in digital video door phone system. It is connected by standard CAT 5 cable and can be used for intercom and unlocking functions with Indoor Monitor or Guard Unit.

## 1.1 Functions and Characteristics

- 8" IPS display
- Auto fill light with high luminance LED
- Support multiple face detection, face tracking, live detection, mask recognition and other functions with binocular wide dynamic&near infrared camera and Megvii face recognition algorithm. The face recognition rate is less than 0.5s and false recognition rate is 0.1% in a standard environment with 10,000 person.
- Unlock with nine modes: password, IC card, pushbutton, monitoring/call, face recognition, QR code, APP, face&public password, face&access card
- Compatible with cloud server management, LAN server management, no server management and various server management modes
- Support alarm input, alarm output and 12V output with 800mA MAX
- Support human movement detection
- Support lift linkage
- Support Wiegand setting
- Support door status detection and timeout alarm, disconnection alarm and tamper alarm
- Support OTA online upgrade

## 1.2 Specifications

System: Linux  
RAM: 512MB  
Face Storage: 20,000

CPU: 2 x Cortex-A7 1.2GHz 32K  
ROM: 4GB

### Working Parameters

Working Voltage: 18~30V  
(DC24V as standard)  
Working Current: <400mA (DC24V)  
Storage Temperature: -30°C ~ +70°C

Static Current: <150mA (DC24V)  
Working Temperature: -20°C ~ +70°C  
Humidity: ≤ 95%, no condensation

### Camera

Type: CMOS  
FOV Field of View:  
H: 61 degrees, V: 35 degrees  
LED: IR 850nm + white light

Pixels: 2 Mega Pixels  
Focal Distance: 4.3mm  
Minimum Illuminance: ≤0.15 Lux/F2.0

### Display

Type: LCD  
Resolution: 800\*1280

Size: 8"

### Product Dimension

W/H/D: 130 x 308 x 26.50 mm

# Chapter 2 Appearance and Interface

## 2.1 Front View

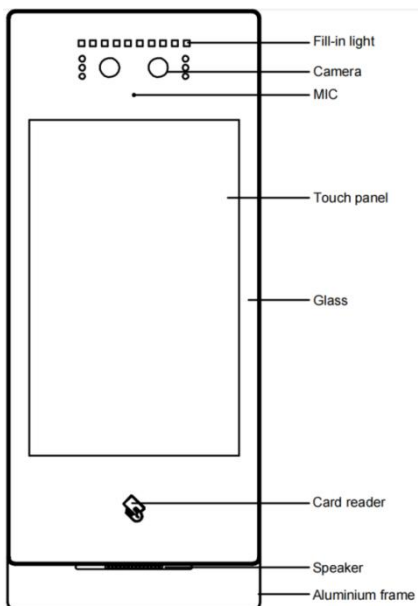

## 2.2 Product Dimension

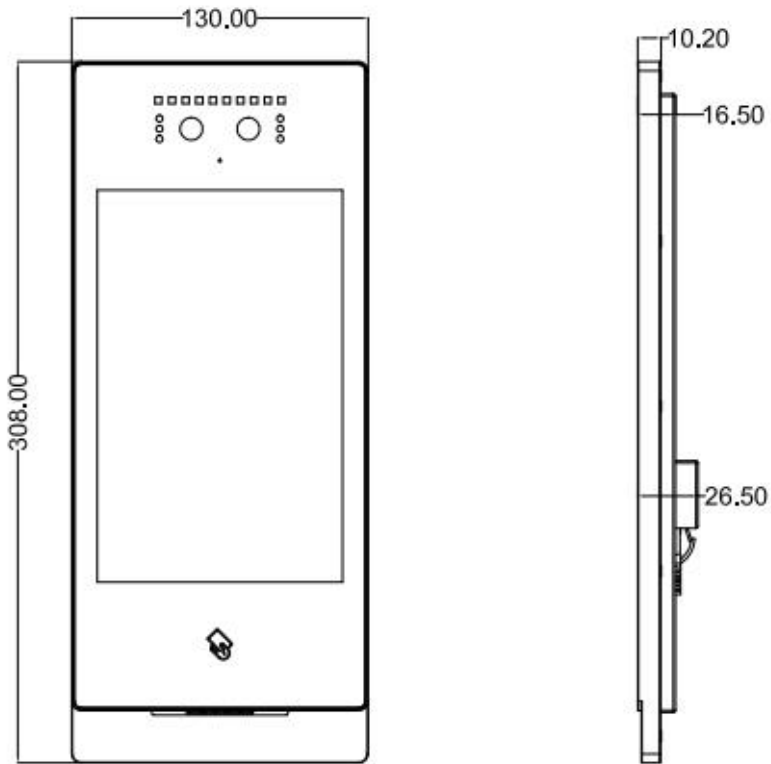

## 2.3 Rear View

- H-OS18

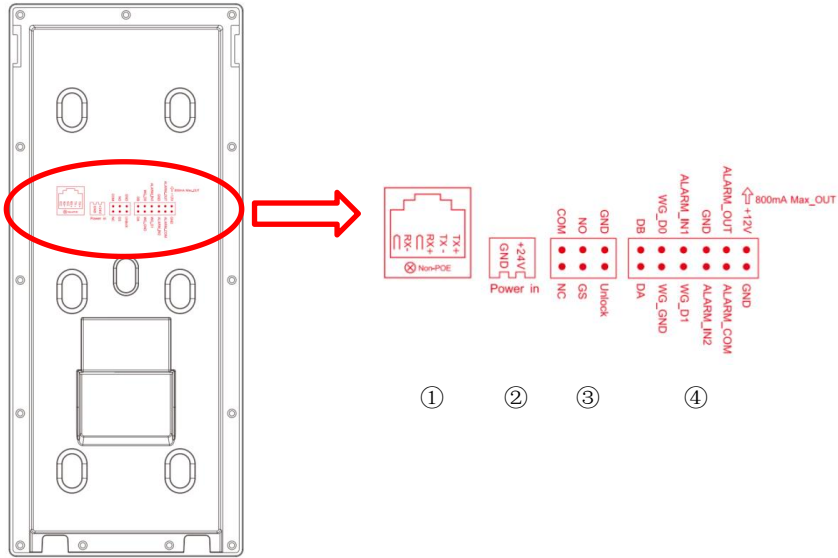

①	RJ45 network interface
②	Interface for power supply: DC 24V (interface for independent power supply, working voltage DC 18~30V)
③	COM, NO, NC: Common pin, normally-open pin, and normally-closed pin. GS: Door status detection. UNLOCK, GND: Unlock Push Button interface
④	WG-GND, WG-D0, WG-D1: Wiegand interface DA, DB: RS485 interface ALARM_IN1: Alarm input 1 ALARM_IN2: Alarm input 2 GND: GND ALARM_OUT: Lock2 interface normally-open pin ALARM_COM: Lock2 interface common pin GND: GND +12V_OUT: +12V power output

● H-OS18-P48

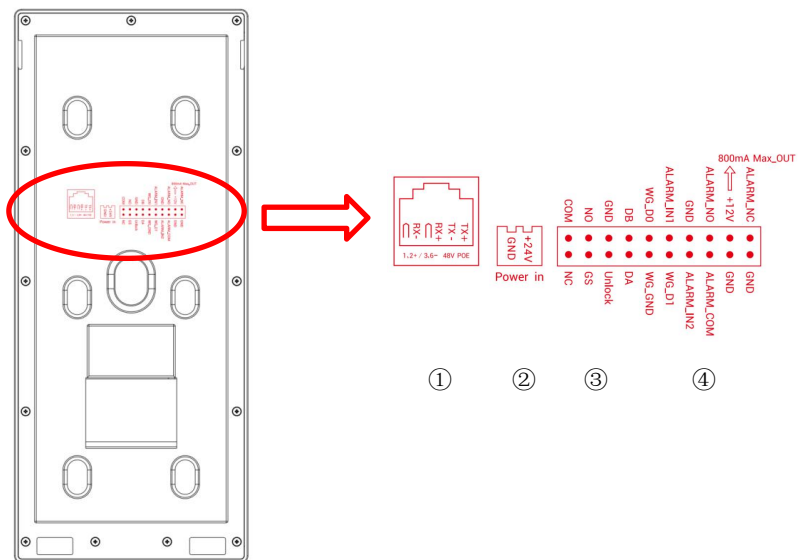

①	RJ45 network interface(Standard 48V PoE power supply)
②	Interface for power supply: DC 24V (interface for independent power supply, working voltage DC 18~30V)
③	COM, NO, NC: Common pin, normally-open pin, and normally-closed pin. GS: Door status detection. UNLOCK, GND: Unlock Push Button interface
④	WG-GND, WG-D0, WG-D1: Wiegand interface DA, DB: RS485 interface ALARM_IN1: Alarm input 1 ALARM_IN2: Alarm input 2 GND: GND ALARM_OUT: Lock2 interface normally-open pin ALARM_COM: Lock2 interface common pin GND: GND +12V_OUT: +12V power output

# Chapter 3 Installation

## 3.1 Installation Illustration

### (1) Method 1: Embedded in Wall

Step 1: Put embedded box into preformed groove and get cable out through the opening (as shown in Picture 1). Embedded box dimension(W/H/D) is 114 x 292.5 x 38 (mm).

Step 2: After connecting cable to outdoor station, match slot on rear cover of the outdoor station to align with snap on embedded box and snap on the outdoor station (as shown in Picture 2).

Step 3: Fix screws at the bottom of aluminium panel (as is shown in Picture 3).

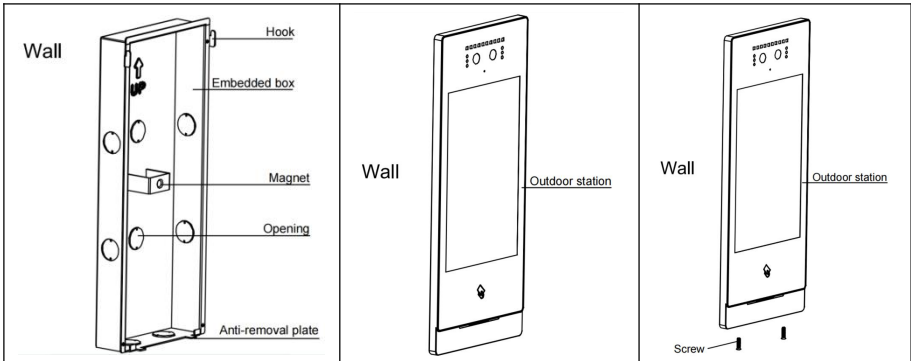

### (2) Method 2: Wall-mounted

Step 1: Locate wall bracket according to the opening for cable, match 6 mounting holes on wall bracket, drill corresponding holes in the wall, insert expansion plugs and finally tighten the bracket with screws(as shown in Picture 1).

Step 2: After connecting cable to outdoor station, match slot on rear cover of the outdoor station to align with snap on embedded box and snap on the outdoor station (as shown in Picture 2).

Step 3: Fix screws at the bottom of aluminium panel (as is shown in Picture 3).

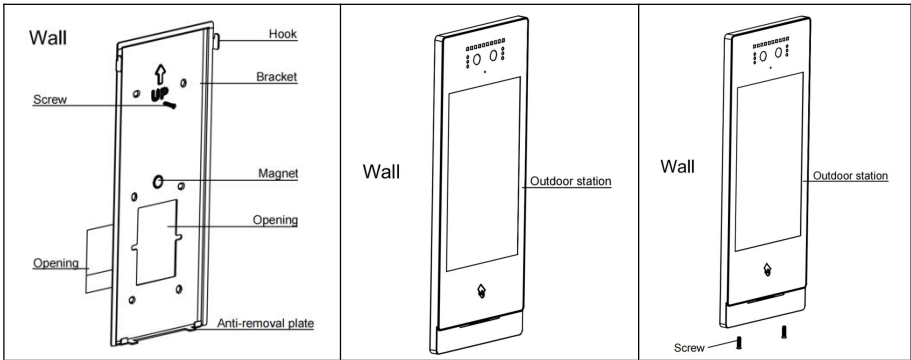

### (3) Mode 3: Column

It's required to open a  $\Phi 33\text{mm}$  hole in the device that customer provided, get the cable between customer-supplied device and the host out through opening, and then get cable out through the column. Assemble the column and gum a waterproof sticker to the fixed part of the column and column bracket (as shown in Picture 1).

Step 2: Fix column bracket to the column with screws and attach waterproof foam to the end of column bracket (as shown in Picture 2).

Step 3: The wall bracket shall be screwed to column bracket (as shown in Picture 3).

Step 4: Fix screws at the bottom of aluminium panel (as is shown in Picture 4).

Step 5: Pass the column through the hole opened in customer-supplied device and fix the column to it with column fixing nut.

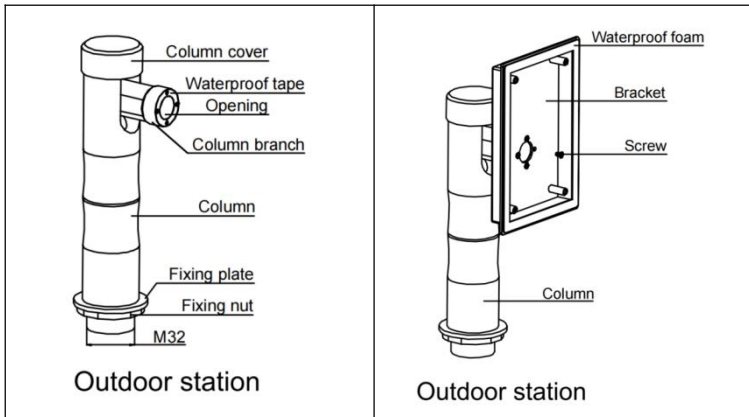

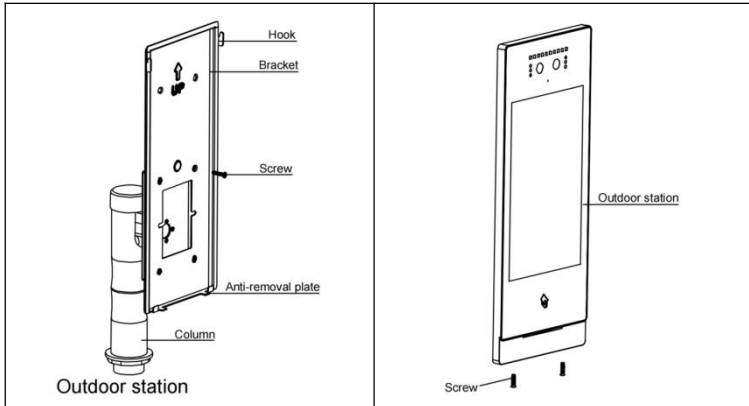

### 3.2 Installation Height

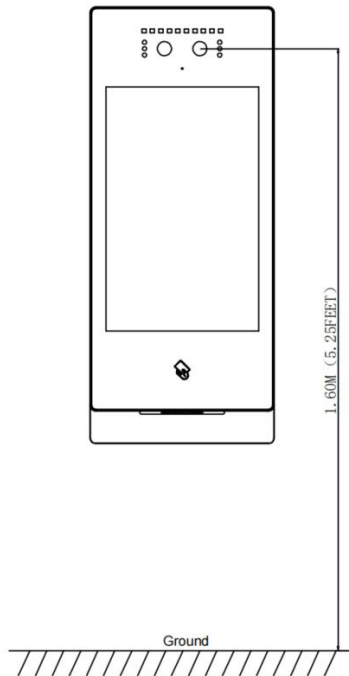

Recommended Installation Height: 1.6 meters

### 3.3 Wiring Diagrams

#### (1) Wiring for Signal Unlock Mode

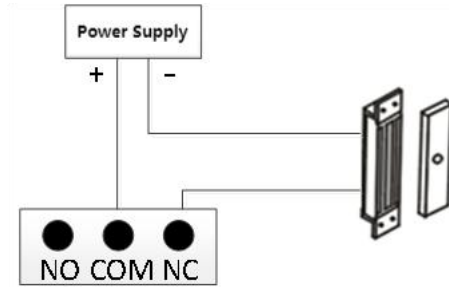

Wiring for normally closed type lock(Magnetic Lock)

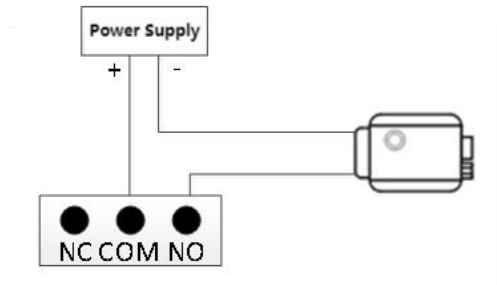

Wiring for normally open type lock(Electronic lock)

**Note:** If device is used for power supply under signal unlock mode, the device can only be powered by extra power supply. At the mean time, lock input current shall be less than 800mA, otherwise the equipment may be damaged.

## (2) Wiring for Exit Button Unlock Mode

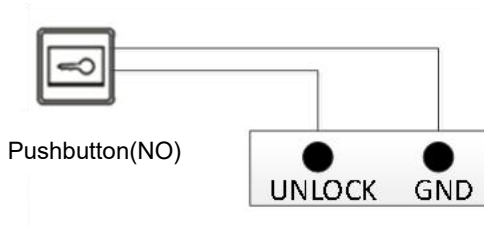

**Note:** This wiring is not polarised.

## (3) Wiring for Door Status Alarm

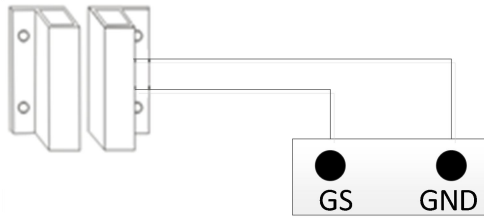

Normally closed type

**Note:** The door status alarm function can be switched off in two ways.

- ① Grounding GS port of the host.
- ② Enter "Door Status Alarm" and turn off the door status alarm switch.

# Chapter 4 Operation Instructions

(1) Initialisation: When the device is first powered up, user needs to select the language (Simplified Chinese, Traditional Chinese, English) and working mode (Cloud Server Mode, Local Server Mode, No Server Mode).

**Notes:**

- ① To change operation mode, please click on Restore Factory Settings within 60s of re-powering to re-select it.
  - ② Enter local server address (computer IP + port 8103, e.g. 10.0.0.1:8103) when Local Server Mode is chosen. If there is a port conflict at site, please contact technical support to work with the developer to change port number, and modified port number will prevail.
- (2) All functions in main screen can be turned on or off in Setting.

## 4.1 Calling Management Center



*Interface of Calling Management Center*

By clicking  on main screen, user can call the management center and the device will ring back. If there is no answer from the management center within 30s, call will be automatically terminated.

## 4.2 Unlock by Face Recognition & Code Scanning

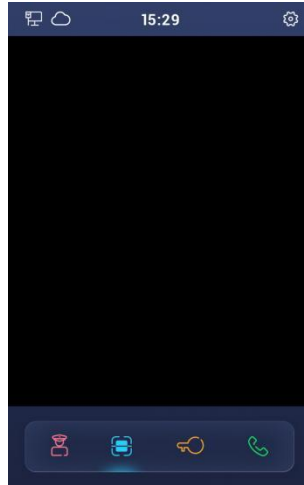

*Interface of Face Recognition & Code Scanning*

After clicking  on main screen, Outdoor Station scans face or unlocking QR code and after identifying it as correct, door unlocks.

**Note:**

- ① When registered users approach the Outdoor Station with their face facing device camera, it automatically enters face recognition function to unlock the door.
- ② The unlocking QR code is generated by mobile APP.

### 4.3 Unlock by PIN

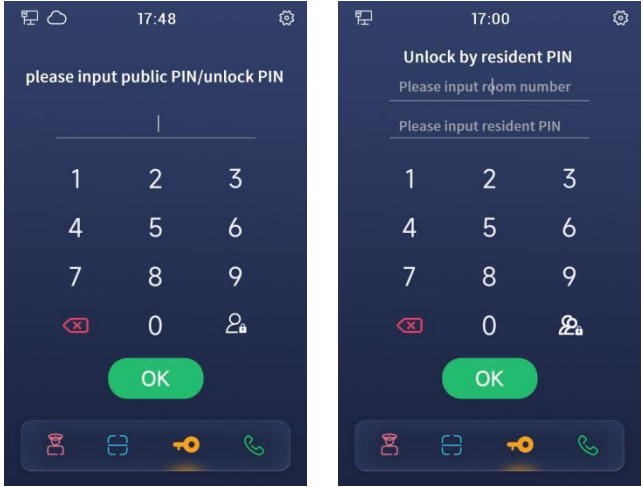



Interface of Unlock (public PIN/unlock PIN, resident PIN)

User clicks  on main screen and enters public PIN/unlock PIN/resident PIN.

- ① Public PIN: The door will be unlocked when user enters public PIN and it is recognised as correct. The default public PIN is 666666, which can be changed in "Setting - Unlock Setting".
- ② Unlock PIN: The door will be unlocked when user enters unlock PIN and it is recognised as correct. The unlock PIN is generated by mobile APP.
- ③ Resident PIN: The door will be unlocked when user enters room number&resident PIN and they're recognised as correct. The default resident PIN is 666666, which can be changed in Indoor Monitor. For example, if a resident lived in Block 1, Unit 1, 101, uses resident PIN to unlock the door by Outdoor Station at Block 1, Unit 1, then enter the room number 101 and the password 666666.

**Note:**

- ① Click  to switch from public PIN/unlock PIN screen to resident PIN screen, and can click  again to switch back. Public PIN unlocking, unlock PIN unlocking and resident PIN unlocking can all be switched on or off in Setting.
- ② When the Outdoor Station is used as a villa outdoor station and users can use resident PIN to unlock the door, there is no need to enter room number, only the resident PIN.
- ③ No unlock PIN unlocking function in No Server Mode.

## 4.4 Calling

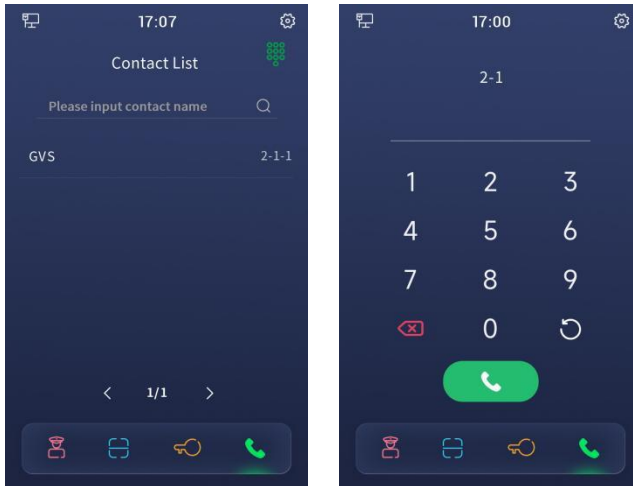

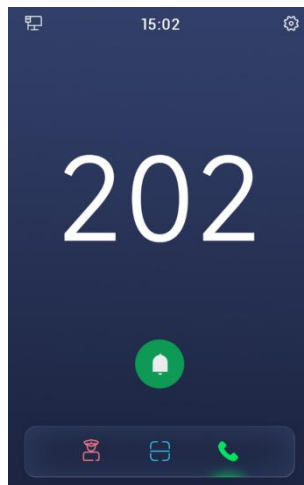

*Interface of Contact List (outdoor station/gate station), Interface of Dialing (outdoor station/gate station)*



*Interface of Dialing(villa outdoor station)*

(1) When the device is used as an outdoor station/gate station, visitors can call corresponding household through Contact List by clicking  on main interface.

Click  in the top right corner to switch from Contact List screen to Dialing screen, where visitor can call corresponding household by entering room number.

(2) When the device is used as a villa outdoor station, visitors can click on Call button directly without entering room number by clicking  on main interface.

**Note:**

- ① If the resident is online, device will ring back, and if the resident does not answer after 30s, the call will automatically end; if the resident is not online, device will not ring back, indicating no answer.
- ② Both Contact List calls and Dialing calls can be switched on or off in Setting page.
- ③ When Outdoor Station connects to Guard Unit or Indoor Monitor, the Guard Unit or Indoor Monitor can control to unlock the Outdoor Station.

# Chapter 5 Setting

Click  in the top right corner of main interface to enter into engineering setting page---- input password “801801”(default engineering password), entering General Setting interface.

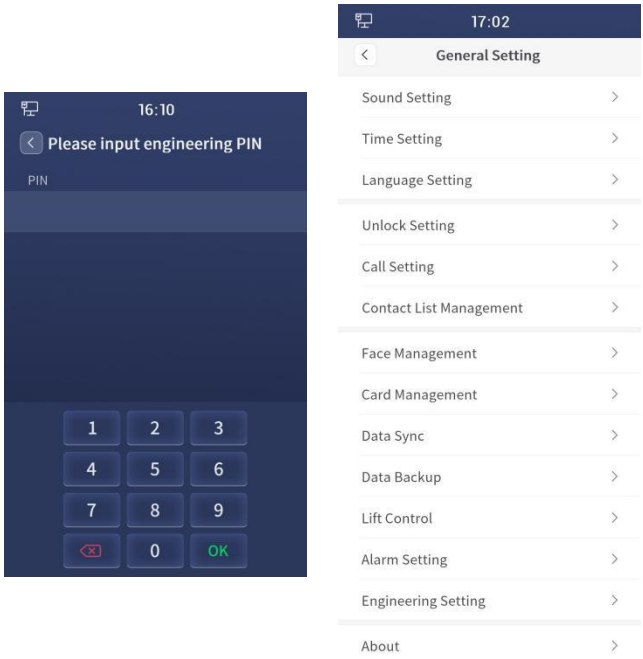

*Login interface of Setting*

## 5.1 RingTone Setting

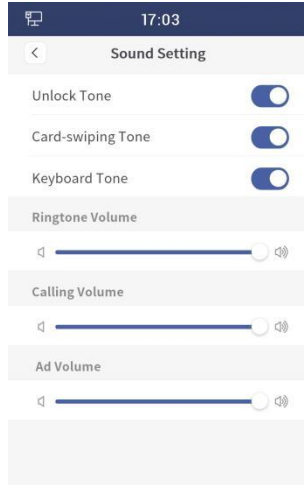

*Interface of Sound Setting*

- (1) **Unlock Tone:** When it is switched on, there will be an audible feedback when the door is unlocked.
- (2) **Card-swiping Tone:** When it is switched on, there will be an audible feedback when user swipes the card.
- (3) **Keyboard Tone:** When it is switched on, there will be an audible feedback on the device's tapping actions.
- (4) **Ringtone Volume:** The volume level of ringtone can be adjusted.
- (5) **Calling Volume:** The volume level of call can be adjusted.
- (6) **Ad Volume:** The volume level of advertisement can be adjusted.

## 5.2 Time Setting

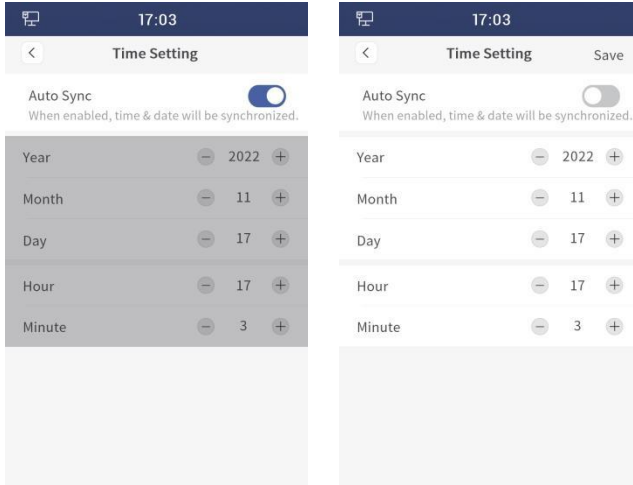

*Interface of Time Setting*

(1) **Auto Sync:** When it is turned on, the device will automatically synchronise network date and time, and manual setting option will not be available.

(2) **Manual Setting:** Turn off Auto Sync and you can set the year, month, day and hour of device manually.

## 5.3 Language Setting

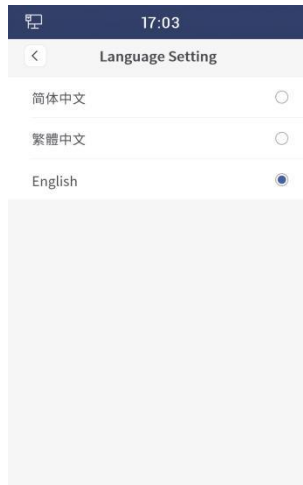

*Interface of Language Setting*

(1) **Available Languages:** Simplified Chinese, Traditional Chinese, English.

## 5.4 Unlock Setting

(1) **Unlock by face recognition:** When it is turned on, users with registered faces can unlock the door with face recognition through device camera.

(2) **Unlock by card:** When it is turned on, users can unlock the door by placing registered access card close to card swipe area on device.

(3) **Unlock by QR code:** When it is turned on, users can scan unlock QR code generated by mobile APP to unlock the door at "Main Interface - Unlock by face recognition&QR code".

Note: This function is not available in No Server Mode.

(4) **Unlock PIN :** When it is turned on, users can unlock the door by entering unlock PIN at "Main Interface - Unlock".

Note: This function is not available in No Server Mode.

(5) **Unlock by resident PIN :** When it is turned on, users can unlock the door by entering room number and resident PIN at "Main Interface - Unlock".

(6) **Unlock by public PIN :** When it is turned on, users can unlock the door by entering public PIN at "Main Interface - Unlock".

(7) **Public PIN Setting :** Public PIN can be changed.

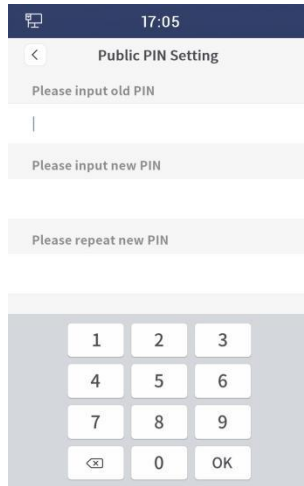

*Interface of Public PIN Setting*

(8) **Unlock by face&card:** When it is turned on, the device will be unlocked by both correct face recognition and card.

Note: This function is not available in No Server Mode.

(9) **Unlock by face&public PIN:** When it is turned on, the device will be unlocked by both correct face recognition and correct public PIN.

Note: This function is not available in No Server Mode.

(10) **Unlock time:** The duration of door unlocking can be modified to automatically close after timeout. The available time range is 5 seconds ~ 30 seconds.

## 5.5 Call setting

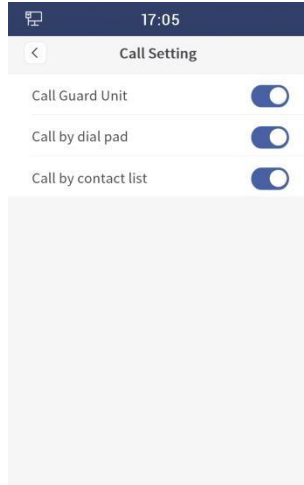

*Call setting interface*

(1) Call management center: After turning on this option, turn on this function on the main interface and click Call Management Center.

(2) **Dial call:** After turning on this option, turn on this function on the main interface, and enter the room number to call the corresponding household.

(3) Name list call: After turning on this item, turn on this function on the main interface, and click the name list to call the corresponding household.

**Note:** When the device is used as a Villa outdoor station, there is no name list call function, and the function switch is invalid. The dial-up call feature can only call a fixed room number.

## 5.6 Contact List Management

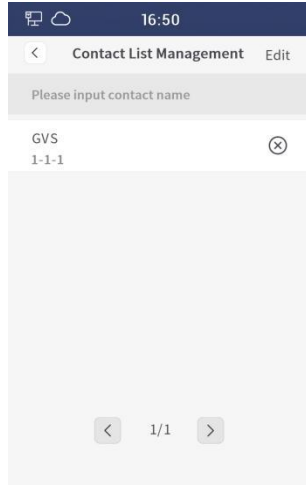

Contact List Management Interface

- (1) Check: Enter the contact name in the search box, and the list below will display the searched contact information.
- (2) Name list: In this list, you can view contact name and corresponding room number information.
- (3) Editing: Includes a switch to show the contact avatar, add a contact (room code + name), and clear the name list.

Note: Adding contacts can also be imported through the configuration tool, you need to turn on "Allow data transfer"

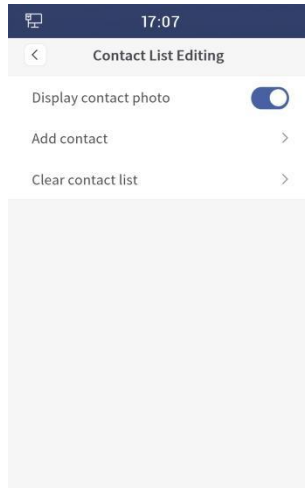

*Contact List Editing Interface*

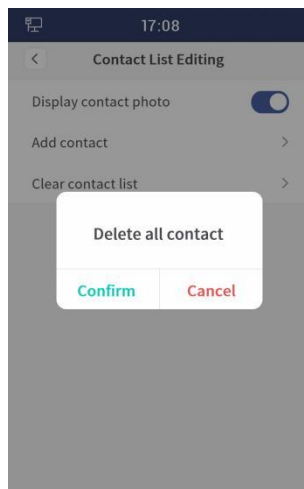
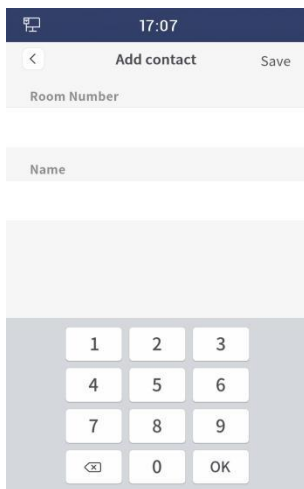

*Add contact interface & Delete all contact interface*

## 5.7 Face management

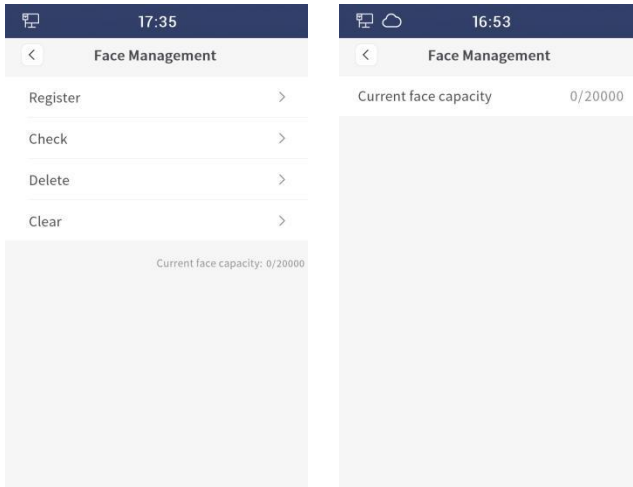

*Face management(in server-less mode)    face management interface (local/cloud)*

(1) In no server mode, you can register, check, delete, and clear face information on the device. Face data can be backed up and synchronized. The maximum storage capacity is 20,000 sheets.

- ① Registration: In the face registration interface, enter the face name first, click OK, enter the face input interface, and prompt "registration successful" to be successful entry.
- ② Check: Enter the face name in the search box to check the corresponding face information.
- ③ Delete: Enter the face name in the search box to delete the corresponding face information.
- ④ Clear: After the second confirmation, the face data of the device can be erased.

(2) In local server mode and CVM mode, you can only view face information, and cannot register, delete, or clear it. Face data can be transferred to the management machine and management platform.

- ① Check: Enter the face name in the search box to query the corresponding face information.

## 5.8 Access card management

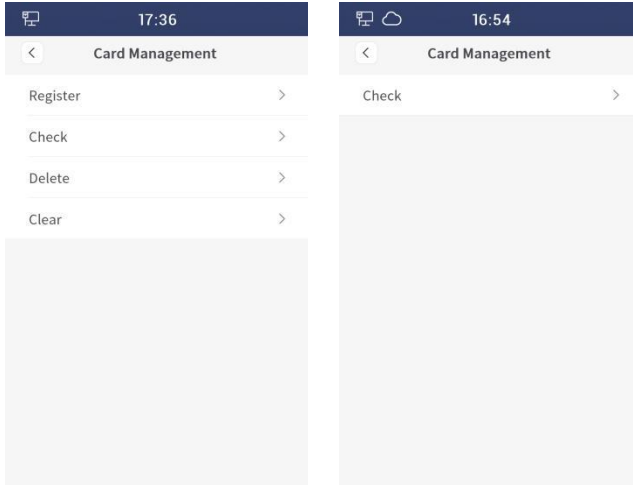

*Car Management interface(No Server) , Access card management interface (local/cloud)*

( 1 ) In no servers mode, you can register, check, delete, and clear the access card information on this device. Access card data can be backed up and synchronized. The maximum storage capacity is 20,000 sheets.

- ① Registration: In the card registration interface, swipe the card or enter the card number, select the card type (resident card/administrator card), click OK, and prompt "registered successfully" to be successful register the card.
- ② Check: By swiping the card or entering the card number in the search box, you can check the corresponding access card information.
- ③ Delete: You can delete the corresponding access card information by swiping the card or entering the card number in the search box.
- ④ Clearing: After the second confirmation, the householder/administrator card data of the device can be erased.

( 2 ) In local server mode and cloud server mode, you can only view access card information, and cannot register, delete, or clear it. Access card data can be transferred to the management machine and management platform.

- ① Check: By swiping the card or entering the card number in the search box, you can query the corresponding access card information.

## 5.9 Data synchronization (no server mode)

The data synchronization function on the device can only be used in the no server mode, and is mainly used to transfer card data and face data on this device to another device. The user needs to enter the region and device number of the target device, select the device type (Outdoor Station/Gate Station) and data type (card data, face data), and after clicking Sync, prompt "Sync Successfully" indicate it is done successfully.

Note:

- ① When selecting the equipment type as a Gate Station, you only need to enter the equipment number.
- ② On the About page, you can view the region to which the device belongs and the device number.

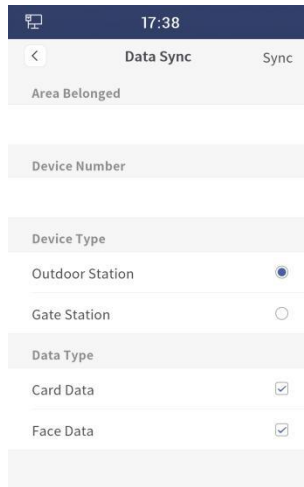

*Data Sync Interface*

## 5.10 Data backup (No Server Mode)

The data backup function on the device can only be used in the no-service mode, which is mainly used to upload the card data and face data on the device to the PC or download the card data and face data from the PC. The user needs to enter the computer IP address in the device and select the data type (card data, face data). After connecting the device with the computer, the card data and face data can be copied from the device to the PC, and the card data and face data can also be copied from the PC to the device.

Note: Please refer to the appendix for specific steps.

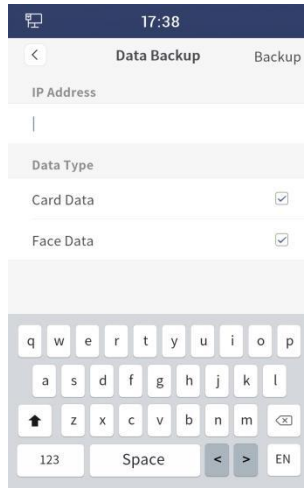

*Data Backup Interface*

## 5.11 Lift Control

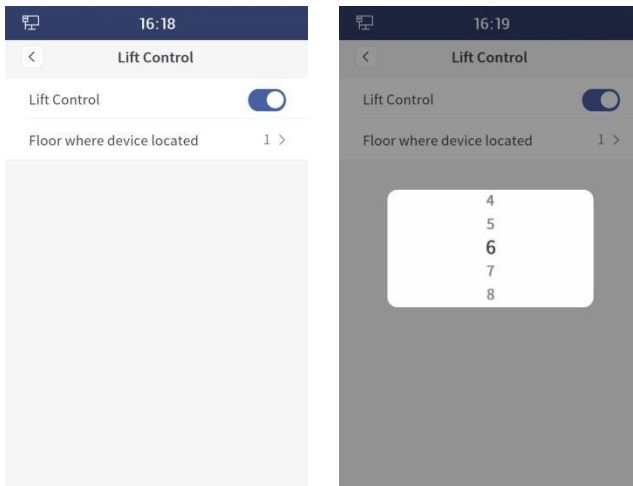

*Lift Control Interface*

( 1 ) Life control: After opening this item, open the door and unlock it through face recognition, card swiping, unlocking code, and user password.

( 2 ) Floor where the device is located: Select the floor where the device is located. Optional range: -8 ~ 64 floors, except 0.

## 5.12 Alarm Setting

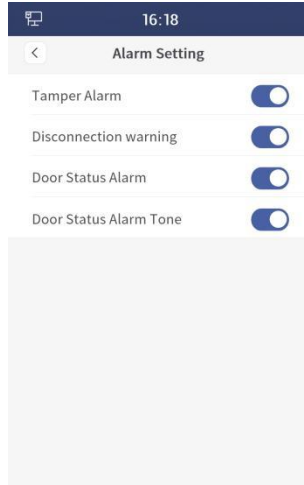

*Alarm setting interface*

- (1) Tamper alarm: After turning on this option, if the device is removed by external force, the device will beep and the management center will receive an alarm notification.
- (2) Disconnection alarm: When this option is enabled, if the device is disconnected, the device will beep and the disconnection icon will be displayed in the status bar.
- (3) Door status alarm: After this option is turned on, if the device detects that the door has been open for more than 120 seconds, the device will send an alarm signal to the management center.
- (4) Door status alarm: When this option is turned on, the door status alarm will have audible feedback.

## 5.13 Engineering Setting

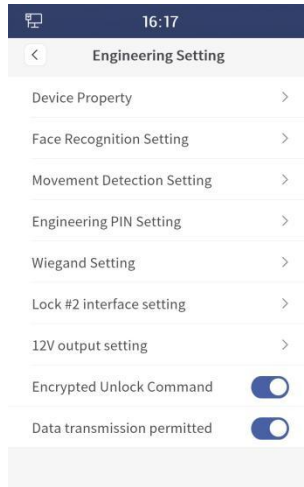

*Engineering setting interface*

### 5.13.1 Device Property

Select the type of equipment (Outdoor Station, Villa Outdoor Station, Gate station) according to the actual installation location of the current equipment. After selecting the equipment type, the door machine needs to enter "building number - unit number - code number", the Gate Station needs to enter "Code Number", and the Villa Outdoor Station needs to enter "building number - unit number - apartment number - code number".

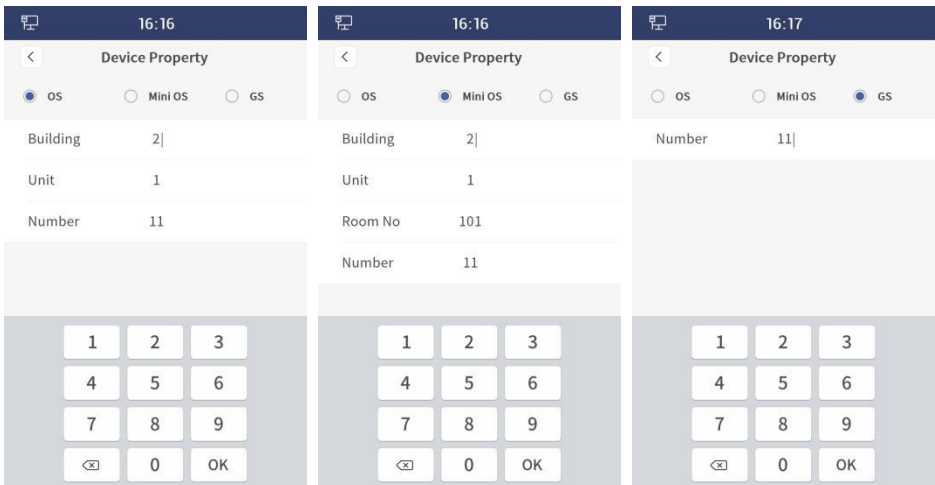

*Device property interface(Outdoor Station,Mini Outdoor Station,Gate station)*

### 5.13.2 Face Recognition Setting

Face recognition settings include: face anti-spoofing, threshold value, camera wake-up distance adjustment.

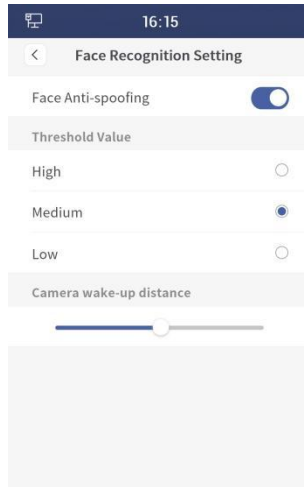

*Face recognition setting*

- (1) Face anti-spoofing: When this option is turned on, the device performs live detection, and non-living registered faces cannot be successfully unlocked.
- (2) Threshold value: Face recognition threshold (high, medium, low), the degree of matching of different levels corresponding to face recognition. Set the threshold to high, and the face matching degree is relatively high when face recognition is performed. Set the threshold to low, and the face matching degree is relatively low when face recognition is performed.
- (3) Camera wake-up distance adjustment: The farthest distance for the user to wake up the camera can be adjusted. The wake-up distance is 0.3~2m. If the camera wake-up distance is set to the maximum, within a range of 2m, the device recognizes a face and enters the face recognition interface.

### 5. 13. 3 Movement Detecting Setting

Motion detection settings include: switching, sensitivity adjustment, sensitivity test.

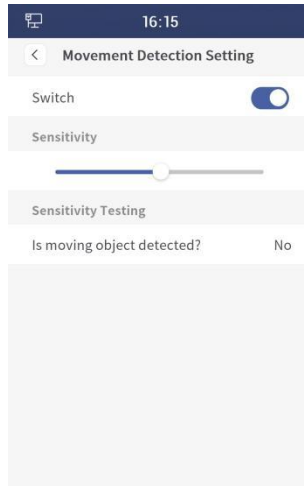

*Movement Detecting Setting Interface*

(1) Switch: When this option is turned on, the device camera will detect motion. If the moving object is close to the door station, the door station lights up the screen and enters the main interface. If the device detects a face, it enters the face recognition interface.

(2) Sensitivity adjustment: The detection sensitivity of the device camera to the movement of the human body can be adjusted.

(3) Sensitivity test: Whether the device camera detects that an object is moving within the detection range. If an object moves, it displays "Yes"; If no object moves, "None" is displayed.

#### **5. 13. 4 Engineering PIN Setting**

The engineering password can be modified, and the password length is 6 digits.

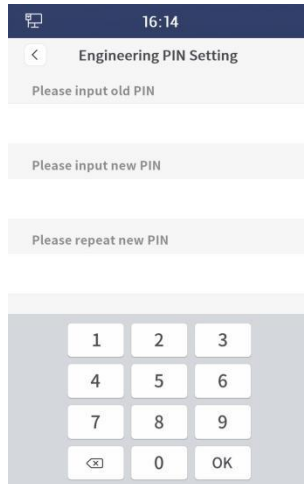

*Engineering PIN setting interface*

### 5. 13. 5 Community Code Setting

In cloud server mode or local server mode, it can be manually entering the community identification code or clicking the "Configured" button, the device scans the community QR code to associate the device to the corresponding community.

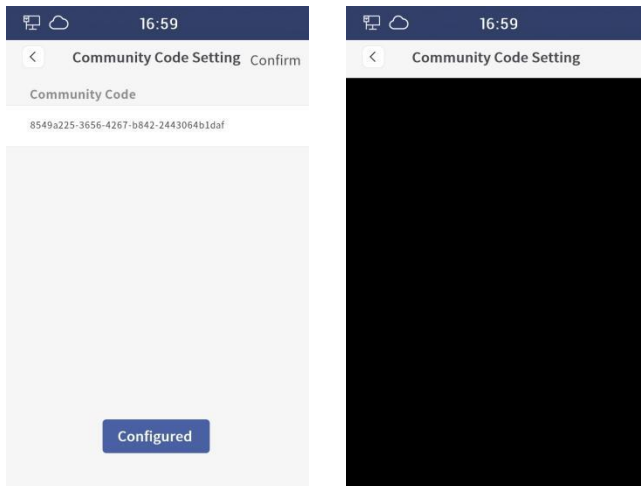

*Community code setting interface*

### 5. 13. 6 Wiegand Setting

Wiegand settings can be performed, including: switch, bit selection (26-bit, 34-bit),

sequence selection (forward and reverse sequence).

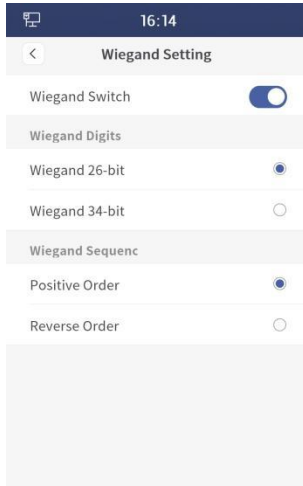

*Wiegand setting interface*

### 5. 13. 7 Lock #2 Interface Setting

Optional Lock2 interface functions, including: alarm output, electric lock control, doorbell control

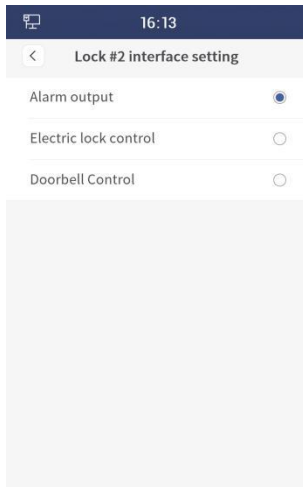

*Lock2 interface setting*

### 5. 13. 8 12V output setting.

You can choose whether to output 12V voltage. Select the output 12V voltage, and the

Lock2 interface function will take effect.

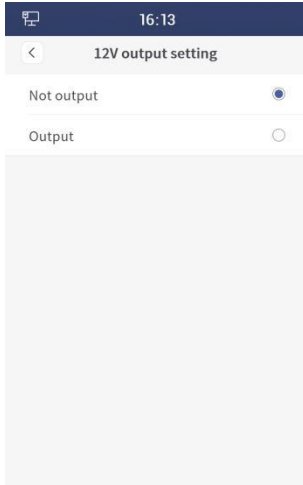

*12V output setting interface*

### 5. 13. 9 Group Call Setting

If this parameter is enabled, the device calls all management machines in the same building by default.

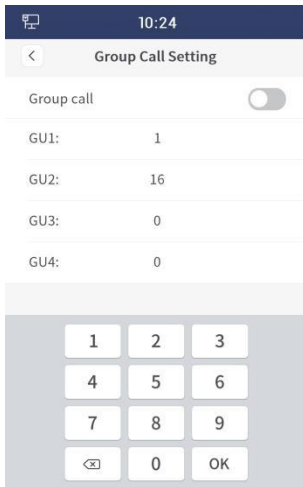

*Group call setting interface*

### 5. 13. 10 Device Lock Setting

You can set the device lock countdown time and unlock password. After the function is enabled, the device will be locked at the end of the countdown, and basic functions of the device will be unavailable.

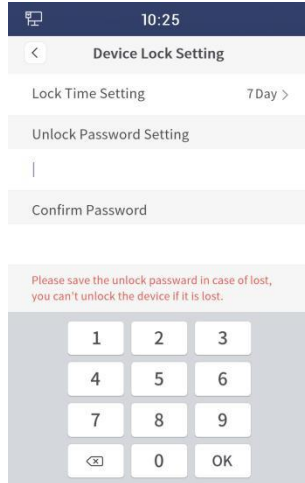

*Device lock Setting interface*

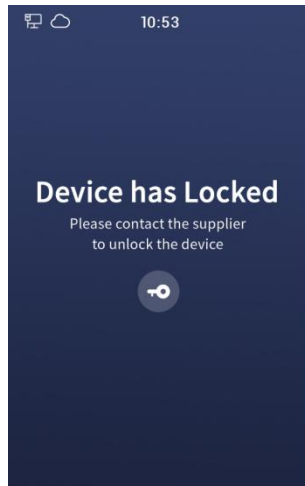

*Device lock interface*

### 5. 13. 11 Automatic Time Adjustment Settings

After this option is enabled, the device synchronizes time with other devices in the system after selecting the automatic time correction time frequency.

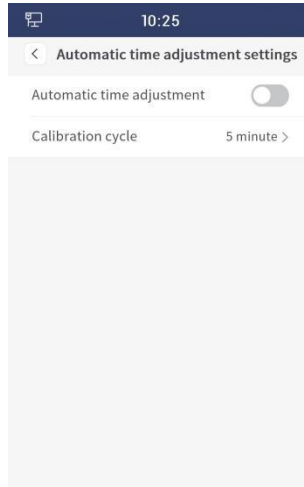

*Automatic time setting interface*

### 5. 13. 12 Encrypted unlock instructions

When this option is turned on, the device enables the encrypted unlock command

### 5. 13. 13 Allow data transfer

When this option is turned on, the device will allow data transfer. Allows sending and receiving data for contacts, faces, access cards. In no server mode, data backup and restoration can be performed; In local server mode and cloud server mode, data can be transferred to the guard unit and management platform.

## 5.14 About

### 5. 14. 1 Setting Information.

Displays the relevant information of the device, including: region, device number, software version, MCU version, IP address, MAC address, and SIP account.

Note: In CVM mode or local server mode, the SIP account information is displayed only

after the cell information is configured.



*About interface*

### 5. 14. 2 Device rebooted

Click this option to confirm the reboot, and the device will restart.

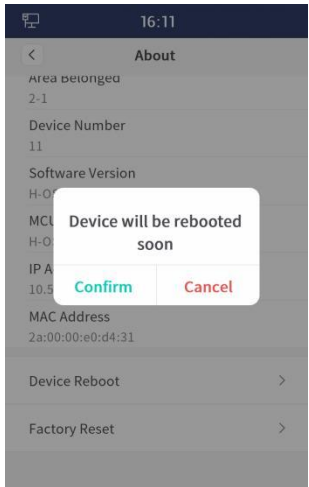

*Device rebooted interface*

### 5. 14. 3 Factory data resetting

After clicking this option, after the confirmation, the device will execute the factory reset and the user needs to reconfigure it.

**Note:**

- ① Factory reset within 60s of power-on, all data in the device is restored to default, and the user needs to re-select the language and working mode.
- ② After 60s of power-on, the factory settings are reset, and all data in the device is restored to default, and the user only needs to select the language again.

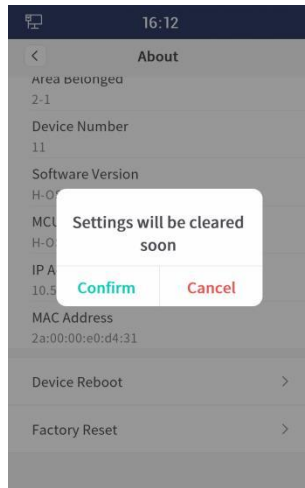

*Factory reset interface*

# Chapter 6 Appendix

## 6.1 Procedure for data backup

(1) Copy from device to PC (Figure 1)

- 1.Select “Tftp Server”
- 2.Current directory: Click the "Browse" button and select the path. The card data and face data are copied to this folder.
- 3.Server interfaces:Click the drop-down button to select the IP address of the computer.
- 4.In the "Data Backup" interface of the device, enter the IP address of the computer, select the data type (card data, face data), and click the "Backup" button in the upper right corner.
- 5.After the data transfer is completed, the folder on the PC (the folder path selected in step (2)) will appear in the .cnf format, which means that the copy is successful.

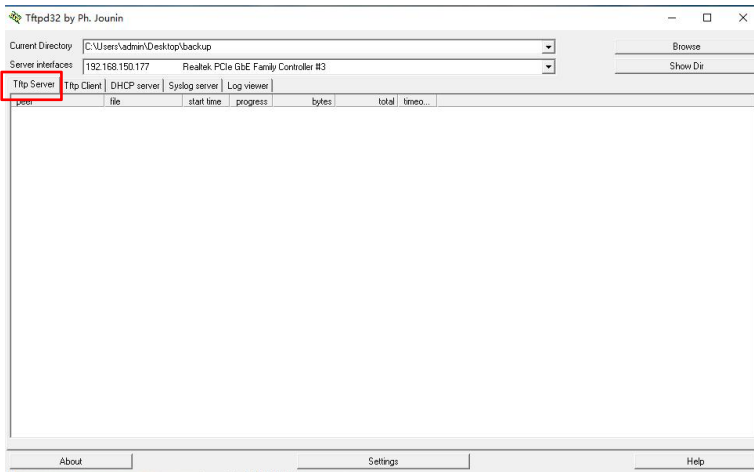

Figure 1 data upload interface

(2) Copy from PC to device (Figure 2)

- 1.Select “Tftp Client” .
- 2.Host: input the device IP address, can be review the “About” interface to see the device IP address.
- 3.Port: input “69”.
- 4.Local file: click“...”button,select the file in .cnf format.Need to start with the .cnf file with the serial number 0, select a file, click the "Put" button, and repeat this behavior in order.

5. After the data transfer is completed, the corresponding information can be seen in the "Access Card Management" and "Face Management" interfaces on the device, which means that the copy is successful.

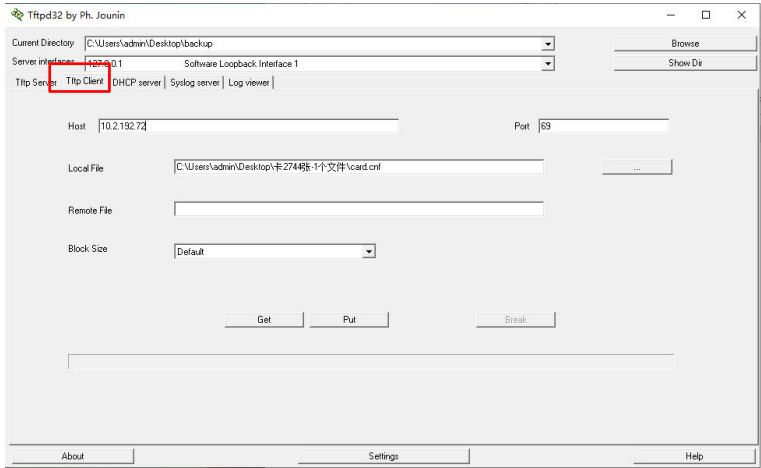

Figure 2 download interface

## 6.2 Procedure for local upgrade

Please turn off the computer firewall before use.

- ① Select the appropriate IP address of the computer.(need to be in the same network segment as the device), and click "Connect".
- ② Click the "Open" button and select the upgrade file.
- ③ In the device input box, enter the device model and click "Search"
- ④ Select the device and click "Upgrade"

Lightning

192.168.150.188 Connect

C:\Users\admin\Desktop\H-OS18\_MAIN\_V0.6.6\_20220808.bin Open

Customer:  Device:  Search

IP:10.16.128.56  
MAC:1c:87:76:85:e0:1d  
IP:10.16.128.64  
MAC:26:d6:6a:bd:e4:45  
IP:10.2.192.40  
MAC:2a:00:00:e6:d4:31  
IP:10.2.192.0  
MAC:1c:87:76:85:e0:36  
IP:10.5.128.40  
MAC:2a:00:00:e0:31:d4  
IP:10.5.128.64  
MAC:1c:87:76:85:e0:10

Upgrade

*Local upgrade interface*