

User Manual

Outdoor Station

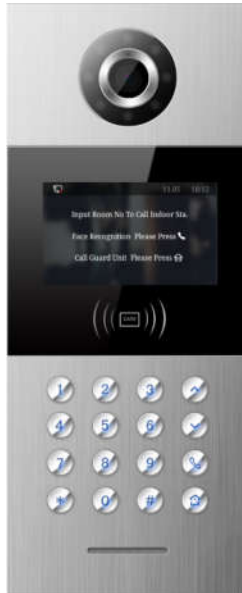

H Series - Outdoor Station With Face Recognition
User Manual_V1.0
Model Number: H-OS09S

Attentions

1、 Please keep devices away from strong magnetic field , high temperature , wet environment ;



2、 Please do not fall the devices to the ground or make them get hard impact ;



3、 Please do not use wet cloth or volatile reagent to wipe the devices ;



4、 Please do not disassemble the devices.

Content

Chapter 1 Overview	1
1.1 Functions and Characteristics	1
1.2 Parameters	1
Chapter 2 Appearance and Interface	2
2.1 Front View	2
2.2 Product Dimension	3
2.3 Rear View	4
Chapter 3 Installation	5
3.1 Installation Illustration	5
3.2 Installation Height	6
Chapter 4 Operation Instructions	7
4.1 Call Indoor Monitor	7
4.2 Call Guard Station	7
4.3 Unlock	7
4.4 Face Registration and Management	9
Chapter 5 Setting	12
5.1 Standby Interface	12
5.2 Login Setting Interface	12
5.3 Setting Interface	12
Chapter 6 System Setting	13
6.1 Volume Setting	13
6.2 Time Setting	14
6.3 Language Setting	14
6.4 Unlock Setting	15
6.5 Card Management	15
6.6 Unlocking Duration	17
6.7 Wiegand Setting	18
Chapter 7 Config. Setting	19
7.1 System Property	19
7.2 Device Property	22
7.3 Face Recognition Setting	23
7.4 Config. Password	24
7.5 Proximity Detection	25

7.6 Community Code Config25
7.7 Help 26
7.8 Factory Test 26

Chapter 1 Overview

The Outdoor station is one of the main parts in digital video door phone system .It's connected with Indoor Monitor, Guard Unit and other devices in the system by standard CAT5 cable.It supports human approach detection, face recognition unlock and RFID (IC) access control.

1.1 Functions and Characteristics

- 4.3" TFT LCD display
- Support IC Card
- Auto fill light with high luminance LED
- Door status detection, timeout alarm
- High level of dustproof and waterproof performance
- Support normally-closed / normally-opened unlock
- Provide 12V / 800mA DC output (when input voltage > 18V)
- Support face recognition unlock

1.2 Parameters

Working Parameters

System:Android 6.0.1

CPU:Allwinner A64 4-Core,Basic Frequency 1.5GHz

RAM:1GB DDR3

ROM:8GB eMMC, Plus to 128GB Via TF Card

Face Storage:10000

Working Voltage:DC 24V

Static Current:≤ 200mA

(Independent power supply only)

Working Current:≤ 300mA(not including 800mA power supply for unlocking and 320mA for heating plate)

Environment Temperature:-40°C ~ +70°C

Camera

Camera Type: CMOS

Pixel: 2 Mega Pixels

View Angle: diagonal 123°

Focal distance: 3.5mm

LED: white light

Minimum Illumination: 0 lux

Display

Type: LCD

TFT Screen Size: 4.3"

Resolution: 480×272

Product Dimension: (W/H/D) 148.5×363×47mm

Chapter 2 Appearance and Interface

2.1 Front View

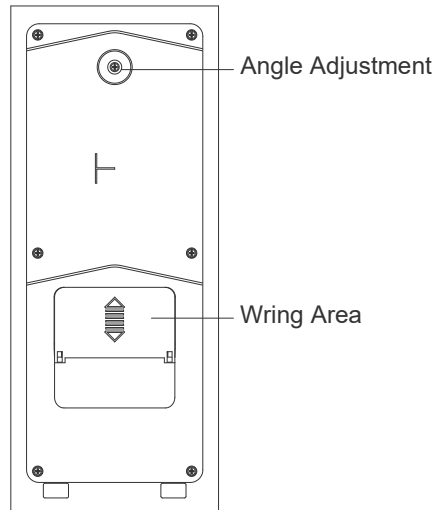
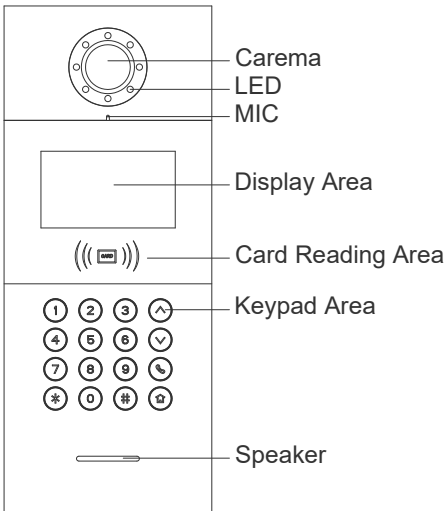

2.2 Product Dimension

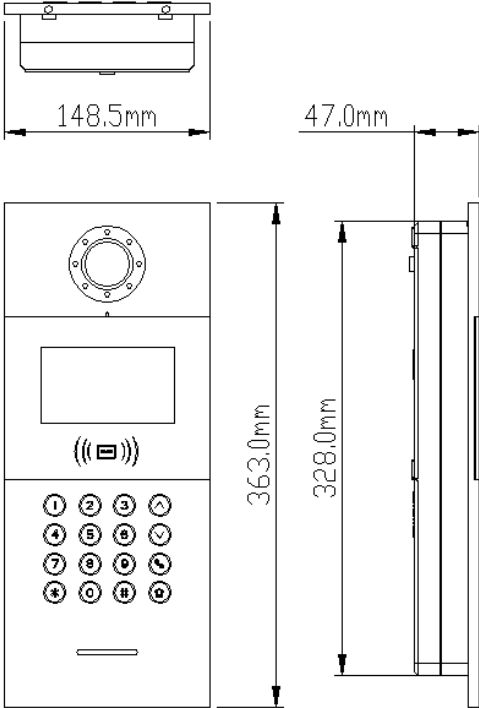

2.3 Rear View

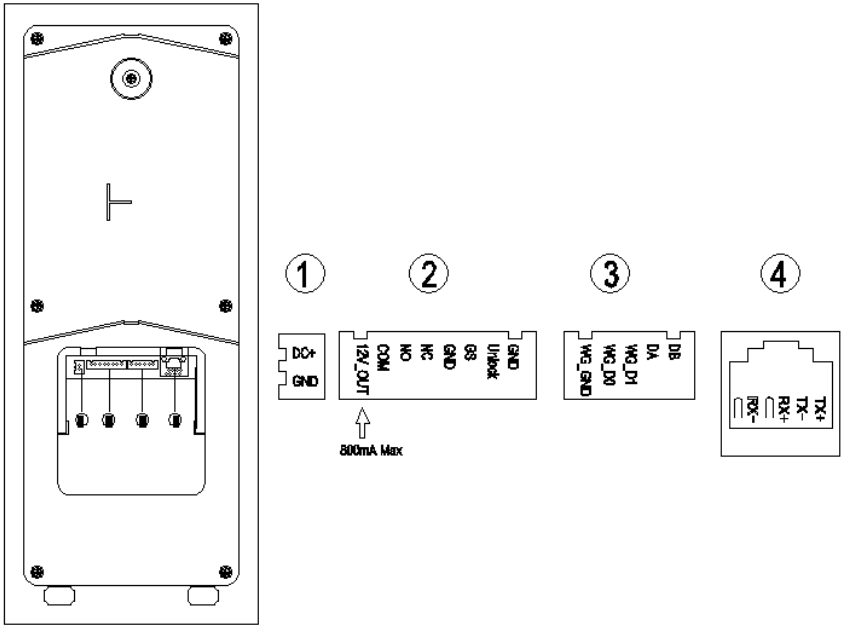

① Interface for power supply: DC 24V (interface for independent power supply, working voltage DC: 18-30V)

② +12V: Only when the Outdoor Station input voltage > 18V, +12V is given.

COM, NO, NC: Common pin, normally-open pin, and normally-closed pin.

GS: Door status detection.

UNLOCK GND: Unlock Push Button interface.

③ WG-GND, WG-D0, WG-D1: Wiegand interface.

DA, DB: RS485 interface.

④ Network Interface. (Support standard PoE 48V power supply. If power supply for door lock or low-temperature heating function is required, the outdoor station must use independent power supply, which depends on the actual model.)

Chapter 3 Installation

3.1 Installation Illustration

Step 1: Put the embedded box into the preformed groove. After getting the cable out through the opening, fasten the box with nails or by cement. Embedded box dimension (W/H/D) :132×340×50 mm

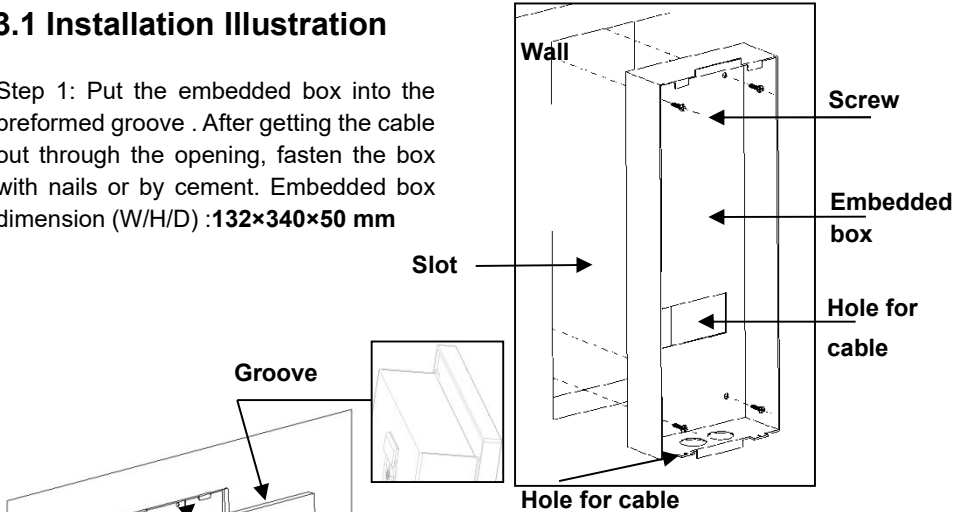

Step 2: After connecting the cable to the outdoor station, match the snap slot of the outdoor station to the snap of embedded box and push the outdoor station into the box, and keep it stable. After that, push the outdoor station upward to make the buckle clamp the embedded box buckle.

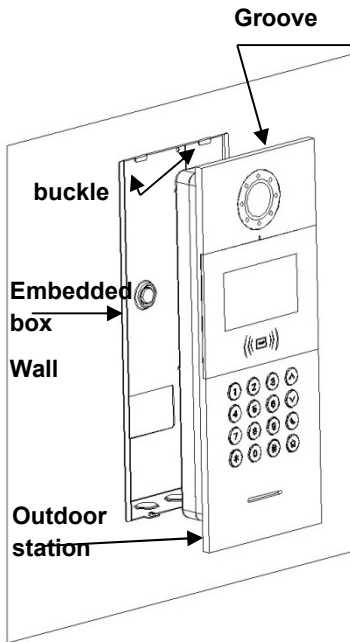

Step 3: Fix the screws at the bottom of the aluminium panel, and tighten to complete installation

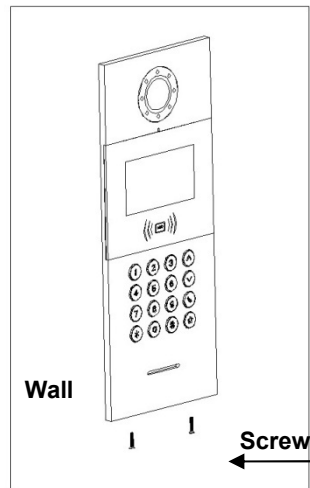

3.2 Installation Height

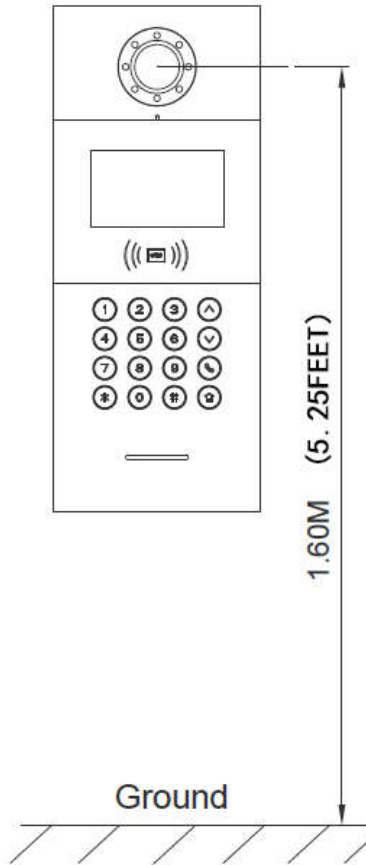

Recommended Installation Height: 1.6 meters

Chapter 4 Operation Instructions

4.1 Call Indoor Monitor

After inputting room number(like 0101) to start the call. it will have the ring-back tone during the call and press “*” to cancel the call.

If there is no any answer within 30 seconds, it will be ended automatically.

Remark: The room number of Gate Station is building(1 ~ 999)+apartment no (1-1900) ., like 011+0007.

4.2 Call Guard Station

At Standby mode, visitors can press  to call guard unit.

4.3 Unlock

4.3.1 Unlock via Wiping a Card

Take the registered card close to the card swiping area on the Outdoor Station/Gate Station to unlock the door.

4.3.2 Unlock by Push Button

There is an interface on the Outdoor Station/Gate Station that can wire to a button inside the door, which residents inside can just press and unlock.

4.3.3 Unlock by Password

1) Unlock by Public Password: # + Public Password + #

2) Unlock by User Password: * + # + room no. + User Password + #

Remark: This function is default close. Get into System Setting,then Unlock Setting, to open/close unlocking by password.

4.3.4 Unlock by Face

1) When visitor is approach to the Outdoor Station and face the camera, the Outdoor Station will automatically enter the face recognition interface.

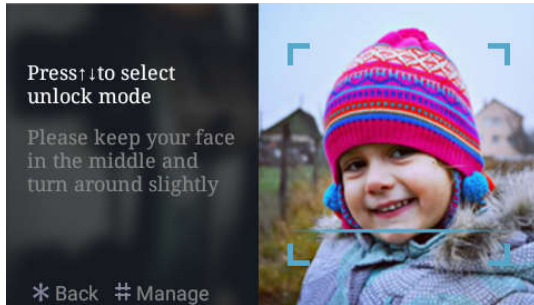

Interface of face recognition

2) For registered face, keep standing in the middle of the screen, if identified successfully, a pop-up message of "Door Opened" will appear.

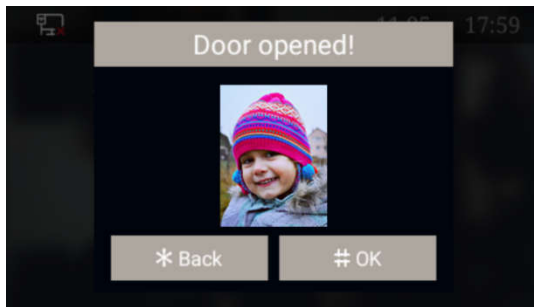

Interface of door opened prompt

Remark: Human body proximity detection is activated by default, enter Engineering Settings → Proximity Detection Setting interface, and you can choose to turn on or off Proximity Detection.

When Proximity Detection is turned off, press  to enter the face recognition interface.

4.4 Face Registration and Management

Residents can register and manage faces via this device or PC.

4.4.1 Face Registration via Outdoor Station

In Face Unlock Interface, click “ # ” to enter Face Registration Management, residents can choose using room number or user card for registration.

1.Register by room number

Residents input the correct room number and user password to enter the face registration interface.

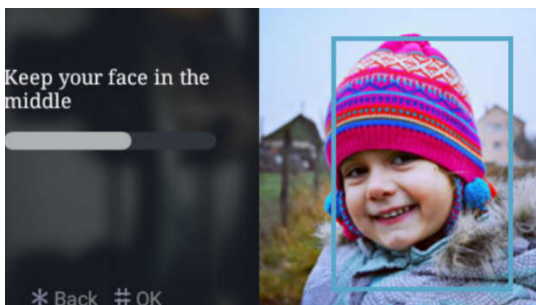
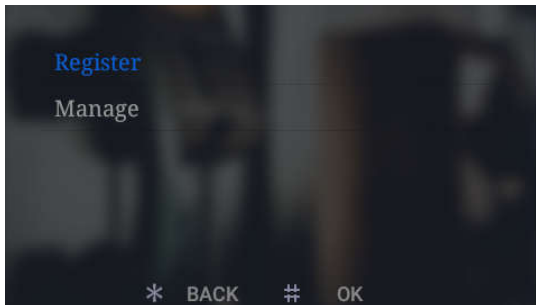
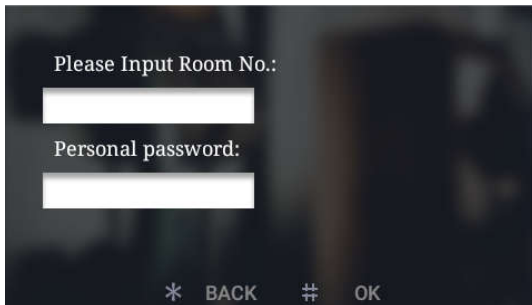

Interface of face registration

2. Register by swiping user card

Administrator can swipe the patrol card to enter the interface of administrator face registration.

Remark: This card should be authorized by PC Management Center in advance.

During the registration, please keep your face in the middle of the screen, a message “done” will be prompted when the face is successfully registered.

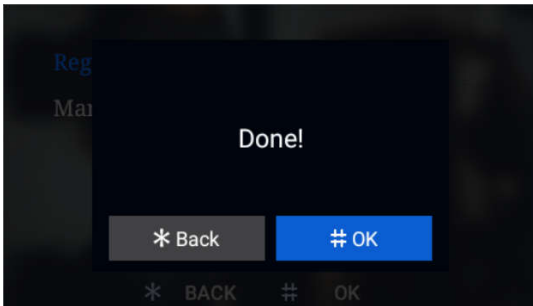

Interface of registered successfully

4.4.2 Face Registration via PC

Face Registration can also be done by PC management center (Resident Management --- Enroll resident) . Details please refer to <PC face synchronization manual>



4.4.3 Face Management

In Face Registration interface, click **Manage** to view the face list, user can press up and down button to check the registered face.

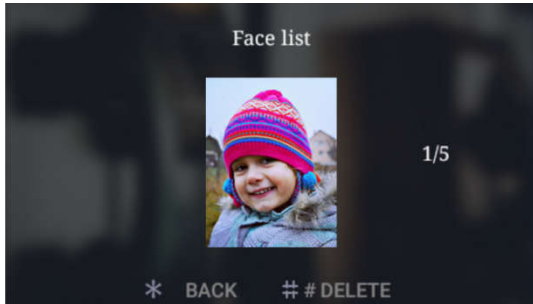

Interface of face management

Press “ # ” button to delete the registered face and “ * ” to return to the previous interface.

Chapter 5 Setting

5.1 Standby Interface

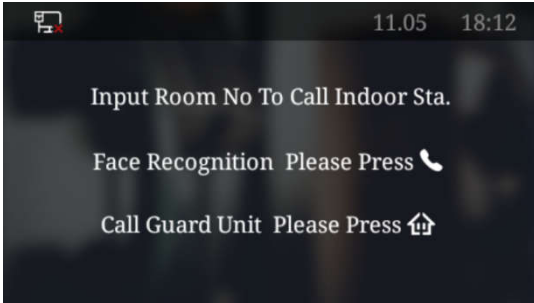

Standby Interface

5.2 Login Setting Interface

Press "#" and then "*" key, enter into the login interface of engineering settings.

Default password is "801801"

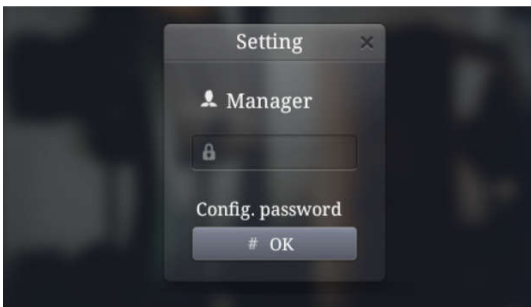

Login interface of settings

5.3 Setting Interface

Input the correct password then press "#" key to confirm and enter.

Press the up/down button to choose the item of setting and enter it.

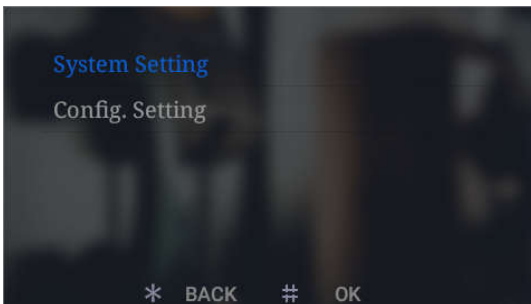

Interface of setting

Chapter 6 System Setting

System setting interface is shown as below, including Volume Setting, Date And Time Setting, Language, Unlock Setting, Card Management, Face Registration, Unlocking Duration and Wiegand Setting. Press the up/down button to choose each option and enter the corresponding setting interface.

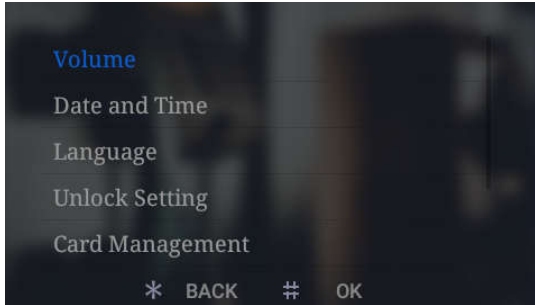

System setting interface

6.1 Volume Setting

Volume Setting interface is shown as below, users can press the up/down button to choose option and “#” to configure corresponding setting. After setting is done, press “#” to confirm or “*” to return to previous menu.

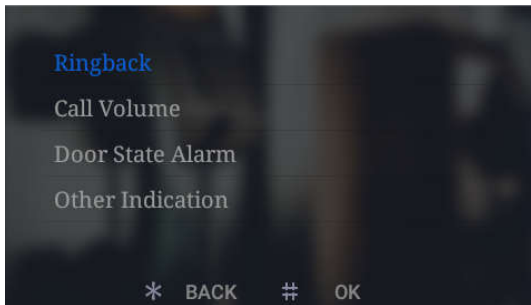

Volume setting interface

6.2 Time Setting

Time Setting interface is shown as below, users can press the up/down button to select each option and modify it's number. After setting is done, press “#” to confirm.

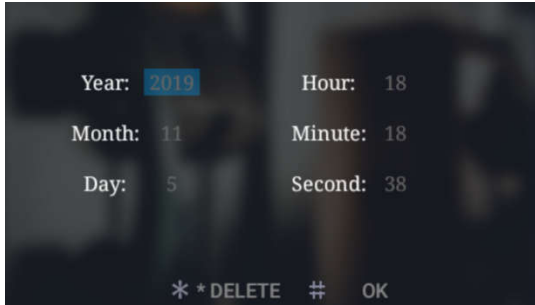

Date And Time interface

6.3 Language Setting

Language Setting interface is shown as below, users can press the up/down button to choose the language, then press “#” to confirm and return to previous menu.



Language setting interface

6.4 Unlock Setting

Unlock Setting interface includes: QR Code Unlock, Face Unlock, Random Password Unlock, Public Password Unlock and Public Password Modification. Users can press the up/down button to the corresponding interface . After setting is done, press “#” to confirm or “*” to return to previous menu.

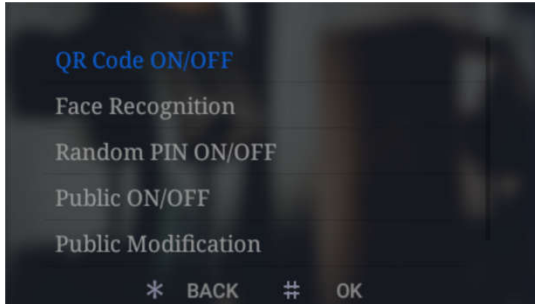

Unlock setting interface

6.5 Card Management

Card Management interface includes: User Card, Patrol Card, Copy Card Data and Card Copy Prevention.

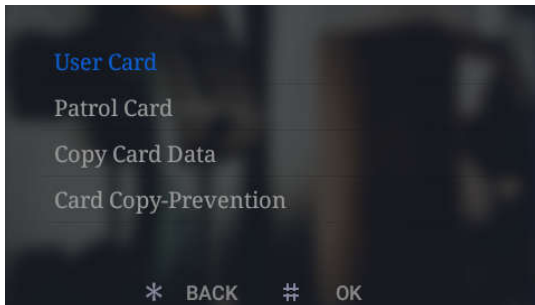

Card management interface

This manual is taking user card as example to introduce the related operations in brief. (operations of Patrol card is similar with user card's)

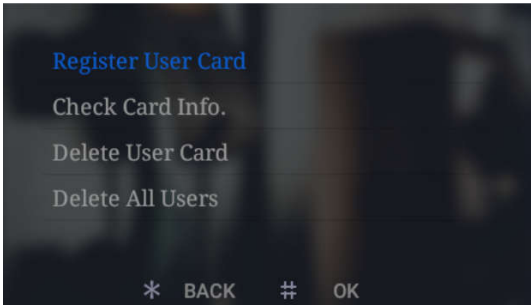

User card interface

- **Registration and Deletion**

In card registration interface, swipe a card or input the card numbers to register. After finishing registration, press “*” to return to previous menu. While inputting wrong numbers, press the deletion key “*” to delete each number. The operation of Card Deletion is same as Card Registration.

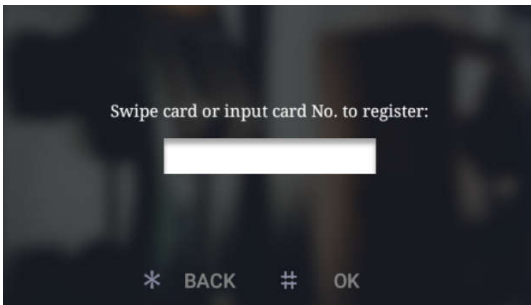

Card registration interface

Remark: Capacity of registered user and patrol card: 20000 cards maximum

- **Check Card Information**

Users can click **Check Card Info.** to check all card numbers and the quantity of the registered cards.

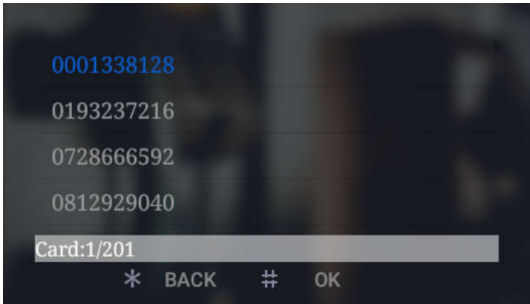

Card information interface

- **Delete All Users**

Click this option, a message will pop-up for confirming the operation (delete all?), press “#” to confirm and all users will be erased, or press “*” to return to previous menu.

- **Copy Card Data**

This function can let the user to copy the local card information to other Outdoor Stations or Gate Stations. Enter this interface, firstly choose the type of target device, an “•” icon will show behind the selected option, and input the device number of the target device. Then press “#” to confirm and begin the transmission, the result will be shown with a prompt message when the process is completed.

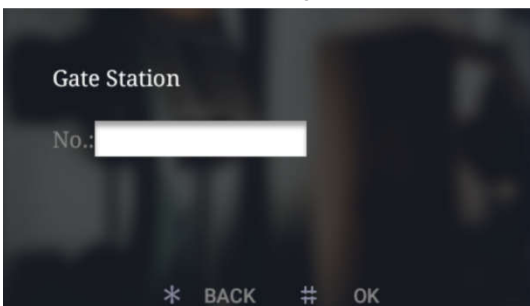

Interface of copy card data

- **Card Copy Prevention**

With this option turned on, the IC card will be encrypted when it swipes to Outdoor Station, which prevents card duplication.

6.6 Unlocking Duration

This option is meant to set the duration of door open time, the door will lock again automatically when the time is out. Input the during time(unit: second), then press “#”

to confirm and return to previous menu.

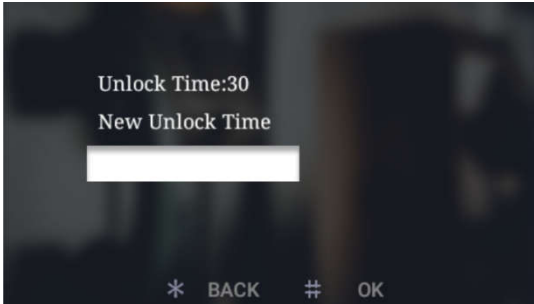

Interface of unlocking duration

6.7 Wiegand Setting

This function offers user to turn on/off Wiegand and set the sequence.

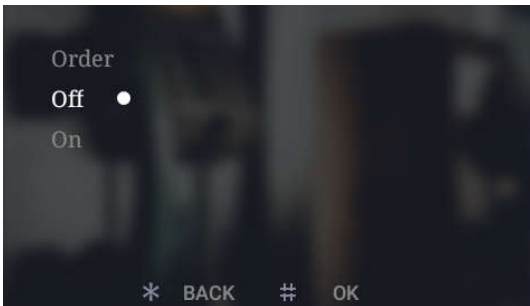

Wiegand setting interface

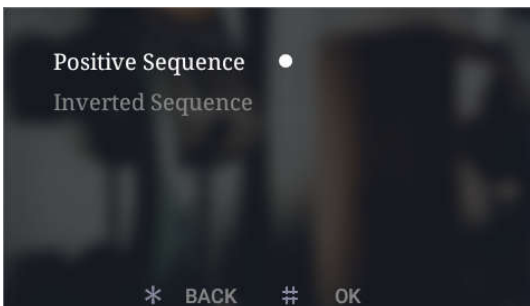

Sequence setting interface

Chapter 7 Config. Setting

Configuration Setting includes System Property, Device Property, Face recognition, Configuration Password, Proximity Detection, Community Code Config., Help and Factory Test. Press up/down button to enter the related setting.

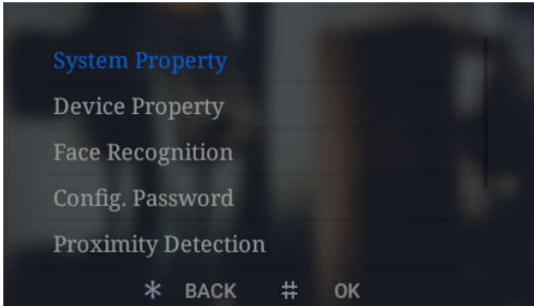

Configuration setting interface

7.1 System Property

System Setting interface is shown as below, including: Unit Dialing Digit Setting, Door State Alarm, Tamper Alarm and Auto Push. Press up/down button to enter related setting interface.

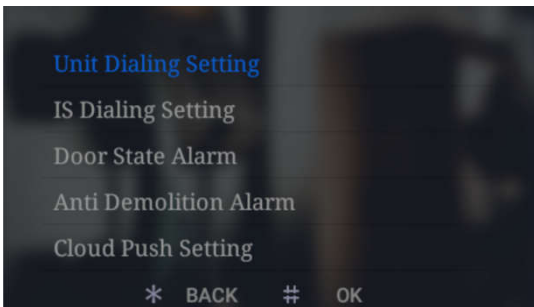

Interface of system property

● Dialing Digit Setting

The dialing digits setting shows different interface according to the different device property. While setting as Outdoor Station:

Choose “3”, the device will make the call automatically after inputting 3 numbers. For Number entered cannot exceed the defined parameter, when there's no enough number then a ZERO will be filled in front of the number. (Say the number is set as 2, while a 3 is entered only, then it will be filled as 03)

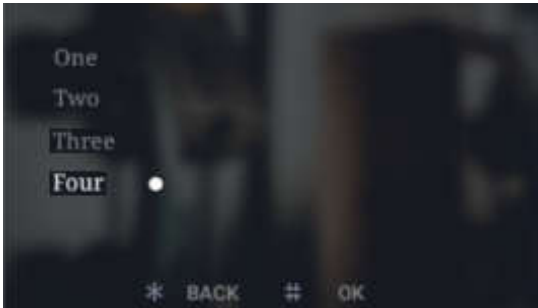

Interface of dialing setting

While setting as Gate Station:

Users can choose 1, 2 or 3 digits for dialing Building number, and choose 1、2、3 or 4 digits for dialing Indoor Monitor number. Related instruction please refer to the dialing Illustration shown as below.

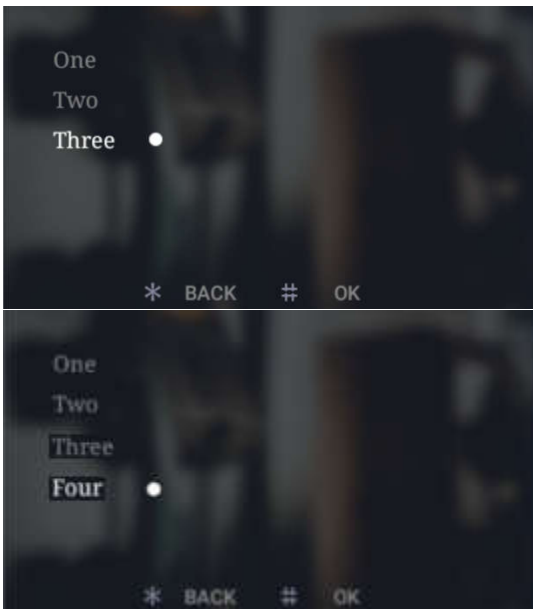

Interface of Gate Station dialing setting

Illustration of Units:

Digit number of building	1-digit	2-digit	3-digit
	1 digit of building No	2 digit of building No.	3 digit of building No.

Illustration of Indoor Monitor number:

Digit number of Indoor Monitor	1-digit	2-digit	3-digit	4-digit
	1 digit of room No.	2 digit of room No.	3 digit of room No.	4 digit of room No.

the rules of Gate Station dialing

- **Door Status Alarm**
- **Anti Demolition Alarm**

Users can choose to open/close each alarm. When the corresponding alarm is triggered, the device will send the alarm information to the administration center and PC.

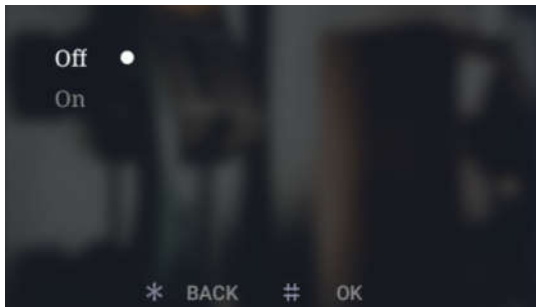

Interface of Door Status Alarm

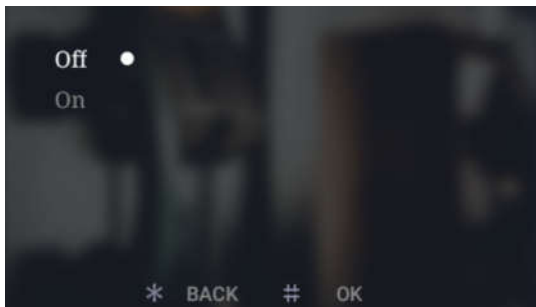

Interface of Anti Demolition Alarm

- **Auto Push**

To open or close the Auto Push for cloud intercom function.

7.2 Device Property

The device can either be used as Outdoor Station or Gate Station, depending on the definition of device property. Select the device type, an “•” icon will show behind the option, then press “#” to confirm.

If setting as Outdoor Station, the device will contain building number(1-999), and device number(1-16).

If setting as Gate Station, the device will only contain device number(1-32).

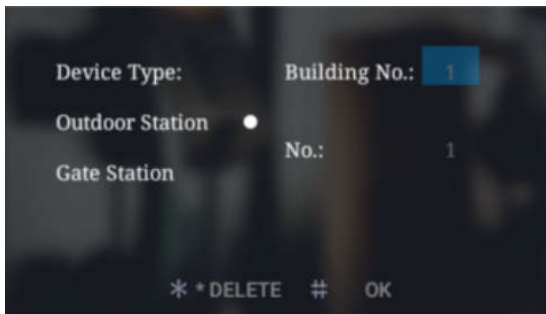

Interface of Outdoor Station property

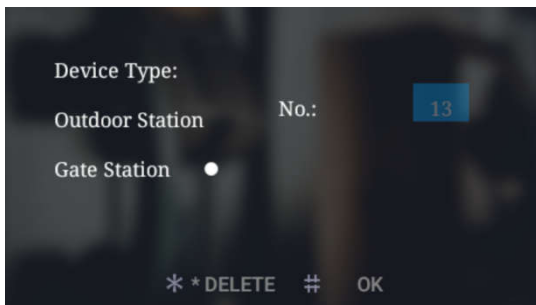

Interface of Gate Station property

7.3 Face Recognition Setting

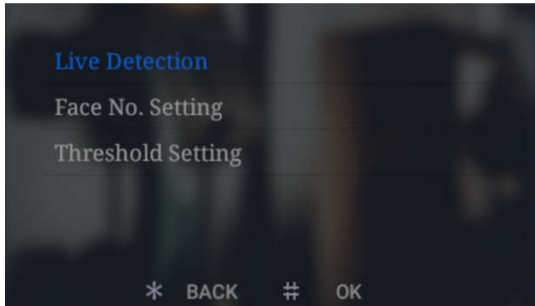

Interface of Face Recognition setting

- **Live Detection**

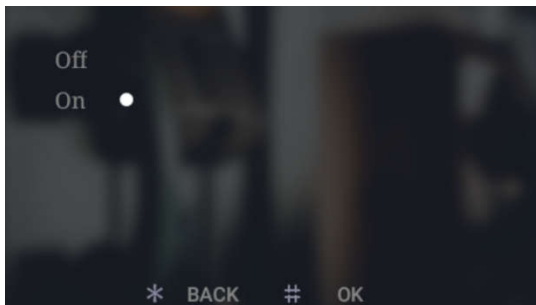

Users can choose whether to open Live Detection or not, press “#” to confirm, “*” to return to Face Recognition Setting interface.

Remark: If Live Detection is opened, resident need to turn their face to left and right side slightly while they are using Face Unlock;

- **Max. Face Storage Setting**

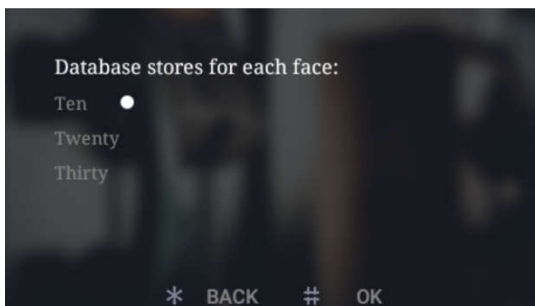

Interface of Max. Face Storage Setting

Users can setup the maximum number of face storage of each apartment, optional: 10, 20, 30.

Press “#” to confirm, “*” to return to Face Recognition Setting interface.

- **Threshold Setting**

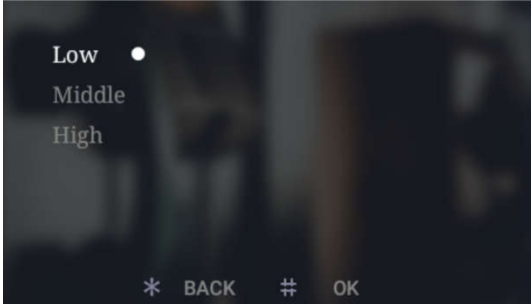

Interface of Threshold Setting

In this interface user can configure the threshold of face recognition(High, Medium, Low), each level corresponds to the accuracy of face matching.

Higher level of threshold comes with higher accuracy of face recognizing. Vice versa.

7.4 Config. Password

To change the configuration password: input the current password, then move to new password box for entering new password. When inputting the new password correctly twice, it will save the modification. Password number limitation: 6 digits.

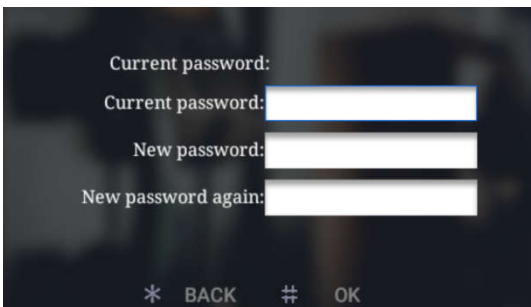

Interface of config. password setting

7.5 Proximity Detection

User can choose to open/close this function, press “#” to confirm and “*” to return Face Recognition interface.

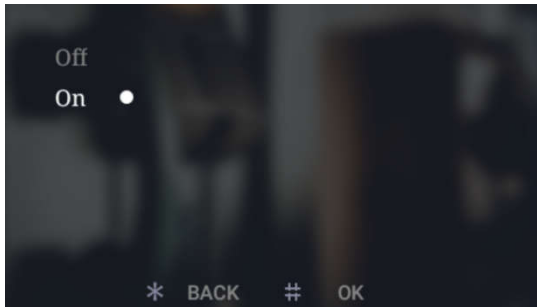

Proximity detection interface

7.6 Community Code Config.

To add the Community Code to the Outdoor Station. After adding successfully, the Community Code will show on the interface.

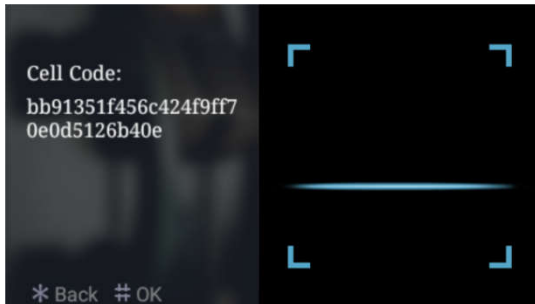

Interface of Community code setting

7.7 Help

The company information interface can be customized(reserved).

In “Version No.” you can find version of the system, IP address, MAC address, etc.

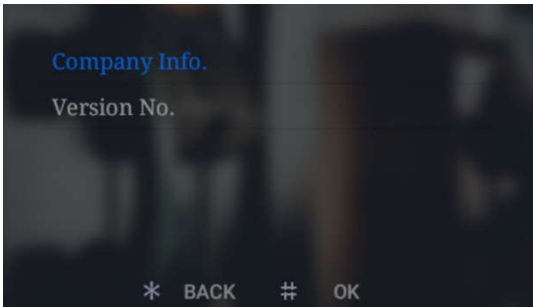

Help interface

7.8 Factory Test

There are various testing programs on factory testing interface, most frequently used are “Reboot System ” and “Reset To Factory”.

When choosing “Reboot system”, choose “confirm” on pop-up box to restart system.

When choosing “Reset To Factory”, choose “confirm” on pop-up box to restore the system as factory setting, using push button mode, all settings (For example the device properties , volume etc.) will be restored as factory setting

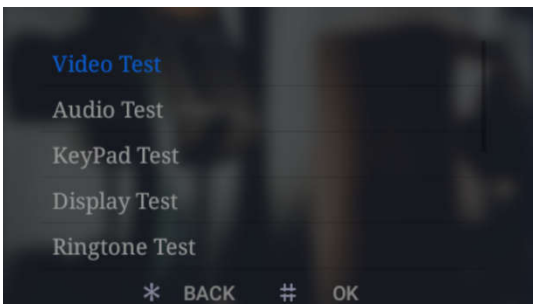

Interface of Factory Test